

Алматы (727)345-47-04
Ангарск (3955)60-70-56
Архангельск (8182)63-90-72
Астрахань (8512)99-46-04
Барнаул (3852)73-04-60
Белгород (4722)40-23-64
Благовещенск (4162)22-76-07
Брянск (4832)59-03-52
Владивосток (423)249-28-31
Владикавказ (8672)28-90-48
Владимир (4922)49-43-18
Волгоград (844)278-03-48
Вологда (8172)26-41-59
Воронеж (473)204-51-73
Екатеринбург (343)384-55-89

Иваново (4932)77-34-06
Ижевск (3412)26-03-58
Иркутск (395)279-98-46
Казань (843)206-01-48
Калининград (4012)72-03-81
Калуга (4842)92-23-67
Кемерово (3842)65-04-62
Киров (8332)68-02-04
Коломна (4966)23-41-49
Кострома (4942)77-07-48
Краснодар (861)203-40-90
Красноярск (391)204-63-61
Курск (4712)77-13-04
Курган (3522)50-90-47
Липецк (4742)52-20-81

Магнитогорск (3519)55-03-13
Москва (495)268-04-70
Мурманск (8152)59-64-93
Набережные Челны (8552)20-53-41
Нижний Новгород (831)429-08-12
Новокузнецк (3843)20-46-81
Ноябрьск (3496)41-32-12
Новосибирск (383)227-86-73
Омск (3812)21-46-40
Орел (4862)44-53-42
Оренбург (3532)37-68-04
Пенза (8412)22-31-16
Петрозаводск (8142)55-98-37
Псков (8112)59-10-37
Пермь (342)205-81-47

Ростов-на-Дону (863)308-18-15
Рязань (4912)46-61-64
Самара (846)206-03-16
Санкт-Петербург (812)309-46-40
Саранск (8342)22-96-24
Саратов (845)249-38-78
Севастополь (8692)22-31-93
Симферополь (3652)67-13-56
Смоленск (4812)29-41-54
Сочи (862)225-72-31
Ставрополь (8652)20-65-13
Сургут (3462)77-98-35
Сыктывкар (8212)25-95-17
Тамбов (4752)50-40-97
Тверь (4822)63-31-35

Тольятти (8482)63-91-07
Томск (3822)98-41-53
Тула (4872)33-79-87
Тюмень (3452)66-21-18
Улан-Удэ (3012)59-97-51
Ульяновск (8422)24-23-59
Уфа (347)229-48-12
Хабаровск (4212)92-98-04
Чебоксары (8352)28-53-07
Челябинск (351)202-03-61
Череповец (8202)49-02-64
Чита (3022)38-34-83
Якутск (4112)23-90-97
Ярославль (4852)69-52-93

Россия +7(495)268-04-70

Казахстан +7(727)345-47-04

Беларусь +(375)257-127-884

Узбекистан +998(71)205-18-59

Киргизия +996(312)96-26-47

<https://ceramtec.nt-rt.ru> || cgc@nt-rt.ru

Аксессуары Ceramaseal



Feedthrough

Description

Accessories is the product classification given by CeramTec for miscellaneous hardware that is used to connect, terminate, install, or isolate Ceramaseal® products.

Multipin Connector

Contacts

- Used to connect conductors for instrumentation, thermocouples and power in high-temperature vacuum systems, inert atmospheres or in air
- Operational to as high as 400° C
- Thermocouple contacts use thermocouple materials to minimize the induced error from dissimilar materials
- Can be used as direct replacement for the contacts in most of our standard plugs

Coaxial

Thermocouple

Plugs

- All coaxial instrumentation and thermocouple plugs can be purchased separately
- All of the standard plugs can be found in the catalog section where they are used
- High voltage (up to 25 kV) and extended temperature range (up to 260° C) plugs are shown here in the Accessories section

Isolator

In-Vacuum Cables

- Voltages up to 2 kV DC
- Current up to 25 Amps
- Suitable for UHV use
- Temperature ratings as high as 650° C
- Variety of terminations
- Can be used with many CeramTec feedthroughs
- Dual cables for instrumentation and thermocouple pairs

Viewport

Pressure

Ceramic Spacers

- Manufactured from high-alumina ceramics
- For use in UHV, inert atmospheres or air
- Can be subjected to the high temperatures associated with bake-out cycles
- Can be used in excess of 800° C, but are limited by thermal expansion differences of conductors

Accessories

Technical Reference



- Will accommodate up to 35 conductors while maintaining separation required to withstand instrumentation voltages

Ceramic Standoffs

- Manufactured from high-vacuum grade non-porous ceramic
- 300 series stainless steel washers and 400 series stainless steel bolts provided
- Can be used at temperatures up to 400° C
- Can be used to support cables, plates or samples at elevated voltages within a vacuum or pressure system
- Voltages to 40 kV in vacuum, 16 kV in air
- Refer to the dielectric strength vs. pressure charts in the Technical Reference section for the value associated with changes in pressure

Vacuum Flanges

- Manufactured to meet industry standards
- Made from 304 stainless steel specially processed to eliminate microscopic leak paths

ConFlat Flange

- Vacuum rating to 10⁻¹⁰ torr or better after repeated cycling from -196° C to 450° C
- Create a reliable seal by compressing a flat copper gasket between the seal surfaces of two compatible flanges.





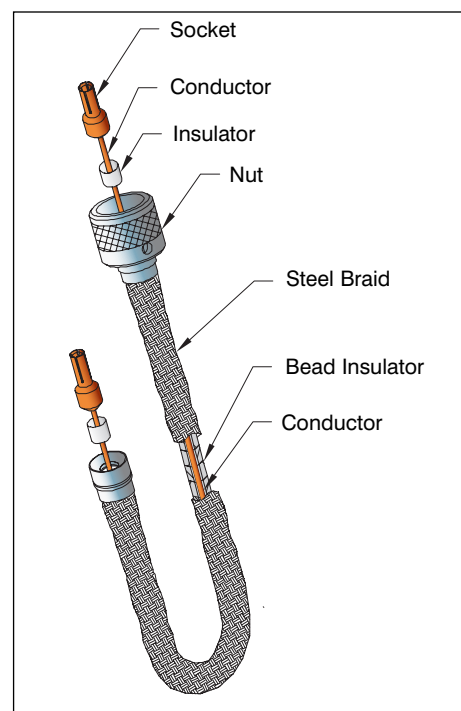

- Can also be used with an o-ring to make the seal

ISO-NW Flange

- Vacuum rating to 10⁻⁹ torr after sustained use to 150° C. Repeated bakeout to 200° C can cause deterioration of o-rings and require periodic replacement.
- Create a vacuum seal by closing an aluminum clamp to compress a Viton o-ring on a centering ring between mating flanges

Typical Cable Construction



Type	Voltage DC	Current	Temperature Rating °C		Material	Sub-section	Section Pages
			Min	Max			
	NA	to 1000 Amps	-269	400	Copper, Copper Alloy, Beryllium Copper, Nickel Alloy, Chromel, Aludel	Contacts	H.1 194-195
	to 12 kV	to 46 Amps	-269	260	See Drawings/Table	Plugs	H.2 196-201
	to 25 kV	to 100 Amps	-70	200	See Drawings/Table	Air Side Cables	H.3 202-205
	to 2 kV	to 25 Amps	-269	650	Kapton® Insulated, Stn. Stl. Braid & Alumina Bead Insulator	In-Vacuum Cables	H.4 206-213
	to 40 kV	NA	-269	800	Steatite, Ceramic – 85% Alumina	Standoffs & Spacers	H.5 214-215
	NA	NA	-269	450	304 Stn. Stl.	Flanges	H.6 216-217

Feedthrough

Multipin Connector

Coaxial

Thermocouple

Isolator

Viewport

Pressure

Accessories

Technical Reference

Feedthrough
Multipin Connector
Coaxial
Thermocouple
Isolator
Viewport
Pressure
Accessories
Technical Reference

Crimp Contacts

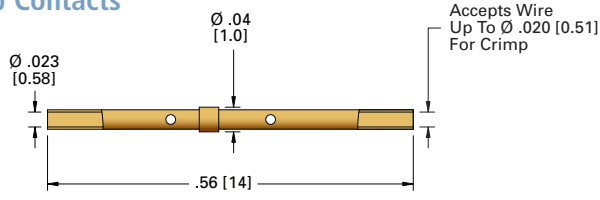

Figure 1

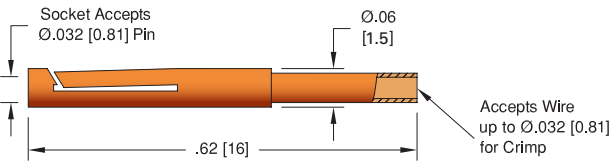

Figure 2

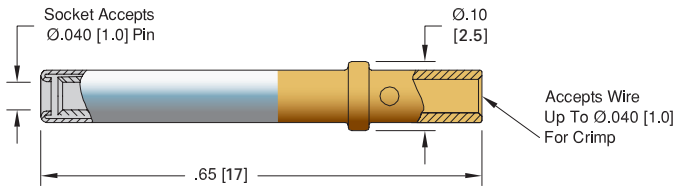

Figure 3

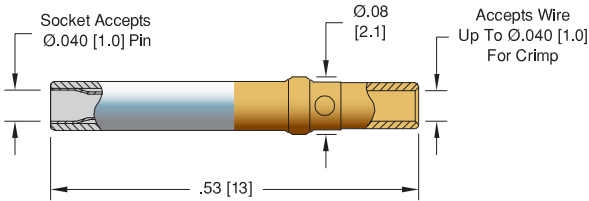

Figure 4

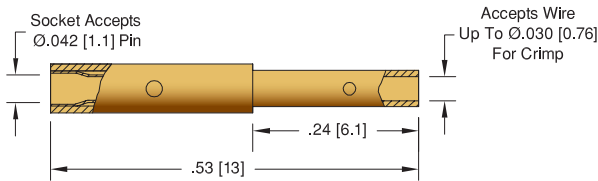

Figure 5

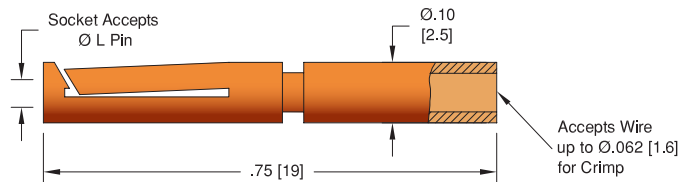

Figure 6

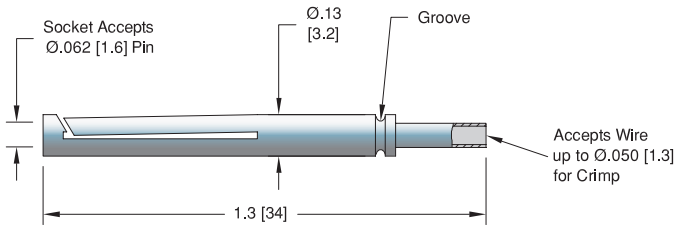

Figure 7

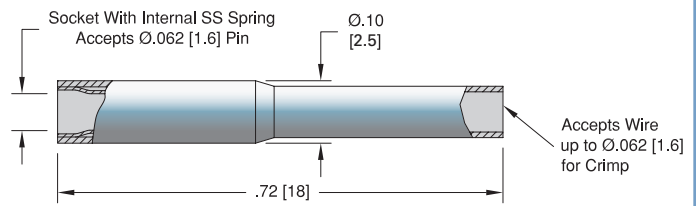

Figure 8

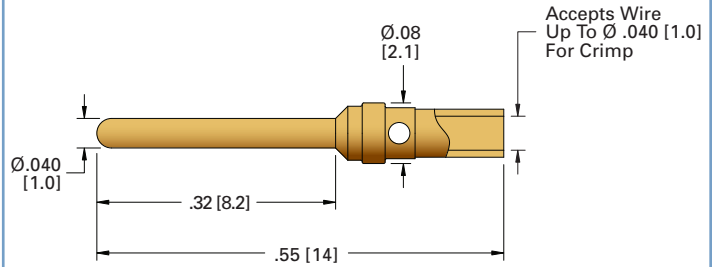

Figure 9

Set Screw Type Contacts

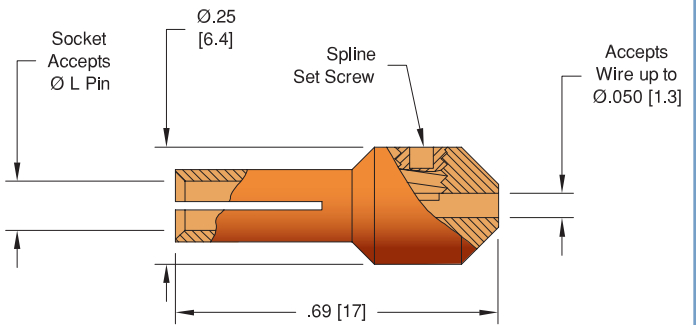

Figure 10

Barrel Type Contacts

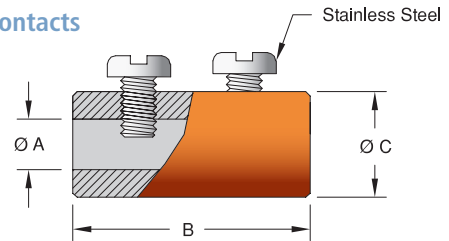

Figure 11

Clamp Type Contacts

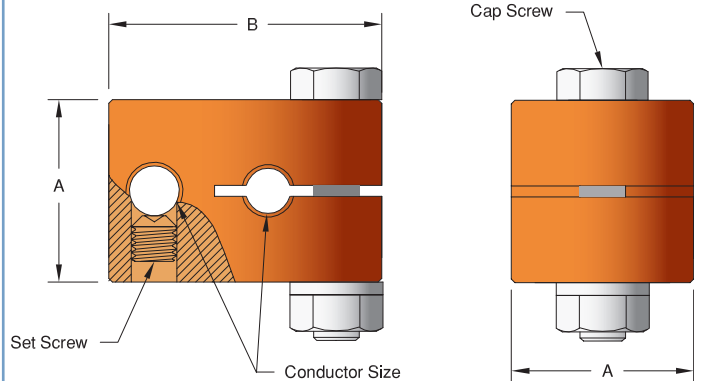

Figure 12



ACCEPTS PIN DIA.	FIGURE	MATERIAL	CURRENT AMPS	TEMPERATURE MIN	TEMPERATURE MAX	GROOVE	GOLD PLATED	QTY/PK	PART NUMBER
.020 [0.51]	1	Beryllium Copper	2	-269	200	-	Yes	5/Pk	21446-02-A
.032 [0.81]	2	Beryllium Copper	16	-269	200	-	No	10/Pk	11288-02-X†
.040 [1.0]	3	Copper Alloy - Gold Flash	15	-200	200	-	No	5/Pk	16167-03-A
.040 [1.0]	4	Copper Alloy - Gold Flash	15	-200	200	-	No	5/Pk	16757-02-A
.042 [1.1]	5	Stainless Steel	2	-269	450	-	Yes	5/Pk	14461-04-A
.050 [1.3]	6	Beryllium Copper	20	-269	200	-	No	10/Pk	11911-02-X
.062 [1.6]	6	Beryllium Copper	20	-269	200	-	No	10/Pk	2044-02-A
.062 [1.6]	7	Chromel	-	-269	350	Yes	No	5/Pk	11259-05-X
.062 [1.6]	7	Alumel	-	-269	350	No	No	5/Pk	11259-06-X
.062 [1.6]	8	Nickel Alloy	10	-269	400	-	No	10/Pk	0821-01-A



MALE PIN DIA.	FIGURE	MATERIAL	CURRENT AMPS	TEMPERATURE MIN	TEMPERATURE MAX	GOLD PLATED	QTY/PK	PART NUMBER
.040 [1.0]	9	Copper Alloy	15	-200	200	Yes	5/Pk	17412-02-A

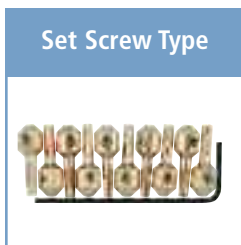

DIAMETER L	FIGURE	MATERIAL	CURRENT AMPS	TEMPERATURE MIN	TEMPERATURE MAX	QTY/PK	PART NUMBER
0.040 [1.0]	10	Beryllium Copper	20	-269	200	10	7429-03-A
0.050 [1.3]	10	Beryllium Copper	25	-269	200	10	7429-02-A
0.094 [2.4]	10	Beryllium Copper	25	-269	200	10	7429-01-A

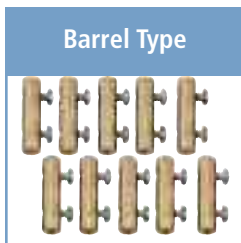

DIAMETER A	FIGURE	MATERIAL	CURRENT AMPS	DIMENSIONS B	DIMENSIONS C	TEMPERATURE MIN	TEMPERATURE MAX	QTY/PK	PART NUMBER
0.040 [1.0]	11	Beryllium Copper	13	0.50 [12.7]	0.13 [3.2]	-269	400	10	7332-01-A
0.050 [1.3]	11	Beryllium Copper	20	0.50 [12.7]	0.19 [4.8]	-269	400	10	7332-02-A
0.062 [1.6]	11	Beryllium Copper	20	0.50 [12.7]	0.19 [4.8]	-269	400	10	7332-03-A
0.094 [2.4]	11	Beryllium Copper	25	0.56 [14.2]	0.25 [6.4]	-269	400	10	7332-04-A
0.125 [3.2]	11	Beryllium Copper	25	0.63 [16.0]	0.25 [6.4]	-269	400	10	7332-05-A
0.154 [3.9]	11	Beryllium Copper	30	0.75 [19.1]	0.33 [8.3]	-269	400	10	7332-07-A
0.250 [6.4]	11	Beryllium Copper	35	1.00 [25.4]	0.50 [12.7]	-269	400	10	7332-06-A

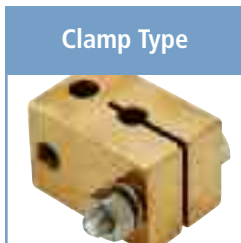

CONDUCTOR SIZE	FIGURE	MATERIAL	CURRENT AMPS	DIMENSIONS A	DIMENSIONS B	TEMPERATURE MIN	TEMPERATURE MAX	PART NUMBER
0.250 [6.4]	12	Copper	350	1.0 [25]	1.5 [38]	-269	400	18740-01-A
0.375 [9.5]	12	Copper	400	1.0 [25]	2.4 [60]	-269	400	18737-01-A
0.500 [12.7]	12	Copper	500	1.0 [25]	2.4 [60]	-269	400	18738-01-A
0.750 [19.1]	12	Copper	1000	1.5 [38]	3.1 [79]	-269	400	18739-01-A



DESCRIPTION	PART NUMBER
Crimp tool for .025" - .075" crimp diameters	2840-05

†Shown in photo.

Feedthrough

Multiple Connector

Coaxial

Thermocouple

Isolator

Viewport

Pressure

Accessories

Technical Reference

Feedthrough
Multipin Connector
Coaxial
Thermocouple
Isolator
Viewport
Pressure
Accessories
Technical Reference

SMB

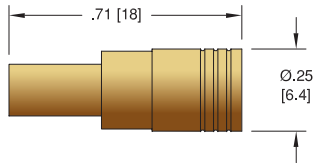

SMA

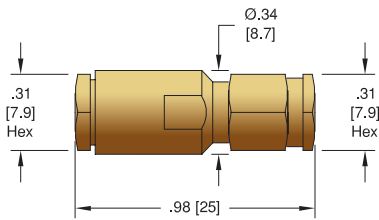

BNC

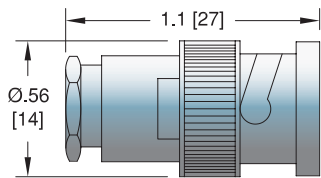

MHV

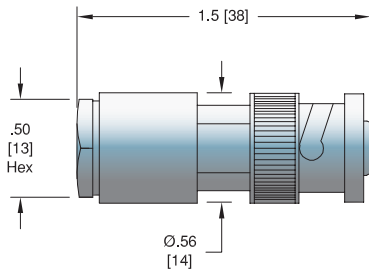

Type N

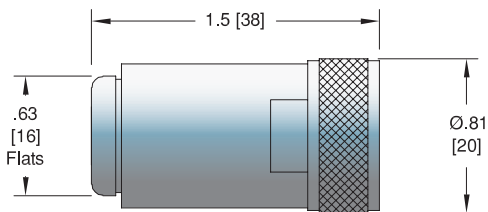

HN

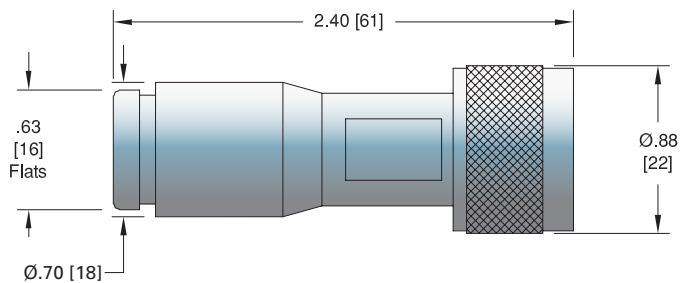

SHV – 5 KV

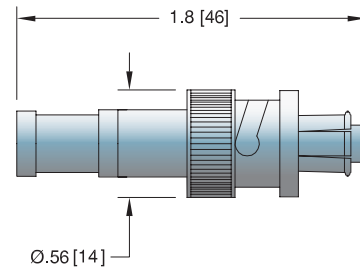

BSHV – 7.5 KV

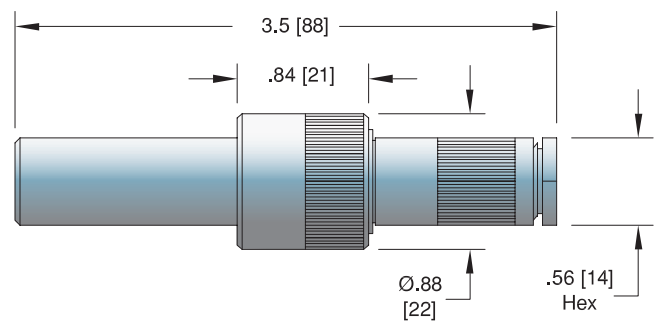

SHV – 10 KV

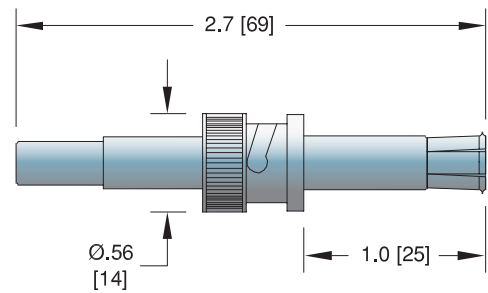

SHV – 20 KV

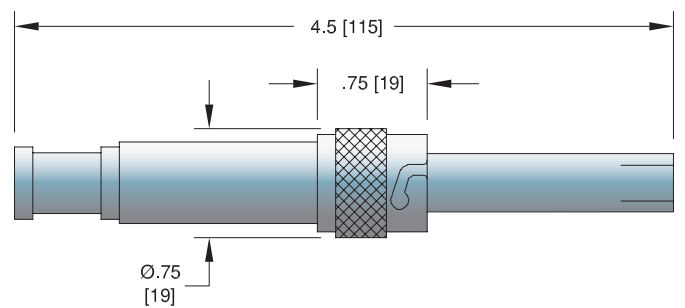

SMB	TYPE	VOLTAGE DC	CONDUCTOR AMPS	TEMPERATURE °C MIN	TEMPERATURE °C MAX	MAGNETIC MATERIALS	PART NUMBER
	SMB Plug: Air Side	375 V	5	-65	165	No	3095-12
SMA	SMA Plug: Air Side	500 V	5	-65	165	No	6524-02
							
BNC & MHV	BNC Plug: Air Side	500 V	5	-65	165	No	7116-02 [†]
	MHV Plug: Air Side	5 kV	10	-65	165	No	7116-01
Type N	Type N Plug: Air Side	1.5 kV	5	-65	165	No	7707-01
							
HN	HN Plug: Air Side	7 kV	10	-55	165	No	6524-05
							
BSHV – 7.5 kV	BSHV Plug: Air Side	7.5 kV	8	-65	400	Yes	7604-01-A
							
SHV	SHV - 5 kV Plug: Air Side	5 kV	10	-65	165	No	8058-01 [†]
	SHV - 10 kV Plug: Air Side	10 kV	10	-65	85	No	8058-02
	SHV - 20 kV Plug: Air Side	20 kV	20	-20	125	No	8208-02

[†]Shown in photo.

Feedthrough

Multiple Connector

Coaxial

Thermocouple

Isolator

Viewport

Pressure

Accessories

Technical Reference

Feedthrough
Multipin Connector
Coaxial
Thermocouple
Isolator
Viewport
Pressure
Accessories
Technical Reference

**MIL-DTL-83513 – Micro D Type
Air Side Plug**

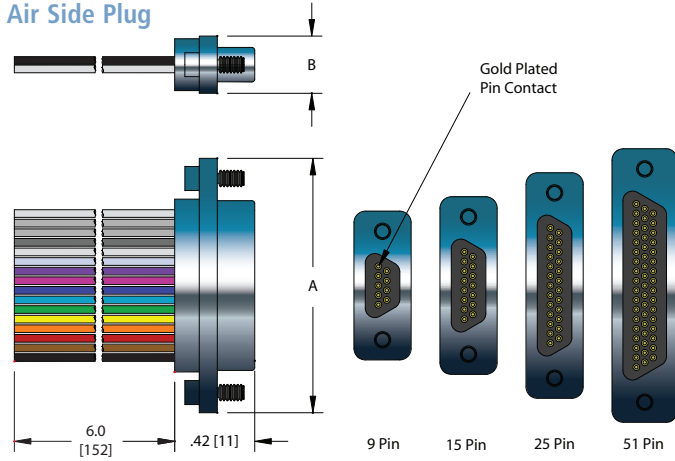

Vacuum Side Plug – PEEK

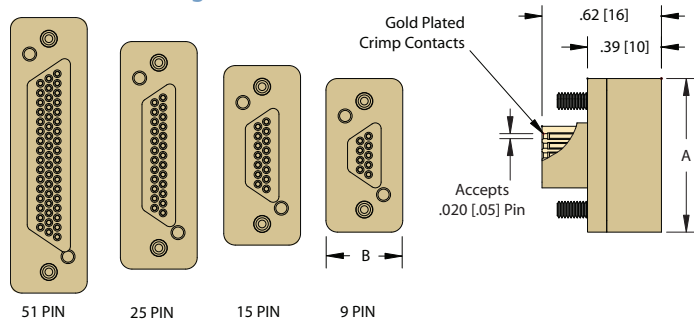

**MIL-C-24308 – Sub D Type
Air Side Plug**

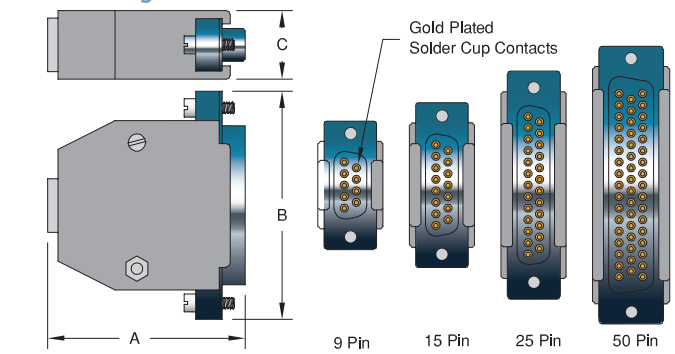

Vacuum Side Plug – PEEK

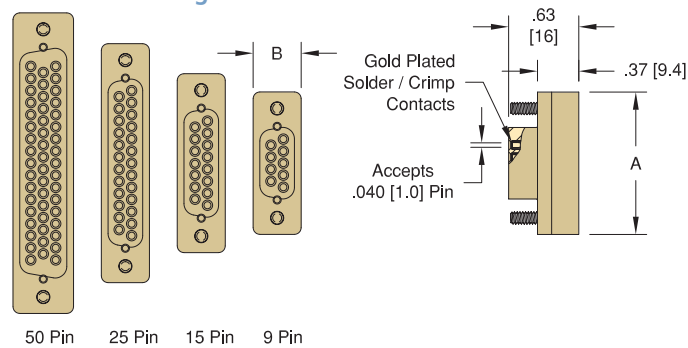

**MIL-C-26482 Type
Air Side Plug**

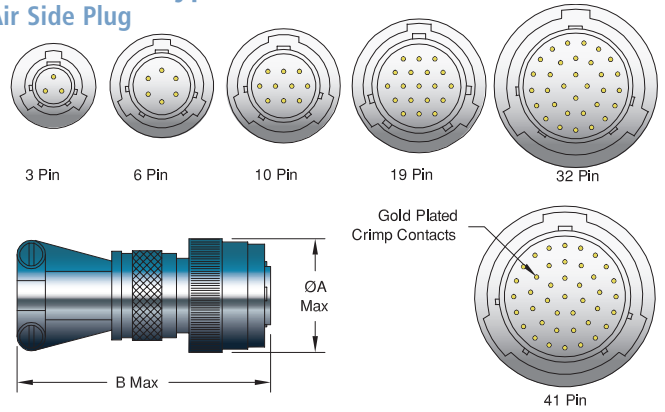

Vacuum Side Plug – PEEK

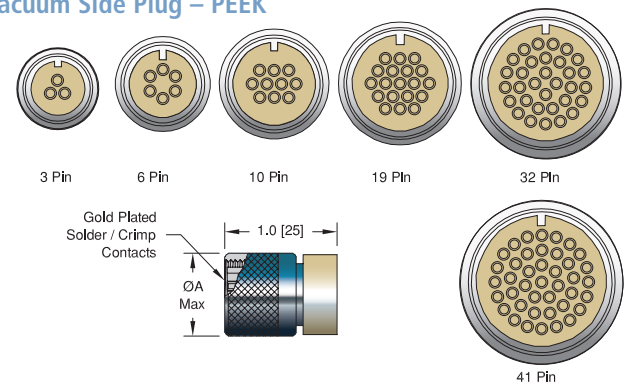

**MIL-C-5015 Type
Air Side Plug**

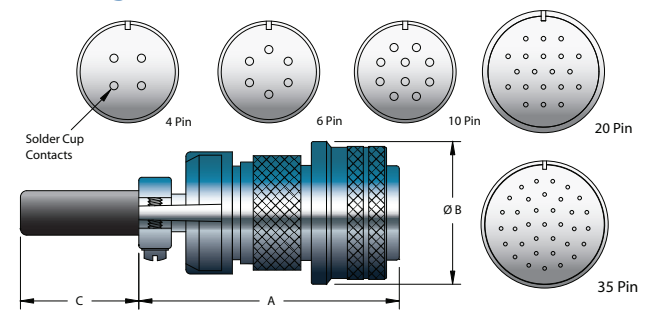

Power-MIL-C-5015 Type

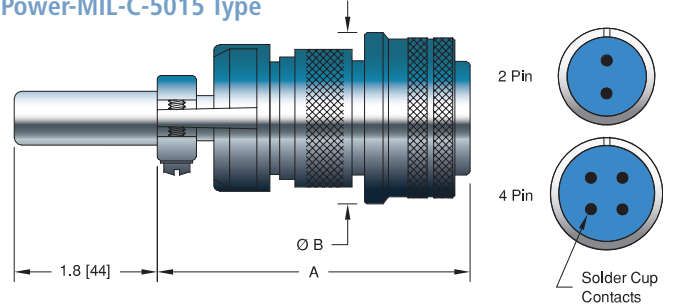

Micro D Type



TYPE	VOLTAGE DC	QTY	CONDUCTOR AMPS	MATERIAL	DIMENSIONS A B		TEMPERATURE °C MIN MAX		MAGNETIC MATERIALS	PART NUMBER
Air Side	500 V	9	3	Copper Alloy	0.775 [20]	0.298 [8]	-55	125	No	21585-01-A
Air Side	500 V	15	3	Copper Alloy	0.925 [23]	0.298 [8]	-55	125	No	21586-01-A
Air Side	500 V	25	3	Copper Alloy	1.175 [30]	0.298 [8]	-55	125	No	21587-01-A†
Air Side	500 V	51	3	Copper Alloy	1.425 [36]	0.341 [9]	-55	125	No	21589-01-A
Vacuum Side	500 V	9	2	Beryllium Copper	0.790 [20]	0.390 [10]	-269	200	No	21573-01-A
Vacuum Side	500 V	15	2	Beryllium Copper	0.935 [24]	0.390 [10]	-269	200	No	21574-01-A
Vacuum Side	500 V	25	2	Beryllium Copper	1.185 [30]	0.390 [10]	-269	200	No	21575-01-A
Vacuum Side	500 V	51	2	Beryllium Copper	1.135 [36]	0.390 [10]	-269	200	No	21577-01-A

Sub D Type



TYPE	VOLTAGE DC	QTY	CONTACTS AMPS	MATERIAL	DIMENSIONS A B C			TEMPERATURE °C MIN MAX		MAGNETIC MATERIALS	PART NUMBER
Air Side	500 V	9	5	Copper Alloy	1.7 [43]	1.2 [31]	0.6 [15]	-55	105	Yes	18076-01-A
Air Side	500 V	15	5	Copper Alloy	1.6 [41]	1.6 [41]	0.6 [15]	-55	105	Yes	18076-02-A
Air Side	500 V	25	5	Copper Alloy	1.9 [48]	2.2 [56]	0.6 [15]	-55	105	Yes	18076-03-A†
Air Side	500 V	50	5	Copper Alloy	2.0 [51]	2.6 [66]	0.7 [18]	-55	105	Yes	18076-04-A
Vacuum Side-Female	500 V	9	5	Copper Alloy	1.3 [33]	0.4 [11]	-	-200	200	No	16810-01-A
Vacuum Side-Female	500 V	15	5	Copper Alloy	1.6 [40]	0.4 [11]	-	-200	200	No	16811-01-A
Vacuum Side-Female	500 V	25	5	Copper Alloy	2.2 [55]	0.4 [11]	-	-200	200	No	16812-01-A†
Vacuum Side-Female	500 V	50	5	Copper Alloy	2.7 [69]	0.5 [14]	-	-200	200	No	16814-01-A
Vacuum Side-Male	500 V	9	5	Copper Alloy	1.3 [33]	0.4 [11]	-	-200	200	No	19827-01-A
Vacuum Side-Male	500 V	15	5	Copper Alloy	1.6 [40]	0.4 [11]	-	-200	200	No	19828-01-A
Vacuum Side-Male	500 V	25	5	Copper Alloy	2.2 [55]	0.4 [11]	-	-200	200	No	17411-01-A
Vacuum Side-Male	500 V	50	5	Copper Alloy	2.7 [69]	0.5 [14]	-	-200	200	No	19829-01-A

MIL-C-26482 Type



TYPE	VOLTAGE DC	QTY	CONTACTS AMPS	MATERIAL	DIMENSIONS A B		TEMPERATURE °C MIN MAX		MAGNETIC MATERIALS	PART NUMBER
Air Side	1 kV	3	1	Copper Alloy	0.8 [20]	1.9 [48]	-55	200	No	16060-01-A†
Air Side	1 kV	6	1	Copper Alloy	1.0 [25]	1.9 [48]	-55	200	No	16060-02-A
Air Side	1 kV	10	1	Copper Alloy	1.0 [25]	1.9 [48]	-55	200	No	16060-03-A
Air Side	1 kV	19	1	Copper Alloy	1.2 [31]	1.9 [48]	-55	200	No	16060-04-A
Air Side	1 kV	32	1	Copper Alloy	1.4 [36]	2.1 [53]	-55	200	No	16060-05-A
Air Side	1 kV	41	1	Copper Alloy	1.5 [38]	2.3 [58]	-55	200	No	16060-06-A
Vacuum Side	1 kV	3	5	Copper Alloy	0.8 [20]	-	-200	200	No	16026-02-A†
Vacuum Side	1 kV	6	5	Copper Alloy	0.9 [22]	-	-200	200	No	16027-02-A
Vacuum Side	1 kV	10	5	Copper Alloy	1.0 [25]	-	-200	200	No	16028-02-A
Vacuum Side	1 kV	19	5	Copper Alloy	1.1 [28]	-	-200	200	No	16029-02-A
Vacuum Side	1 kV	32	5	Copper Alloy	1.4 [34]	-	-200	200	No	16030-02-A
Vacuum Side	1 kV	41	5	Copper Alloy	1.5 [37]	-	-200	200	No	16031-02-A

MIL-C-5015 Type



TYPE	VOLTAGE DC	QTY	CONTACTS AMPS	MATERIAL	DIMENSIONS A B C			TEMPERATURE °C MIN MAX		MAGNETIC MATERIALS	PART NUMBER
Air Side	700 V	4	13	Copper Alloy	2.6 [65]	1.4 [36]	1.8 [44]	-55	125	No	15910-01-A
Air Side	700 V	6	13	Copper Alloy	2.6 [65]	1.4 [36]	1.8 [44]	-55	125	No	15911-01-A
Air Side	700 V	10	13	Copper Alloy	2.6 [65]	1.4 [36]	1.8 [44]	-55	125	No	15912-01-A
Air Side	700 V	20	13	Copper Alloy	2.9 [74]	1.9 [49]	1.4 [36]	-55	125	No	15913-01-A†
Air Side	700 V	35	13	Copper Alloy	3.0 [77]	2.5 [62]	1.2 [30]	-55	125	No	15914-01-A
Air Side: Hi-Temp PEEK	700 V	4	4.8	Alumel	2.6 [65]	1.4 [36]	1.8 [44]	-55	260	Yes	15910-32-A
Air Side: Hi-Temp PEEK	700 V	6	4.8	Alumel	2.6 [65]	1.4 [36]	1.8 [44]	-55	260	Yes	15911-32-A
Air Side: Hi-Temp PEEK	700 V	10	4.8	Alumel	2.6 [65]	1.4 [36]	1.8 [44]	-55	260	Yes	15912-32-A
Power: .094 Contacts	700 V	2	23	Copper Alloy	2.5 [63]	1.2 [32]	-	-55	125	No	18600-01-A
Power: .094 Contacts	700 V	4	23	Copper Alloy	2.5 [63]	1.4 [36]	-	-55	125	No	18600-02-A
Power: .142 Contacts	700 V	2	46	Copper Alloy	2.6 [65]	1.6 [40]	-	-55	125	No	18601-01-A
Power: .142 Contacts	700 V	4	46	Copper Alloy	2.6 [65]	1.6 [40]	-	-55	125	No	18601-02-A

Note that contacts are included with all plugs. †Shown in photo.

Feedthrough

Multipin Connector

Coaxial

Thermocouple

Isolator

Viewport

Pressure

Accessories

Technical Reference

Feedthrough

Multipin Connector

Coaxial

Thermocouple

Isolator

Viewport

Pressure

Accessories

Technical Reference

High Voltage 2 & 4 Contacts

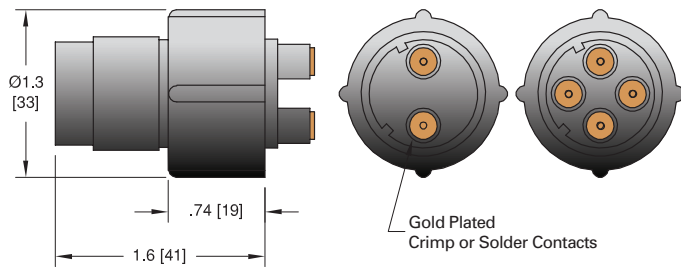

7 Contacts

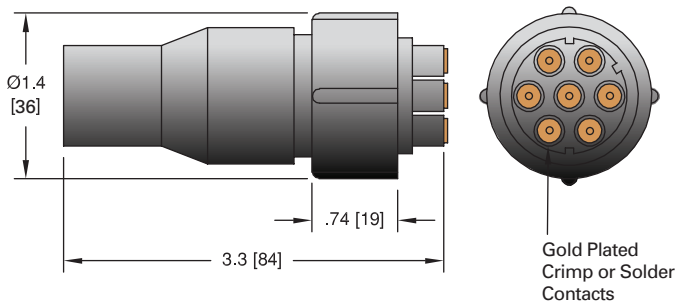

Thermocouple Spade Type

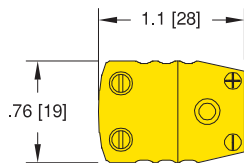

Thermocouple MIL-C-5015 Type

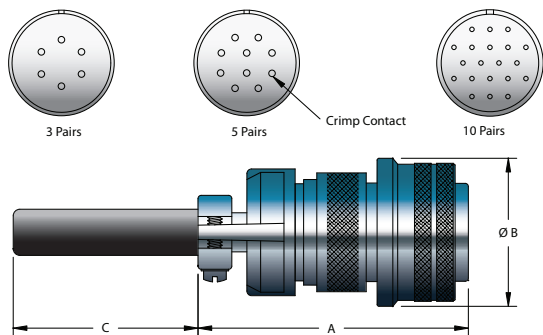

High Voltage



TYPE	VOLTAGE DC	QTY	CONTACTS AMPS	MATERIAL	TEMPERATURE °C MIN	TEMPERATURE °C MAX	MAGNETIC MATERIALS	PART NUMBER
Air Side	12 kV	2	13	Copper Alloy	-15	85	No	2871-02-A†
Air Side	12 kV	4	13	Copper Alloy	-15	85	No	2871-03-A
Air Side	12 kV	7	13	Copper Alloy	-15	85	No	2871-01-A

Thermocouple Spade Type



ANSI TYPE	THERMOCOUPLE MATERIALS	TYPE	PLUG MATERIALS	TEMPERATURE °C MIN	TEMPERATURE °C MAX	COLOR CODE	MAGNETIC MATERIALS	PART NUMBER
K	Chromel/Alumel	Standard	Glass Filled Nylon	-29	218	Yellow	Yes	08151-01†
K	Chromel/Alumel	High Temp	Ceramic	-73	650	Yellow	Yes	08151-09
C	Tungsten - Rhenium	Standard	Glass Filled Nylon	-29	218	Red	Yes	08151-04
C	Tungsten - Rhenium	High Temp	Ceramic	-73	250	Red	Yes	08151-07

Thermocouple MIL-C-5015 Type



ANSI TYPE	T/C PAIRS	THERMOCOUPLE MATERIALS	DIMENSIONS			TEMPERATURE °C		MAGNETIC MATERIALS	PART NUMBER
			A	B	C	MIN	MAX		
K	3	Chromel/Alumel	2.6 [65]	1.4 [36]	1.8 [44]	-55	125	Yes	15911-02-A
K	5	Chromel/Alumel	2.6 [65]	1.4 [36]	1.8 [44]	-55	125	Yes	15912-02-A
K	10	Chromel/Alumel	2.9 [74]	1.9 [49]	1.4 [36]	-55	125	Yes	15913-02-A†

Note that contacts are included with all plugs. †Shown in photo.

Thermocouple Extended Range MIL-C-5015 Type



TYPE	VOLTAGE DC	QTY	CONTACTS AMPS	MATERIAL	TEMPERATURE °C MIN	TEMPERATURE °C MAX	MAGNETIC MATERIALS	PART NUMBER
Extended Range - Teflon	700 V	4	4.8	Copper Alloy	-65	200	No	15910-11-A
Extended Range - Teflon	700 V	6	4.8	Copper Alloy	-65	200	No	15911-11-A
Extended Range - Teflon	700 V	10	4.8	Copper Alloy	-65	200	No	15912-11-A
Extended Range - Teflon	700 V	2 pr.	-	Chromel/Alumel	-65	200	Yes	15910-12-A
Extended Range - Teflon	700 V	3 pr.	-	Chromel/Alumel	-65	200	Yes	15911-12-A
Extended Range - Teflon	700 V	5 pr.	-	Chromel/Alumel	-65	200	Yes	15912-12-A
Extended Range - PEEK	700 V	2 pr.	-	Chromel/Alumel	-55	260	Yes	15910-31-A
Extended Range - PEEK	700 V	3 pr.	-	Chromel/Alumel	-55	260	Yes	15911-31-A
Extended Range - PEEK	700 V	5 pr.	-	Chromel/Alumel	-55	260	Yes	15912-31-A

Feedthrough

Multiple Connector

Coaxial

Thermocouple

Isolator

Viewport

Pressure

Accessories

Technical Reference

Feedthrough
Multipin Connector
Coaxial
Thermocouple
Isolator
Viewport
Pressure
Accessories
Technical Reference

Microdot

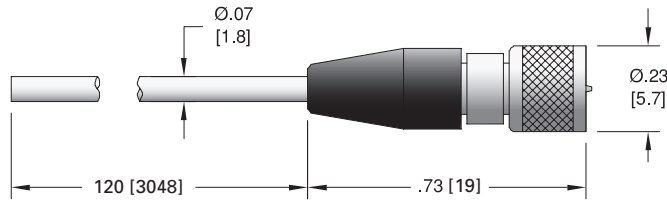

SMB

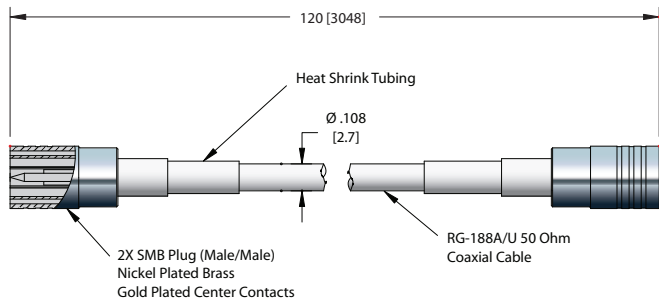

SMA

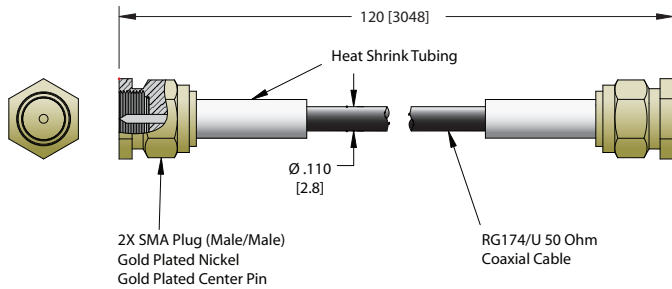

BNC

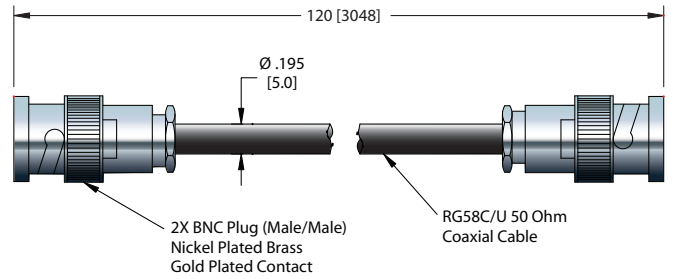

MHV

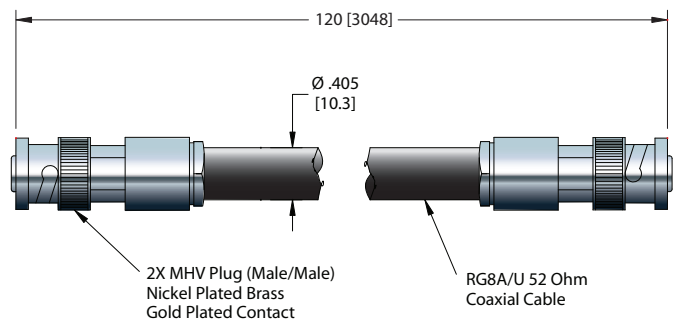

Type N

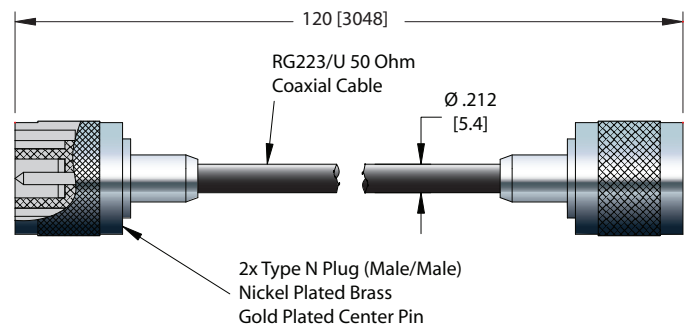

SHV - 5 KV

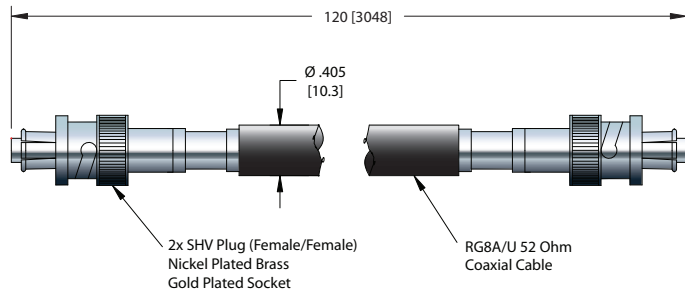

	TYPE	CABLE	CABLE LENGTH	VOLTAGE DC	CONDUCTOR AMPS	TEMPERATURE °C MIN	TEMPERATURE °C MAX	PART NUMBER
<p>Single Ended Microdot</p> 	Microdot	RG196A/U	10'	1 kV	2	-65	125	14544-01-A
<p>Double Ended SMB</p> 	50 Ohm SMB	RG188A/U	10'	500 V	2	-70	200	21618-01-A
<p>Double Ended SMA</p> 	50 Ohm SMA	RG174/U	10'	500 V	5	-45	75	21617-01-A
<p>Double Ended BNC</p> 	50 Ohm BNC	RG58C/U	10'	500 V	5	-40	85	18921-01-A
<p>Double Ended MHV</p> 	52 Ohm MHV	RG8A/U	10'	5 kV	10	-55	85	18921-02-A
<p>Double Ended Type N</p> 	50 Ohm Type N	RG223/U	10'	1.5 kV	5	-40	60	21619-01-A
<p>Double Ended SHV – 5 KV</p> 	52 Ohm SHV	RG8A/U	10'	5 kV	10	-55	85	18921-03-A

Feedthrough

Multiple Connector

Coaxial

Thermocouple

Isolator

Viewport

Pressure

Accessories

Technical Reference

Feedthrough

Multipin Connector

Coaxial

Thermocouple

Isolator

Viewport

Pressure

Accessories

Technical Reference

Micro HV

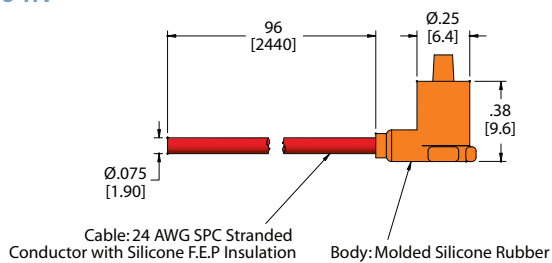

Mini HV

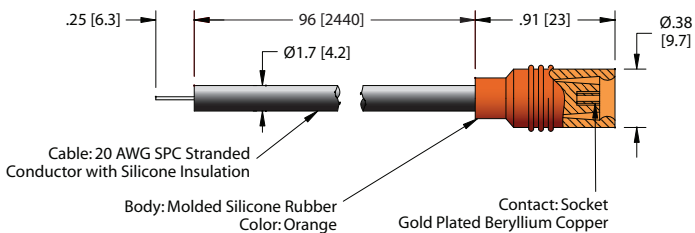

10 kV Power Plug

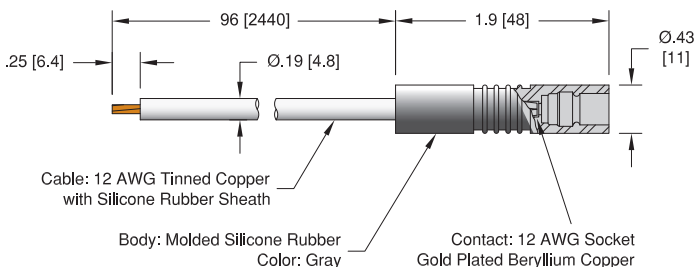

20 KV Power Plug

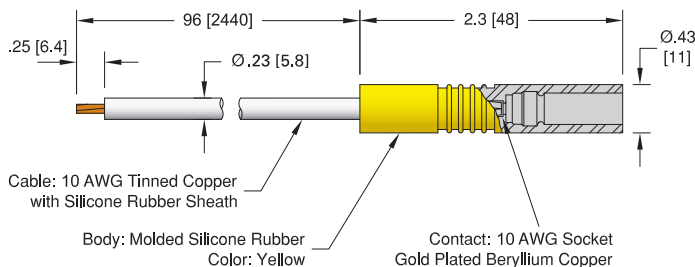

.154 Power Plug

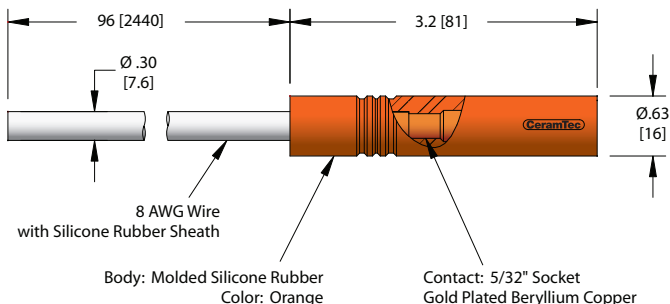

.250 Power Plug

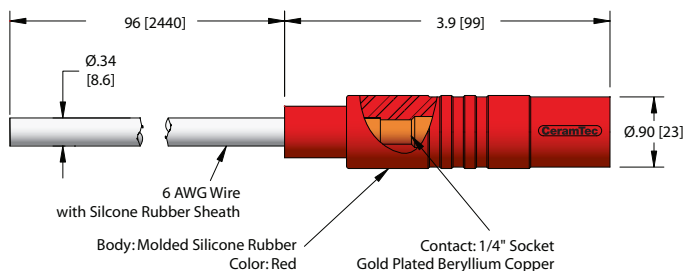

High Voltage – 40 KV

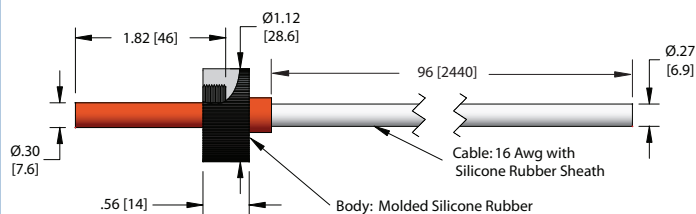

High Voltage – 50 KV

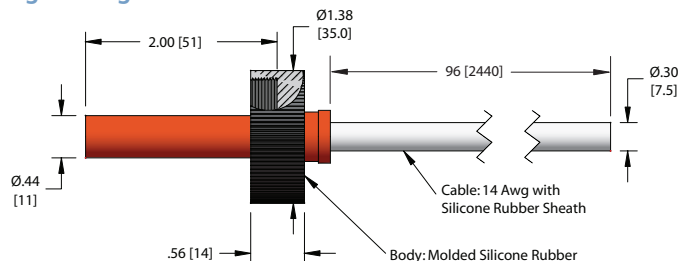



TYPE	CABLE TYPE	LENGTH	VOLTAGE DC	CONDUCTOR AMPS	TEMPERATURE °C MIN	TEMPERATURE °C MAX	PART NUMBER
Micro HV	24 AWG	8'	10 kV	3	-55°C	125°C	21039-01-A
Mini HV	20 AWG	8'	15 kV	7.5	-55°C	125°C	21119-01-A
10 kV Power Plug	12 AWG	8'	10 kV	30	-55°C	125°C	14418-02-A
20 kV Power Plug	10 AWG	8'	20 kV	55	-55°C	125°C	14419-02-A
.154 Power Plug	8 AWG	8'	10 kV	75	-55°C	125°C	21094-01-A
.250 Power Plug	6 AWG	8'	25 kV	100	-55°C	125°C	20956-02-A
40 kV Air Side	16 AWG	8'	40 kV	10	-55°C	125°C	21034-01-A
50 kV Air Side	14 AWG	8'	50 kV	10	-55°C	125°C	21112-01-A

Feedthrough

Multi-pin Connector

Coaxial

Thermocouple

Isolator

Viewport

Pressure

Accessories

Technical Reference

Feedthrough
Multipin Connector
Coaxial
Thermocouple
Isolator
Viewport
Pressure
Accessories
Technical Reference

**Duplex Shielded
.030 [0.76] Dia. Conductor**

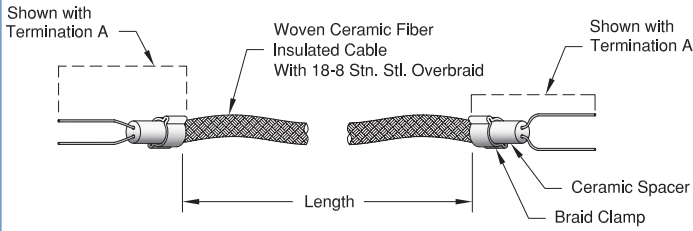

Termination A – Bare Conductor

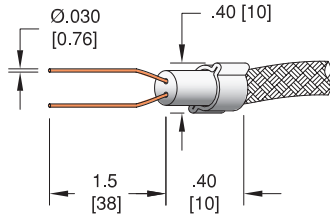

Termination B – Thermocouple Bead

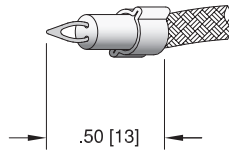

Termination C – BeCu Contacts

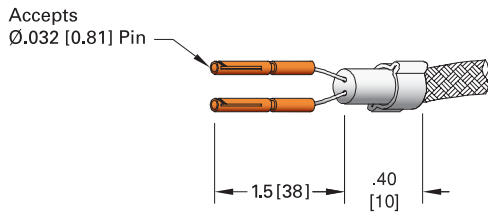

Termination D – Nickel Contacts

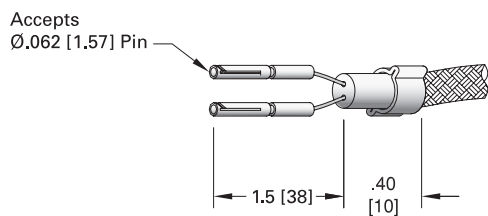

Termination E – Chromel/Alumel Contacts

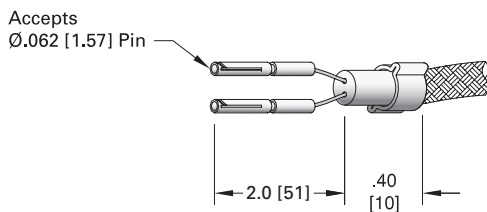

**Cable Components
Beads**

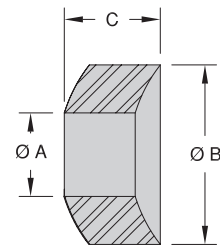

Conductor

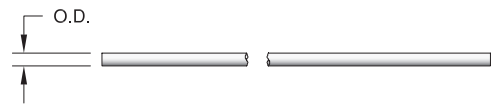

Braid

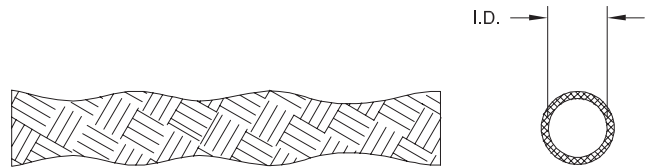

Note: For length greater than 36 inches, call for pricing and availability.

Duplex Shielded Two Conductors

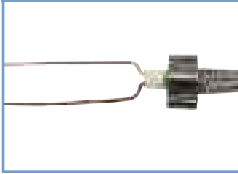

VOLTAGE DC	TERMINATION			CONDUCTOR AMPS	CONDUCTOR MATERIAL	CONTACT MATERIAL	TEMPERATURE °C		MAGNETIC MATERIALS	PART NUMBER
	END 1	END 2	LENGTH				MIN	MAX		
500 V	A	A	12"	15	Copper/Copper	-	-269	650	No	18682-12-AA
500 V	A	C	12"	15	Copper/Copper	BeCu	-269	200	No	18682-12-AC
500 V	A	D	12"	15	Copper/Copper	Nickel Alloy	-200	400	Yes	18682-12-AD
500 V	C	C	12"	15	Copper/Copper	BeCu	-269	200	No	18682-12-CC
500 V	D	D	12"	15	Copper/Copper	Nickel Alloy	-200	400	Yes	18682-12-DD
500 V	A	A	24"	15	Copper/Copper	-	-269	650	No	18682-24-AA
500 V	A	C	24"	15	Copper/Copper	BeCu	-269	200	No	18682-24-AC
500 V	A	D	24"	15	Copper/Copper	Nickel Alloy	-200	400	Yes	18682-24-AD
500 V	C	C	24"	15	Copper/Copper	BeCu	-269	200	No	18682-24-CC
500 V	D	D	24"	15	Copper/Copper	Nickel Alloy	-200	400	Yes	18682-24-DD
500 V	A	A	36"	15	Copper/Copper	-	-269	650	No	18682-36-AA
500 V	A	C	36"	15	Copper/Copper	BeCu	-269	200	No	18682-36-AC
500 V	A	D	36"	15	Copper/Copper	Nickel Alloy	-200	400	Yes	18682-36-AD
500 V	C	C	36"	15	Copper/Copper	BeCu	-269	200	No	18682-36-CC
500 V	D	D	36"	15	Copper/Copper	Nickel Alloy	-200	400	Yes	18682-36-DD

Duplex Shielded Thermocouple

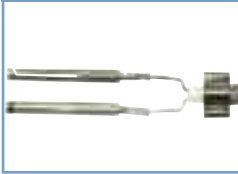

VOLTAGE DC	TERMINATION			ANSI TYPE	CONDUCTOR/CONTACT MATERIAL	TEMPERATURE °C		MAGNETIC MATERIALS	PART NUMBER
	END 1	END 2	LENGTH			MIN	MAX		
500 V	A	A	12"	K	Chromel/Alumel	-269	650	Yes	18684-12-AA
500 V	A	B	12"	K	Chromel/Alumel	-200	650	Yes	18684-12-AB
500 V	A	E	12"	K	Chromel/Alumel	-269	350	Yes	18684-12-AE
500 V	A	A	24"	K	Chromel/Alumel	-269	650	Yes	18684-24-AA
500 V	A	B	24"	K	Chromel/Alumel	-200	650	Yes	18684-24-AB
500 V	A	E	24"	K	Chromel/Alumel	-269	350	Yes	18684-24-AE
500 V	A	A	36"	K	Chromel/Alumel	-269	650	Yes	18684-36-AA
500 V	A	B	36"	K	Chromel/Alumel	-200	650	Yes	18684-36-AB
500 V	A	E	36"	K	Chromel/Alumel	-269	350	Yes	18684-36-AE

Beads



MATERIAL	DIMENSIONS			BEADS PER FOOT	TEMPERATURE °C		PART NUMBER
	A	B	C		MIN	MAX	
96% Min Alumina	0.056 [1.42]	0.110 [2.79]	0.110 [2.79]	120	-269	800	07424-01
Steatite Grade L3	0.068 [1.73]	0.170 [4.32]	0.170 [4.32]	84	-269	600	07424-03
Steatite Grade L3	0.087 [2.21]	0.180 [4.57]	0.100 [2.54]	120	-269	600	07424-06
Steatite Grade L3	0.092 [2.34]	0.200 [5.08]	0.200 [5.08]	72	-269	600	07424-02

Conductor



DIAMETER	CONDUCTOR MATERIAL	AMPS	PART NUMBER
0.032 [0.81]	Copper	16	18745-01
0.036 [0.91]	Zirconium Copper	17	18745-02
0.050 [1.3]	Nickel	8.2	18745-03
0.050 [1.3]	Zirconium Copper	30	18745-04
0.050 [1.3]	Copper	27	18745-05

Braid



BRAID INSIDE DIAMETER	PART NUMBER
0.125 [3.18]	18746-01
0.250 [6.35]	18746-02

Feedthrough

Multipin Connector

Coaxial

Thermocouple

Isolator

Viewport

Pressure

Accessories

Technical Reference

Feedthrough

Multipin Connector

Coaxial

Thermocouple

Isolator

Viewport

Pressure

Accessories

Technical Reference

**Coaxial: 1/8" Diameter
.036 [0.91] Dia. Conductor**

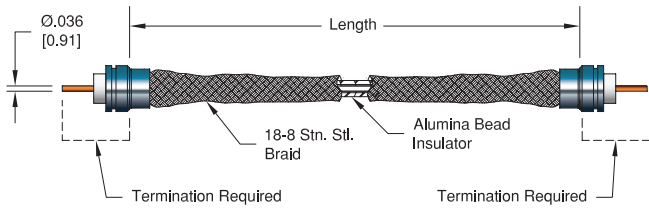

Termination A – Coaxial

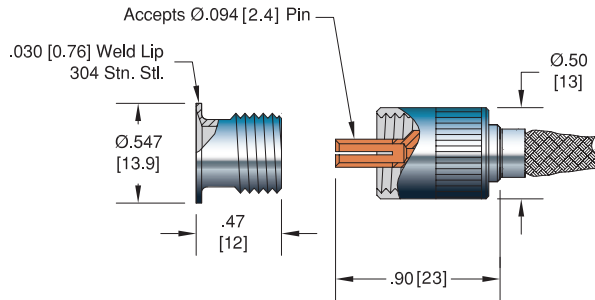

Termination B – Contact

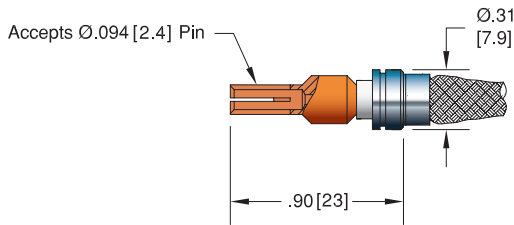

Termination C – In-Line

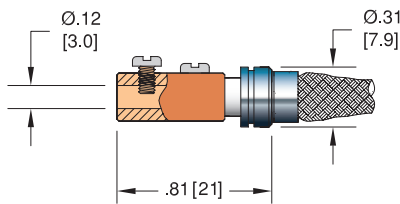

Termination – BNC & MHV

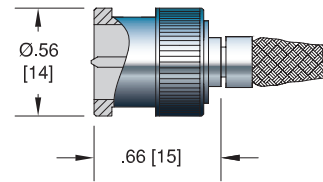

1/8" Cable Splice

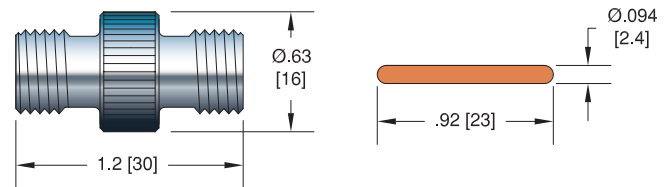

Microdot

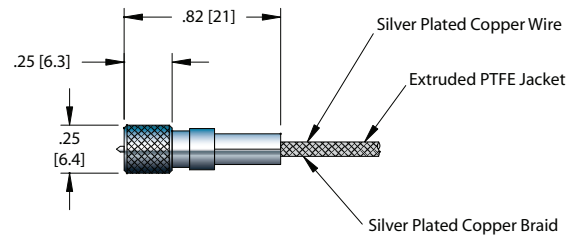

Note: For length greater than 36 inches, call for pricing and availability.

Coaxial Cables
1/8" Diameter

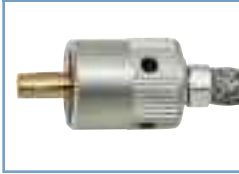

VOLTAGE DC	TERMINATION			CONDUCTOR AMPS	CONDUCTOR MATERIAL	TEMPERATURE°C		MAGNETIC MATERIALS	PART NUMBER
	END 1	END 2	LENGTH			MIN	MAX		
1.5 V	A	A	12"	15	Zirconium Copper	-269	200	No	18680-12-AA
1.5 V	A	B	12"	15	Zirconium Copper	-269	200	No	18680-12-AB
1.5 V	A	C	12"	15	Zirconium Copper	-269	200	No	18680-12-AC
1.5 V	A	BNC	12"	15	Zirconium Copper	-269	200	No	18680-12-AE
1.5 V	A	MHV	12"	15	Zirconium Copper	-269	200	No	18680-12-AF
1.5 V	B	B	12"	15	Zirconium Copper	-269	200	No	18680-12-BB
1.5 V	B	C	12"	15	Zirconium Copper	-269	200	No	18680-12-BC
1.5 V	C	C	12"	15	Zirconium Copper	-269	350	No	18680-12-CC
1.5 V	A	A	24"	15	Zirconium Copper	-269	200	No	18680-24-AA
1.5 V	A	B	24"	15	Zirconium Copper	-269	200	No	18680-24-AB
1.5 V	A	C	24"	15	Zirconium Copper	-269	200	No	18680-24-AC
1.5 V	A	BNC	24"	15	Zirconium Copper	-269	200	No	18680-24-AE
1.5 V	A	MHV	24"	15	Zirconium Copper	-269	200	No	18680-24-AF
1.5 V	B	B	24"	15	Zirconium Copper	-269	400	No	18680-24-BB
1.5 V	B	C	24"	15	Zirconium Copper	-269	400	No	18680-24-BC
1.5 V	C	C	24"	15	Zirconium Copper	-269	350	No	18680-24-CC
1.5 V	A	A	36"	15	Zirconium Copper	-269	200	No	18680-36-AA
1.5 V	A	B	36"	15	Zirconium Copper	-269	200	No	18680-36-AB
1.5 V	A	C	36"	15	Zirconium Copper	-269	200	No	18680-36-AC
1.5 V	A	BNC	36"	15	Zirconium Copper	-269	200	No	18680-36-AE
1.5 V	A	MHV	36"	15	Zirconium Copper	-269	200	No	18680-36-AF
1.5 V	B	B	36"	15	Zirconium Copper	-269	400	No	18680-36-BB
1.5 V	B	C	36"	15	Zirconium Copper	-269	400	No	18680-36-BC
1.5 V	C	C	36"	15	Zirconium Copper	-269	350	No	18680-36-CC

Cable Splice



SIZE	VOLTAGE DC	CONDUCTOR AMPS	CONDUCTOR MATERIAL	TEMPERATURE°C MIN	TEMPERATURE°C MAX	MAGNETIC MATERIALS	PART NUMBER
1/8"	1.5 kV	15	Copper	-269	400	No	18727-01-A

Microdot Cable Assembly



VOLTAGE DC	TERMINATION			CONDUCTOR AMPS	CONDUCTOR MATERIAL	TEMPERATURE°C		MAGNETIC MATERIALS	PART NUMBER
	END 1	END 2	LENGTH			MIN	MAX		
500 V	Microdot	Microdot	12"	2	Silver Plated Copper	-65	125	No	15767-12-A
500 V	Microdot	Microdot	24"	2	Silver Plated Copper	-65	125	No	15767-24-A
500 V	Microdot	Microdot	36"	2	Silver Plated Copper	-65	125	No	15767-36-A†

†Shown in photo.

Feedthrough

Multiple Connector

Coaxial

Thermocouple

Isolator

Viewport

Pressure

Accessories

Technical Reference

Feedthrough
Multipin Connector
Coaxial
Thermocouple
Isolator
Viewport
Pressure
Accessories
Technical Reference

**Coaxial: 1/4" Diameter
.050 [1.3] Dia. Conductor**

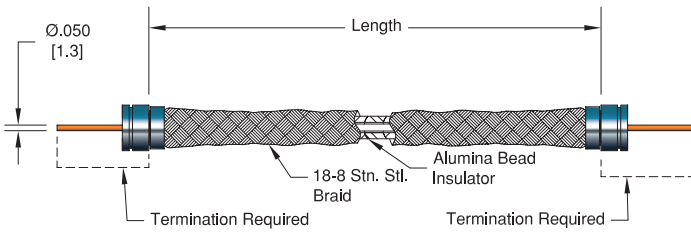

Termination A – Coaxial

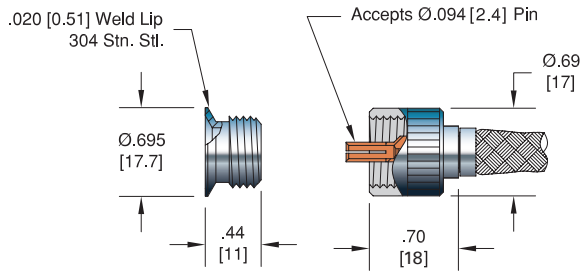

Termination B – Contact

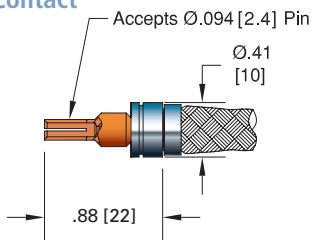

Termination C – In-Line

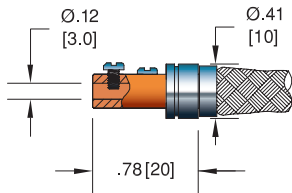

Termination – BNC & MHV

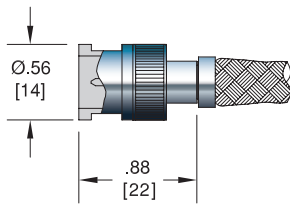

1/4" Cable Splice

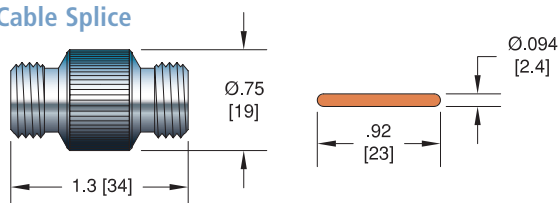

Note: For length greater than 36 inches, call for pricing and availability.

Coaxial Cables
1/4" Diameter



VOLTAGE DC	TERMINATION			LENGTH	CONDUCTOR AMPS	MATERIAL	TEMPERATURE °C		MAGNETIC MATERIALS	PART NUMBER
	END 1	END 2					MIN	MAX		
3 kV	A	A		12"	25	Zirconium Copper	-269	200	No	18681-12-AA
3 kV	A	B		12"	25	Zirconium Copper	-269	200	No	18681-12-AB
3 kV	A	C		12"	25	Zirconium Copper	-269	200	No	18681-12-AC
3 kV	A	BNC		12"	25	Zirconium Copper	-269	200	No	18681-12-AE
3 kV	A	MHV		12"	25	Zirconium Copper	-269	200	No	18681-12-AF
3 kV	B	B		12"	25	Zirconium Copper	-269	200	No	18681-12-BB
3 kV	B	C		12"	25	Zirconium Copper	-269	200	No	18681-12-BC
3 kV	C	C		12"	25	Zirconium Copper	-269	350	No	18681-12-CC
3 kV	A	A		24"	25	Zirconium Copper	-269	200	No	18681-24-AA
3 kV	A	B		24"	25	Zirconium Copper	-269	200	No	18681-24-AB
3 kV	A	C		24"	25	Zirconium Copper	-269	200	No	18681-24-AC
3 kV	A	BNC		24"	25	Zirconium Copper	-269	200	No	18681-24-AE
3 kV	A	MHV		24"	25	Zirconium Copper	-269	200	No	18681-24-AF
3 kV	B	B		24"	25	Zirconium Copper	-269	200	No	18681-24-BB
3 kV	B	C		24"	25	Zirconium Copper	-269	200	No	18681-24-BC
3 kV	C	C		24"	25	Zirconium Copper	-269	350	No	18681-24-CC
3 kV	A	A		36"	25	Zirconium Copper	-269	200	No	18681-36-AA
3 kV	A	B		36"	25	Zirconium Copper	-269	200	No	18681-36-AB
3 kV	A	C		36"	25	Zirconium Copper	-269	200	No	18681-36-AC
3 kV	A	BNC		36"	25	Zirconium Copper	-269	200	No	18681-36-AE
3 kV	A	MHV		36"	25	Zirconium Copper	-269	200	No	18681-36-AF
3 kV	B	B		36"	25	Zirconium Copper	-269	200	No	18681-36-BB
3 kV	B	C		36"	25	Zirconium Copper	-269	200	No	18681-36-BC
3 kV	C	C		36"	25	Zirconium Copper	-269	350	No	18681-36-CC

Cable Splice



SIZE	VOLTAGE DC	CONDUCTOR AMPS	MATERIAL	TEMPERATURE °C		MAGNETIC MATERIALS	PART NUMBER
				MIN	MAX		
1/4"	3 kV	25	Copper	-269	400	No	18728-01-A

Feedthrough

Multiple Connector

Coaxial

Thermocouple

Isolator

Viewport

Pressure

Accessories

Technical Reference

Feedthrough

Multipin Connector

Coaxial

Thermocouple

Isolator

Viewport

Pressure

Accessories

Technical Reference

In-Vacuum Ribbon Cable

CeramTec's in-vacuum ribbon cable is designed to complement our Micro D Type (MIL-DTL-83513) & Sub D Type (MIL-C-24308) hermetic multipin connector product lines and therefore cable configurations include 9, 15 or 25 conductor cable. Note that 50 conductor cables are created by using two 25 conductor cables. Each of the Kapton® wrapped stranded 28 AWG (7 x 0.005) or 22 AWG (19 x 0.0063) silver plated copper conductors are woven with a PEEK (polyether ether ketone) monofilament in order to achieve the ribbon cable form. The multistranded wrapped cable offers the most flexible solution and has a temperature range up to 200° C. All ribbon cable assembly materials are ultra-high vacuum (UHV) compatible. The ribbon cables are vacuum baked out prior to shipping. Additional vacuum bakeout is also recommended prior to use. All cable assembly components are sold separately.

28 AWG Ribbon Cable

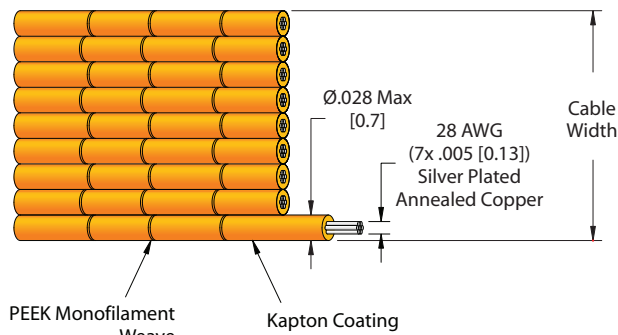

22 AWG Ribbon Cable

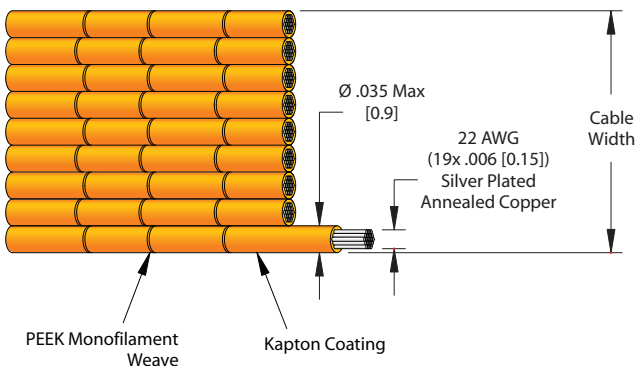

Single Conductor 28 AWG Stranded Wire

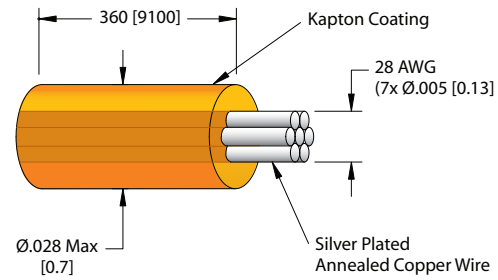

22 AWG Stranded Wire

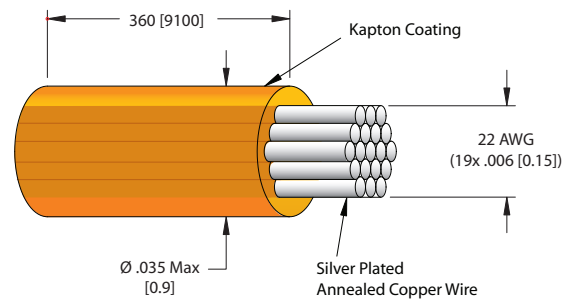

12 AWG Stranded Wire

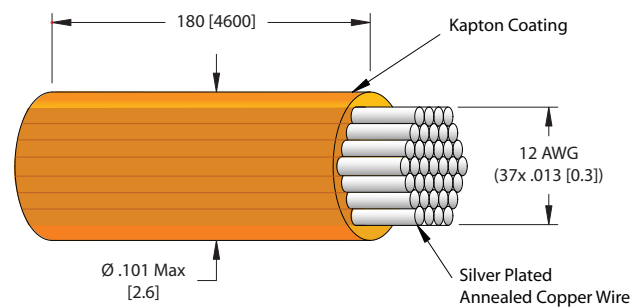

Specifications

Materials

Insulation: Kapton® Type FN
Weave: PEEK (polyether ether ketone) monofilament

Number of Conductors Single, 9, 15, 25

Conductor

28 AWG 7 / 0.005" stranded silver plated copper
22 AWG 19 / 0.0063" stranded silver plated copper
12 AWG 37 / 0.013" stranded silver plated copper

Voltage Rating 600 V AC, 850 V DC

Current Rating

28 AWG - 2.5 Amps per conductor
22 AWG - 5 Amps per conductor
12 AWG - 20 Amps per conductor

Temperature Range -55°C to 200°C

Resistance

28 AWG - 244 Ω/km at 20°C max.
22 AWG - 119 Ω/km at 20°C max.
12 AWG - 6.2 Ω/km at 20°C max.



VOLTAGE DC	CONDUCTOR AMPS	TYPE	LENGTH	WIRE DIAMETER	INSULATION DIAMETER	PART NUMBER
850 V	2.5	Stranded	30'	7 x 0.005	Ø .028	21621-01-A

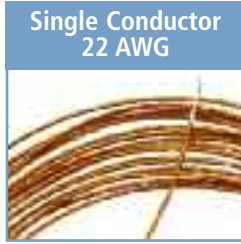

VOLTAGE DC	CONDUCTOR AMPS	TYPE	LENGTH	WIRE DIAMETER	INSULATION DIAMETER	PART NUMBER
850 V	5	Stranded	30'	19 x 0.0063	Ø .035	21643-01-A

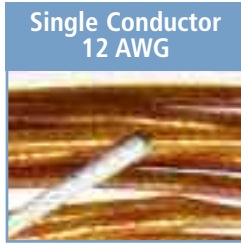

VOLTAGE DC	CONDUCTOR AMPS	TYPE	LENGTH	WIRE DIAMETER	INSULATION DIAMETER	PART NUMBER
850 V	20	Stranded	15'	37 x 0.013	Ø .101	21702-02-A



NO. WIRES	CABLE LENGTH	CABLE WIDTH	WIRE DIAMETER	INSULATION DIAMETER	PART NUMBER
9	19"	0.4	7 x 0.005	Ø .028	21622-19-WW
9	39"	0.4	7 x 0.005	Ø .028	21622-39-WW
9	96"	0.4	7 x 0.005	Ø .028	21622-96-WW
15	19"	0.7	7 x 0.005	Ø .028	21623-19-WW
15	39"	0.7	7 x 0.005	Ø .028	21623-39-WW
15	96"	0.7	7 x 0.005	Ø .028	21623-96-WW
25	19"	1.2	7 x 0.005	Ø .028	21624-19-WW
25	39"	1.2	7 x 0.005	Ø .028	21624-39-WW
25	96"	1.2	7 x 0.005	Ø .028	21624-96-WW



NO. WIRES	CABLE LENGTH	CABLE WIDTH	WIRE DIAMETER	INSULATION DIAMETER	PART NUMBER
9	19"	0.4	19 X 0.0063	Ø .035	20370-19-WW
9	39"	0.4	19 X 0.0063	Ø .035	20370-39-WW
9	96"	0.4	19 X 0.0063	Ø .035	20370-96-WW
15	19"	0.7	19 X 0.0063	Ø .035	20371-19-WW
15	39"	0.7	19 X 0.0063	Ø .035	20371-39-WW
15	96"	0.7	19 X 0.0063	Ø .035	20371-96-WW
25	19"	1.2	19 X 0.0063	Ø .035	20372-19-WW
25	39"	1.2	19 X 0.0063	Ø .035	20372-39-WW
25	96"	1.2	19 X 0.0063	Ø .035	20372-96-WW

Note that 50 conductor cables are created by using two 25 conductor cables.



DESCRIPTION	PART NUMBER
Adjustable wire stripper, 20-30 AWG (.25 - .80mm)	21128-01

Feedthrough

Multi-pin Connector

Coaxial

Thermocouple

Isolator

Viewport

Pressure

Accessories

Technical Reference

- Feedthrough
- Multipin Connector
- Coaxial
- Thermocouple
- Isolator
- Viewport
- Pressure
- Accessories
- Technical Reference

Standoffs

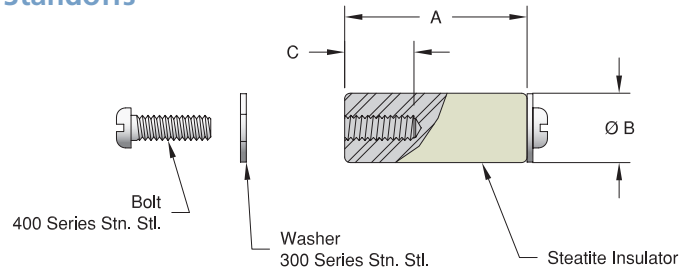

Ceramic Spacers

Number of Conductor Holes: 10

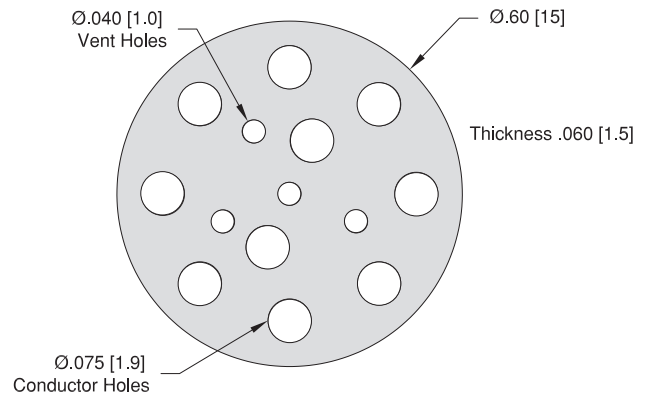

Number of Conductor Holes: 20

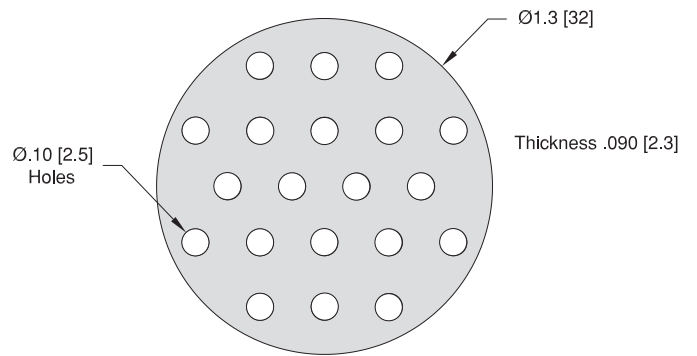

Number of Conductor Holes: 35

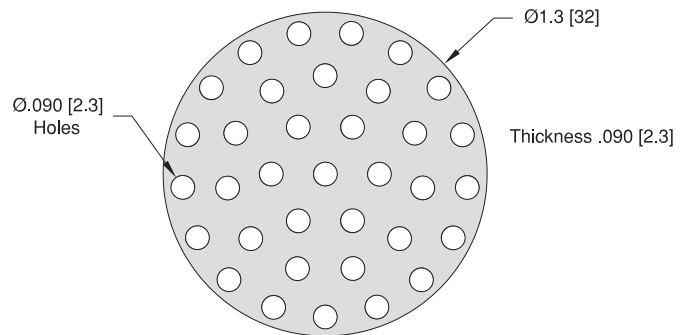

Standoffs
Steatite



THREAD SIZE	VOLTAGE		A	DIMENSIONS			TEMPERATURE °C		PART NUMBER
	DC (Vac)	DC (Air)		B	C	MIN	MAX		
6 – 32	10 kV	4 kV	0.50 [12.7]	0.38 [9.7]	0.16 [4.1]	-200	400	10420-01-A	
8 – 32	12 kV	5 kV	0.63 [16.0]	0.50 [12.7]	0.19 [4.8]	-200	400	10420-03-A	
6 – 32	20 kV	8 kV	1.00 [25.4]	0.38 [9.7]	0.38 [9.7]	-200	400	10420-02-A	
8 – 32	20 kV	8 kV	1.00 [25.4]	0.50 [12.7]	0.38 [9.7]	-200	400	10420-04-A	
10 – 32	20 kV	8 kV	1.00 [25.4]	0.75 [19.0]	0.38 [9.7]	-200	400	10420-06-A	
1/4 – 20	25 kV	10 kV	1.25 [31.8]	1.00 [25.4]	0.44 [11]	-200	400	10420-08-A	
8 – 32	35 kV	14 kV	2.00 [50.8]	0.50 [12.7]	0.38 [9.7]	-200	400	10420-05-A	
10 – 32	35 kV	14 kV	2.00 [50.8]	0.75 [19.0]	0.38 [9.7]	-200	400	10420-07-A	
1/4 – 20	40 kV	16 kV	2.50 [63.5]	1.00 [25.4]	0.63 [16]	-200	400	10420-09-A	

Ceramic Spacers
Alumina



NO. CONDUCTOR HOLES	TEMPERATURE °C		PART NUMBER
	MIN	MAX	
10	-269	800	3116-01-X
20	-269	800	1984-01-A
35	-269	800	10206-01

Feedthrough

Multiple Connector

Coaxial

Thermocouple

Isolator

Viewport

Pressure

Accessories

Technical Reference

Feedthrough
Multipin Connector
Coaxial
Thermocouple
Isolator
Viewport
Pressure
Accessories
Technical Reference

ConFlat Flanges
Size: 1 1/3" (NW16CF)

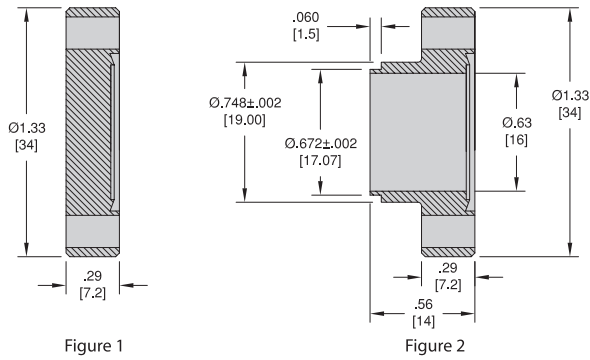

Size: 2 3/4" (NW35CF)

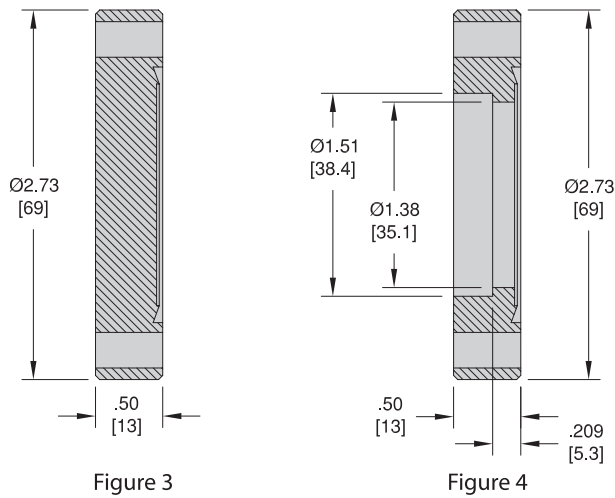

Size: 3 3/8" (NW50CF) & 4 1/2" (NW63CF)

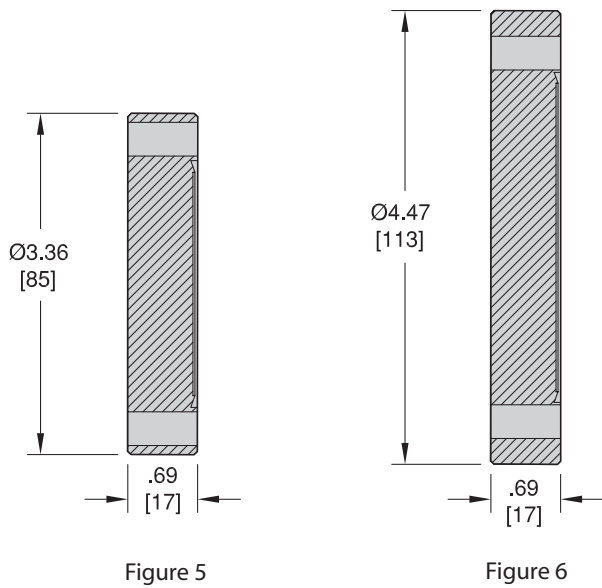

ISO KF Flanges
Type: Ported Weld Neck

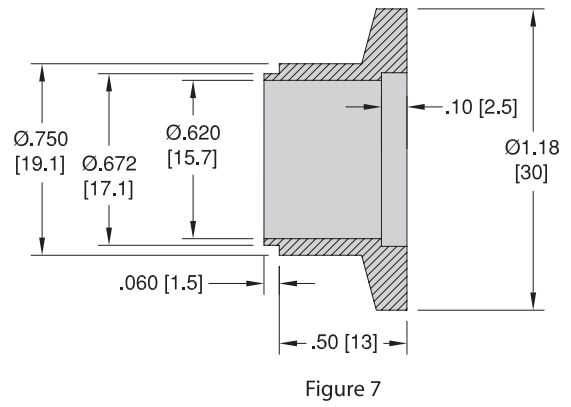

Type: Blank

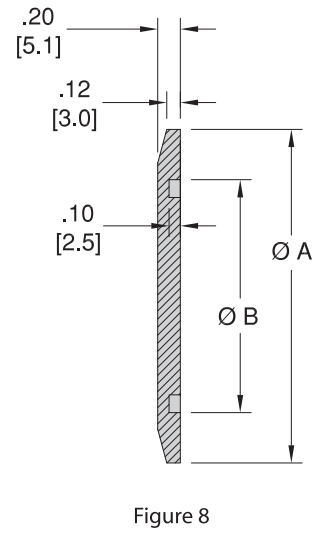

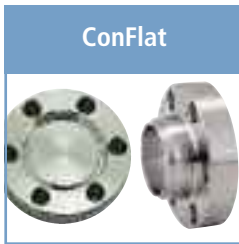

FLANGE CONFLAT	TYPE	FIGURE NUMBER	TEMPERATURE °C		PART NUMBER
			MIN	MAX	
1 1/3" (NW16CF)	Blank	1	-269	450	6463-01
1 1/3" (NW16CF)	Ported Weld Neck	2	-269	450	6863-01
2 3/4" (NW35CF)	Blank	3	-269	450	02899-01
2 3/4" (NW35CF)	Ported	4	-269	450	02899-02
3 3/8" (NW50CF)	Blank	5	-269	450	02899-13
4 1/2" (NW63CF)	Blank	6	-269	450	02899-03



FLANGE ISO	TYPE	FIGURE	DIMENSIONS		TEMPERATURE °C		PART NUMBER
			A	B	MIN	MAX	
NW16KF	Ported Weld Neck	7	.50 [13]	1.8 [30]	-25	205	17669-01
NW16KF	Blank	8	1.18 [30]	0.68 [17.3]	-25	205	13499-02
NW25KF	Blank	8	1.57 [40]	1.03 [26.2]	-25	205	13499-03
NW40KF	Blank	8	2.16 [55]	1.62 [41.0]	-25	205	13499-04
NW50KF	Blank	8	2.95 [75]	2.06 [52.3]	-25	205	13499-05

Алматы (727)345-47-04
Ангарск (3955)60-70-56
Архангельск (8182)63-90-72
Астрахань (8512)99-46-04
Барнаул (3852)73-04-60
Белгород (4722)40-23-64
Благовещенск (4162)22-76-07
Брянск (4832)59-03-52
Владивосток (423)249-28-31
Владикавказ (8672)28-90-48
Владимир (4922)49-43-18
Волгоград (844)278-03-48
Вологда (8172)26-41-59
Воронеж (473)204-51-73
Екатеринбург (343)384-55-89

Иваново (4932)77-34-06
Ижевск (3412)26-03-58
Иркутск (395)279-98-46
Казань (843)206-01-48
Калининград (4012)72-03-81
Калуга (4842)92-23-67
Кемерово (3842)65-04-62
Киров (8332)68-02-04
Коломна (4966)23-41-49
Кострома (4942)77-07-48
Краснодар (861)203-40-90
Красноярск (391)204-63-61
Курск (4712)77-13-04
Курган (3522)50-90-47
Липецк (4742)52-20-81

Магнитогорск (3519)55-03-13
Москва (495)268-04-70
Мурманск (8152)59-64-93
Набережные Челны (8552)20-53-41
Нижний Новгород (831)429-08-12
Новокузнецк (3843)20-46-81
Ноябрьск (3496)41-32-12
Новосибирск (383)227-86-73
Омск (3812)21-46-40
Орел (4862)44-53-42
Оренбург (3532)37-68-04
Пенза (8412)22-31-16
Петрозаводск (8142)55-98-37
Псков (8112)59-10-37
Пермь (342)205-81-47

Ростов-на-Дону (863)308-18-15
Рязань (4912)46-61-64
Самара (846)206-03-16
Санкт-Петербург (812)309-46-40
Саранск (8342)22-96-24
Саратов (845)249-38-78
Севастополь (8692)22-31-93
Симферополь (3652)67-13-56
Смоленск (4812)29-41-54
Сочи (862)225-72-31
Ставрополь (8652)20-65-13
Сургут (3462)77-98-35
Сыктывкар (8212)25-95-17
Тамбов (4752)50-40-97
Тверь (4822)63-31-35

Тольятти (8482)63-91-07
Томск (3822)98-41-53
Тула (4872)33-79-87
Тюмень (3452)66-21-18
Улан-Удэ (3012)59-97-51
Ульяновск (8422)24-23-59
Уфа (347)229-48-12
Хабаровск (4212)92-98-04
Чебоксары (8352)28-53-07
Челябинск (351)202-03-61
Череповец (8202)49-02-64
Чита (3022)38-34-83
Якутск (4112)23-90-97
Ярославль (4852)69-52-93

Россия +7(495)268-04-70

Казахстан +7(727)345-47-04

Беларусь +(375)257-127-884

Узбекистан +998(71)205-18-59

Киргизия +996(312)96-26-47