

# Дисковые и пластинчатые конденсаторы RF

## Технические характеристики

По вопросам продаж и поддержки обращайтесь:

Алматы (727)345-47-04  
Ангарск (3955)60-70-56  
Архангельск (8182)63-90-72  
Астрахань (8512)99-46-04  
Барнаул (3852)73-04-60  
Белгород (4722)40-23-64  
Благовещенск (4162)22-76-07  
Брянск (4832)59-03-52  
Владивосток (423)249-28-31  
Владикавказ (8672)28-90-48  
Владимир (4922)49-43-18  
Волгоград (844)278-03-48  
Вологда (8172)26-41-59  
Воронеж (473)204-51-73  
Екатеринбург (343)384-55-89

Иваново (4932)77-34-06  
Ижевск (3412)26-03-58  
Иркутск (395)279-98-46  
Казань (843)206-01-48  
Калининград (4012)72-03-81  
Калуга (4842)92-23-67  
Кемерово (3842)65-04-62  
Киров (8332)68-02-04  
Коломна (4966)23-41-49  
Кострома (4942)77-07-48  
Краснодар (861)203-40-90  
Красноярск (391)204-63-61  
Курск (4712)77-13-04  
Курган (3522)50-90-47  
Липецк (4742)52-20-81

Магнитогорск (3519)55-03-13  
Москва (495)268-04-70  
Мурманск (8152)59-64-93  
Набережные Челны (8552)20-53-41  
Нижний Новгород (831)429-08-12  
Новокузнецк (3843)20-46-81  
Ноябрьск (3496)41-32-12  
Новосибирск (383)227-86-73  
Омск (3812)21-46-40  
Орел (4862)44-53-42  
Оренбург (3532)37-68-04  
Пенза (8412)22-31-16  
Петрозаводск (8142)55-98-37  
Псков (8112)59-10-37  
Пермь (342)205-81-47

Ростов-на-Дону (863)308-18-15  
Рязань (4912)46-61-64  
Самара (846)206-03-16  
Санкт-Петербург (812)309-46-40  
Саратов (845)249-38-78  
Севастополь (8692)22-31-93  
Саранск (8342)22-96-24  
Симферополь (3652)67-13-56  
Смоленск (4812)29-41-54  
Сочи (862)225-72-31  
Ставрополь (8652)20-65-13  
Сургут (3462)77-98-35  
Сыктывкар (8212)25-95-17  
Тамбов (4752)50-40-97  
Тверь (4822)63-31-35

Тольятти (8482)63-91-07  
Томск (3822)98-41-53  
Тула (4872)33-79-87  
Тюмень (3452)66-21-18  
Ульяновск (8422)24-23-59  
Улан-Удэ (3012)59-97-51  
Уфа (347)229-48-12  
Хабаровск (4212)92-98-04  
Чебоксары (8352)28-53-07  
Челябинск (351)202-03-61  
Череповец (8202)49-02-64  
Чита (3022)38-34-83  
Якутск (4112)23-90-97  
Ярославль (4852)69-52-93

Россия +7(495)268-04-70

Казахстан +(727)345-47-04

Беларусь +(375)257-127-884

Узбекистан +998(71)205-18-59

Киргизия +996(312)96-26-47

эл.почта: [cgc@nt-rt.ru](mailto:cgc@nt-rt.ru) || сайт: <https://ceramtec.nt-rt.ru>

# RF Decoupling Class 2

## Capacitors 3.5 kV Discs

The CeramTec Group is a world leader in the design and manufacture of complex electronic ceramic components and assemblies used in a wide range of applications and cutting edge technologies. CeramTec UK specialises in the development and production of dielectric and ferroelectric materials and components. This disc range is designed for high frequency decoupling applications and as such complements CeramTec's extensive range of CLASS 1 RF Power Capacitors. It is fabricated from a Y5U CLASS 2 ceramic dielectric material.

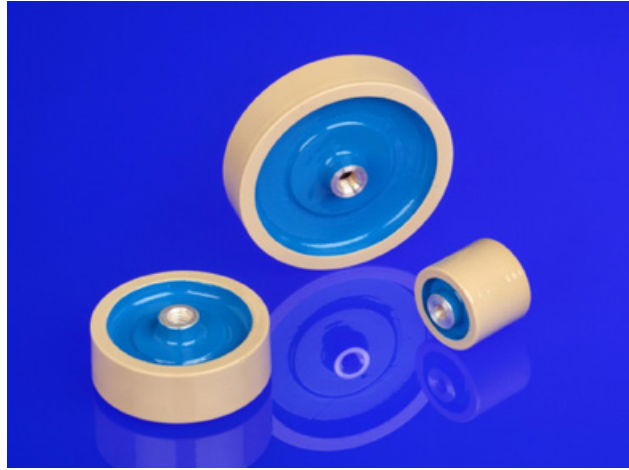

### APPLICATION

- HF Decoupling Circuits

Material/Electrical Specification	
Capacitance Range	1000 – 15000pF (see table)
Capacitance Tolerance	+40 % -20 %
Capacitance Temperature Characteristic	Y5U (EIA) See curve (+22% -56% from -30°C to +85°C)
Rated Voltage (dc+acpk)	3.5 kVpk (see table)
Test Voltage (50Hz)	5kVrms/60sec
RF kVAR load rating	See table
RF current rating	See table
Operating Temperature Range	-25°C +85°C
Maximum Relative Humidity	75 %

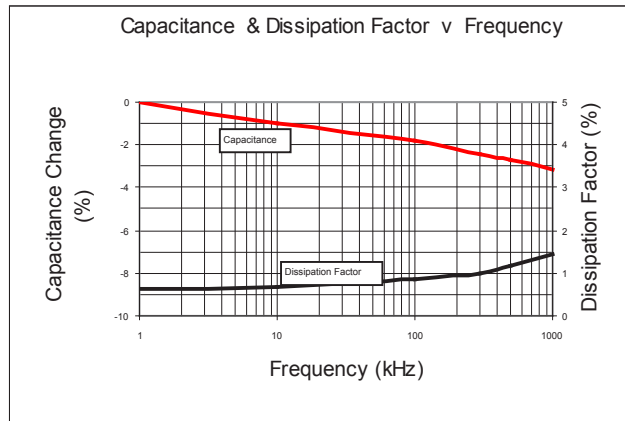
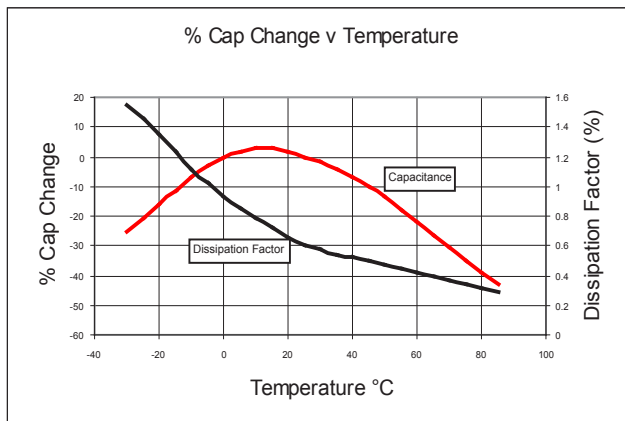

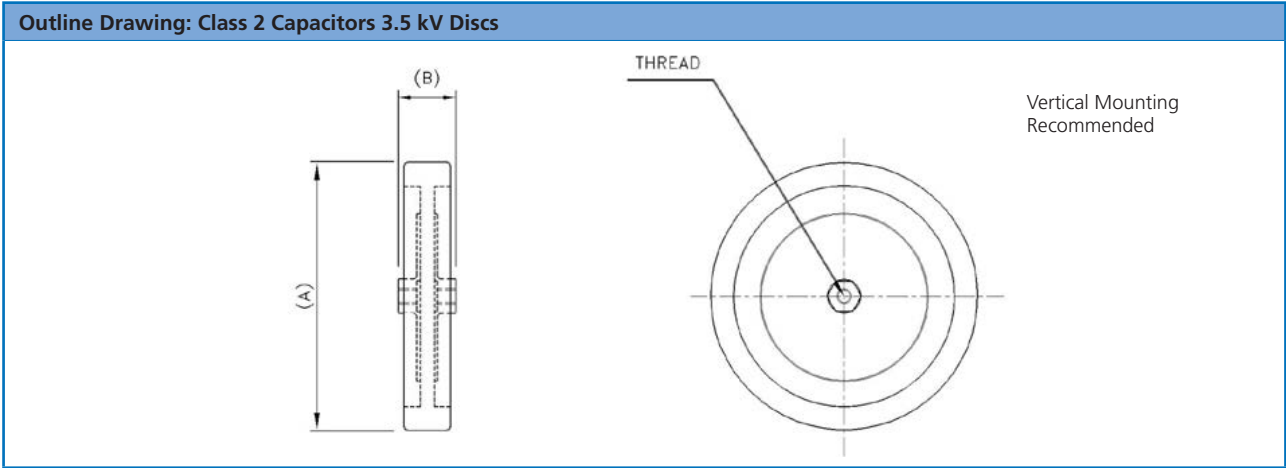

**Electrical Characteristics – CLASS 1 Ceramic Discs**

Type No	Cap Value pF	Temp Charc	Rated (ACpk + DC) kVpk	Rated AC kVpk	Test 50 Hz kVrms	Max POWER Rating (kVAr)	Max Current Rating (A rms)	A nom (mm)	B nom (mm)	Thread Size (mm)
855	1000	Y5U	3.5	3.5	5	0.25	5	23	17-24	M4
856	2200	Y5U	3.5	3.5	5	0.25	9	33	17-24	M4
856	3300	Y5U	3.5	3.5	5	0.5	9	33	17-24	M4
857	4700	Y5U	3.5	3.5	5	1	15	45	17-24	M6
857	6800	Y5U	3.5	3.5	5	1	15	45	17-24	M6
858	10000	Y5U	3.5	3.5	5	1	15	57	17-24	M6
858	15000	Y5U	3.5	3.5	5	1	15	57	17-24	M6

The above RF load conditions are based on the maximum body temperature rise of 45°C from an ambient temperature of 30°C.

# RF Power Capacitors Class1

## 5kV Discs

The CeramTec Group is a world leader in the design and manufacture of complex electronic ceramic components and assemblies used in a wide range of applications and cutting edge technologies. CeramTec UK specialises in the development and production of dielectric and ferroelectric materials and components. This range of high voltage RF discs capacitors is fabricated from very low loss CLASS 1 ceramic dielectric materials which permit them to carry very high electrical loads over a wide frequency range.

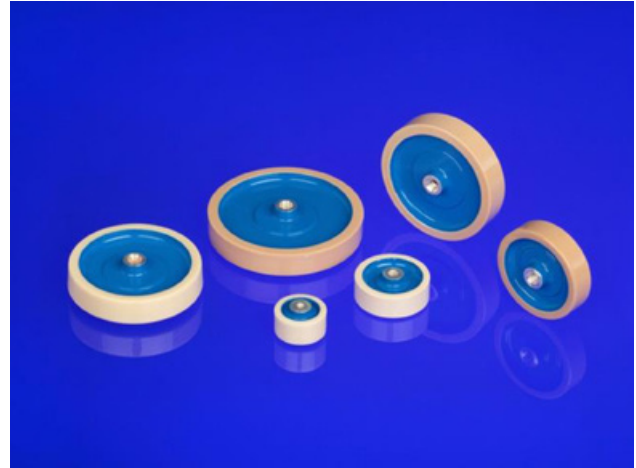

### APPLICATIONS INCLUDE

- Radio Broadcast Transmitters
- Induction and Dielectric Heating Equipment
- HF Filter, By-Pass & Coupling Circuits
- High Power Matching Tuned Circuits
- Antenna Circuits
- Industrial Applications
- High Power matching networks –Plasma Generators
- High quality medical imaging systems (MRI)

### FEATURES

- Low loss Class 1 ceramic dielectric materials with noble metal electrodes resulting in low self heating.
- High Voltage / High Reactive Power Ratings
- Very low NPO capacitance-temperature characteristics available that result in correspondingly low tuned frequency drift.
- Low Inductance construction permitting higher frequency use.
- Low magnetic susceptibility

Material Characteristics						
Dielectric Constant @ 20°C / 1 MHz		15	36	77	90	190
Temperature Coefficient of Capacitance	ppm/°C	+100 ±60	0 ±30	0 ±30	-750 ±80	-1300 ±120
Tan δ 1 MHz (Cap ≤ 1000 pF)	x 10 <sup>-4</sup>	≤ 5	≤ 5	≤ 5	≤ 5	≤ 5
Tan δ 1 kHz (Cap > 1000 pF)	x 10 <sup>-4</sup>	≤ 10	≤ 10	≤ 10	≤ 10	≤ 10
Dielectric Strength	kVmm <sup>-1</sup> dc	22	20	15	10	10
Volume Resistivity	Ωm	10 <sup>13</sup>	10 <sup>13</sup>	10 <sup>13</sup>	10 <sup>13</sup>	10 <sup>13</sup>

Electrical Specification	
Capacitance Range	10 – 2000pF (see table)
Capacitance Tolerance	±20 % ±10 % Consult factory for other tolerances
Rated RF Voltage	5kV pk (see table)
Test Voltage	√2 x Rated Voltage / 60sec
RF Voltage, Current & kVA <sub>r</sub> Load v Frequency	See RF rating curves
Operating Temperature Range	-25°C +95°C
Maximum Relative Humidity	75 %

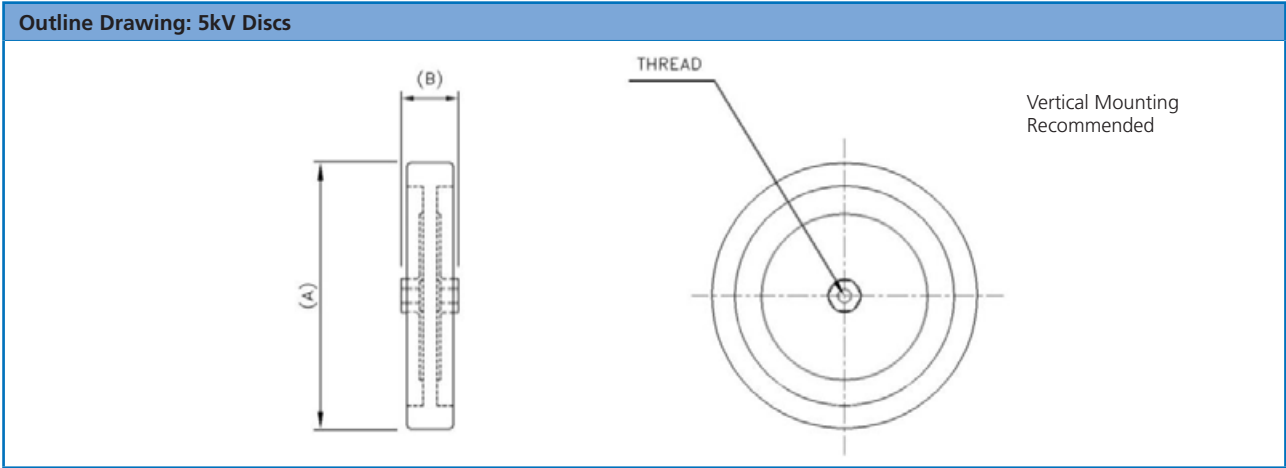

Electrical Characteristics										
Type No	Cap Value pF	TCC ppm/ °C	Rated (ACpk + DC) kVpk	Rated AC kVpk	Test 50 Hz kVrms	Max POWER Rating (kVAr)	Max Current Rating (A rms)	A nom (mm)	B nom (mm)	Thread Size (mm)
831	120	-1300	5	5	7.5	10	8	23	18	M4
831	150	-1300	5	5	7.5	10	8	23	17	M4
831	180	-1300	5	5	7.5	10	8	23	15	M4
831	220	-1300	5	5	7.5	10	8	23	14	M4
832	220	-1300	5	5	7.5	20	11	33	18	M4
832	270	-1300	5	5	7.5	20	11	33	17	M4
832	330	-1300	5	5	7.5	20	11	33	16	M4
832	390	-1300	5	5	7.5	20	11	33	14	M4
833	390	-1300	5	5	7.5	30	15	45	19	M6
833	470	-1300	5	5	7.5	30	15	45	17	M6
833	560	-1300	5	5	7.5	30	15	45	16	M6
833	680	-1300	5	5	7.5	30	15	45	15	M6
834	680	-1300	5	5	7.5	40	18	57	19	M6
834	820	-1300	5	5	7.5	40	18	57	18	M6
834	1000	-1300	5	5	7.5	40	18	57	17	M6
834	1200	-1300	5	5	7.5	40	18	57	15	M6
835	1200	-1300	5	5	7.5	50	24	73	19	M6
835	1500	-1300	5	5	7.5	50	24	73	17	M6
835	2000	-1300	5	5	7.5	50	24	73	15	M6
836	50	-750	5	5	7.5	25	8	23	18	M4
836	68	-750	5	5	7.5	25	8	23	17	M4
836	82	-750	5	5	7.5	25	8	23	16	M4
836	100	-750	5	5	7.5	25	8	23	14	M4
837	100	-750	5	5	7.5	30	11	33	16	M4
837	150	-750	5	5	7.5	30	11	33	14	M4
837	200	-750	5	5	7.5	30	11	33	13	M4

# RF Power Capacitors Class1

## 5kV Discs

Electrical Characteristics										
Type No	Cap Value pF	TCC ppm/ °C	Rated (ACpk + DC) kVpk	Rated AC kVpk	Test 50 Hz kVrms	Max POWER Rating (kVAr)	Max Current Rating (A rms)	A nom (mm)	B nom (mm)	Thread Size (mm)
838	200	-750	5	5	7.5	40	15	45	19	M6
838	270	-750	5	5	7.5	40	15	45	18	M6
838	330	-750	5	5	7.5	40	15	45	17	M6
838	370	-750	5	5	7.5	40	15	45	15	M6
839	350	-750	5	5	7.5	55	18	57	19	M6
839	470	-750	5	5	7.5	55	18	57	17	M6
839	600	-750	5	5	7.5	55	18	57	15	M6
840	750	-750	5	5	7.5	65	24	73	19	M6
840	1000	-750	5	5	7.5	65	24	73	15	M6

Electrical Characteristics										
Type No	Cap Value pF	TCC ppm/ °C	Rated (ACpk + DC) kVpk	Rated AC kVpk	Test 50 Hz kVrms	Max POWER Rating (kVAr)	Max Current Rating (A rms)	A nom (mm)	B nom (mm)	Thread Size (mm)
841	20	0	5	5	7.5	25	8	23	18	M4
841	25	0	5	5	7.5	25	8	23	16	M4
841	30	0	5	5	7.5	25	8	23	14	M4
842	30	0	5	5	7.5	30	8	23	18	M4
842	39	0	5	5	7.5	30	11	33	17	M4
842	47	0	5	5	7.5	30	11	33	15	M4
842	68	0	5	5	7.5	30	11	33	14	M4
843	70	0	5	5	7.5	40	15	45	19	M4
843	100	0	5	5	7.5	40	15	45	17	M4
843	120	0	5	5	7.5	40	15	45	15	M4
844	120	0	5	5	7.5	55	18	57	19	M6
844	150	0	5	5	7.5	55	18	57	18	M6
844	180	0	5	5	7.5	55	18	57	17	M6
844	220	0	5	5	7.5	55	18	57	15	M6
845	270	0	5	5	7.5	65	24	73	19	M6
845	330	0	5	5	7.5	65	24	73	17	M6
845	390	0	5	5	7.5	65	24	73	15	M6
846	10	+100	5	5	7.5	25	8	23	18	M4
846	12	+100	5	5	7.5	25	8	23	16	M4
846	15	+100	5	5	7.5	25	8	23	14	M4
847	15	+100	5	5	7.5	30	11	33	18	M4
847	22	+100	5	5	7.5	30	11	33	16	M4
847	27	+100	5	5	7.5	30	11	33	15	M4
847	33	+100	5	5	7.5	30	11	33	14	M4
848	24	+100	5	5	7.5	40	15	45	19	M6
848	33	+100	5	5	7.5	40	15	45	18	M6
848	39	+100	5	5	7.5	40	15	45	17	M6
848	47	+100	5	5	7.5	40	15	45	16	M6
848	56	+100	5	5	7.5	40	15	45	15	M6
849	66	+100	5	5	7.5	55	18	57	19	M6
849	82	+100	5	5	7.5	55	18	57	17	M6
849	100	+100	5	5	7.5	55	18	57	15	M6
850	130	+100	5	5	7.5	65	24	73	19	M6
850	150	+100	5	5	7.5	65	24	73	17	M6
850	180	+100	5	5	7.5	65	24	73	15	M6

# RF Power Capacitors Class1

## 5kV Discs

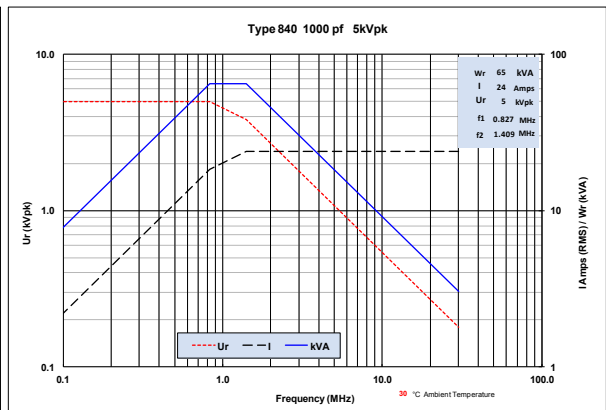
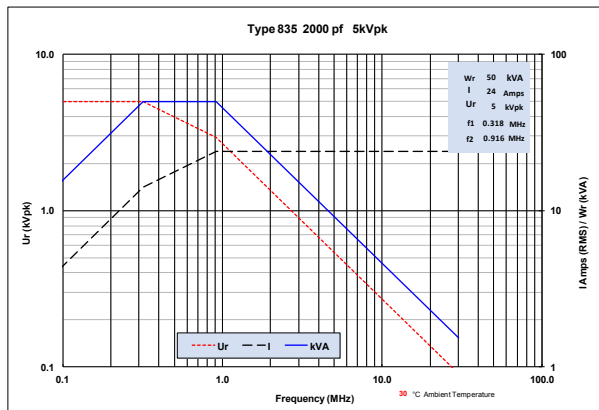
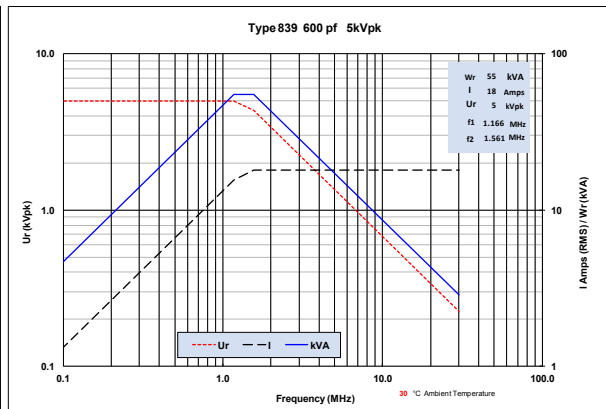
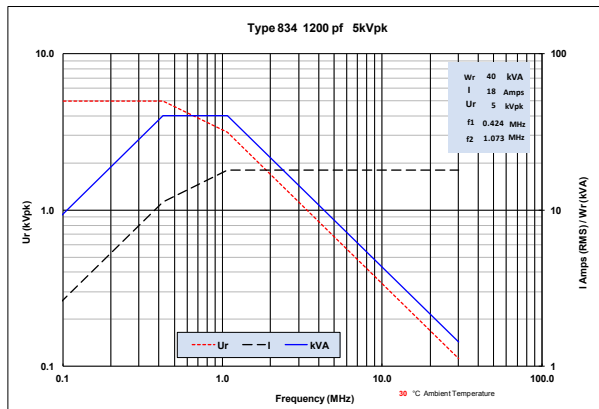
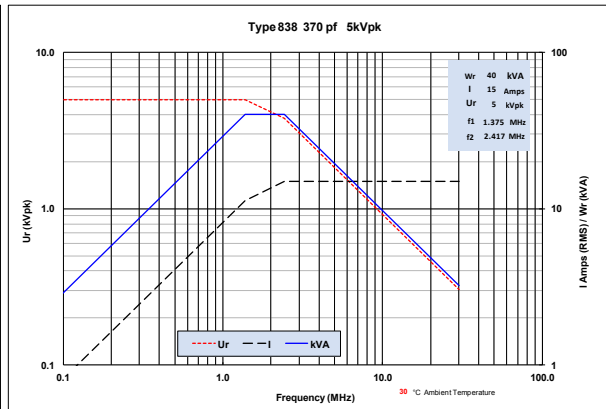
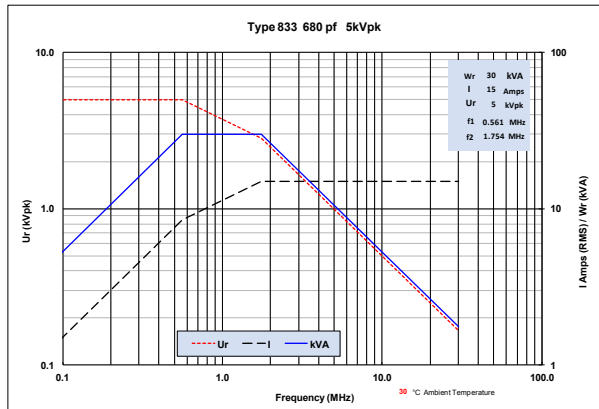
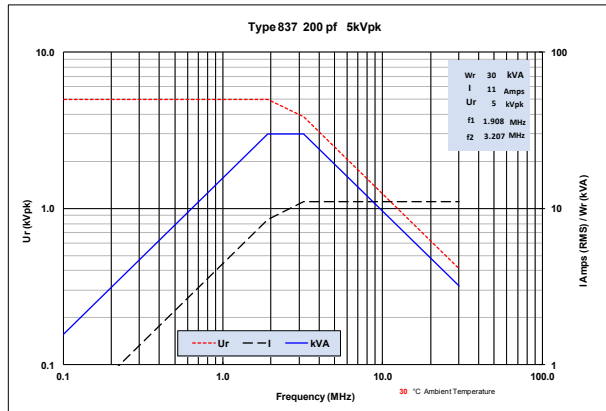
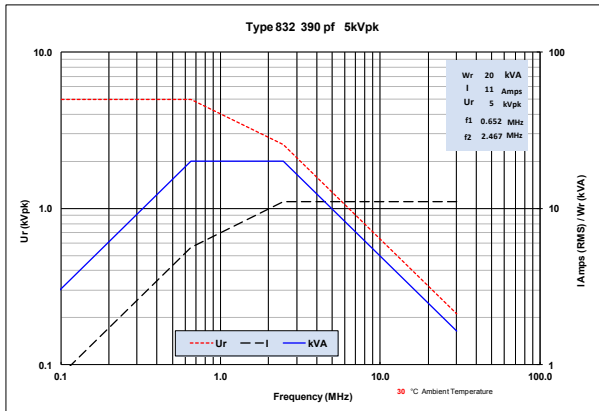

The above RF load conditions are based on the maximum body temperature rise of 45°C from an ambient temperature of 30°C.



# RF POWER CAPACITORS CLASS 1

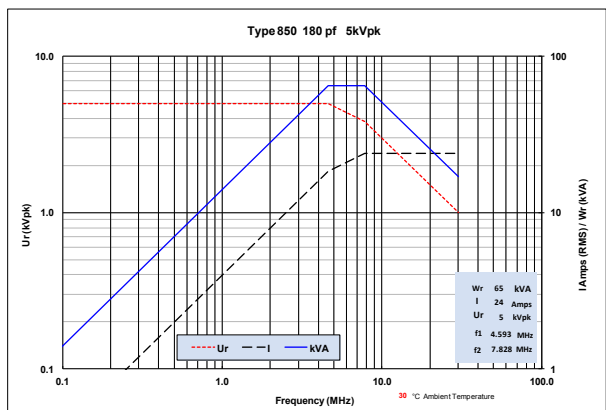
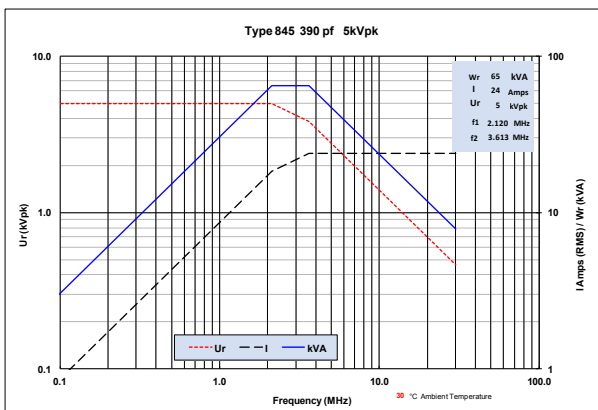
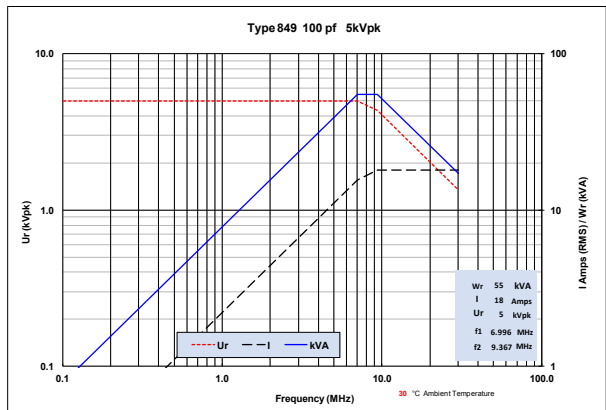
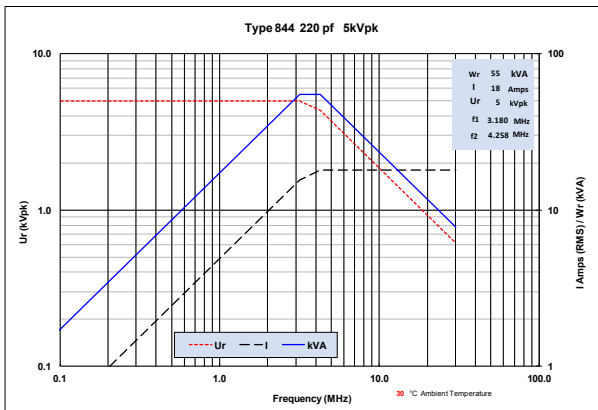
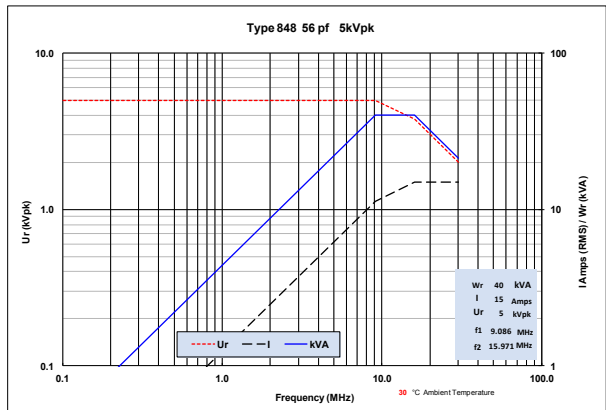
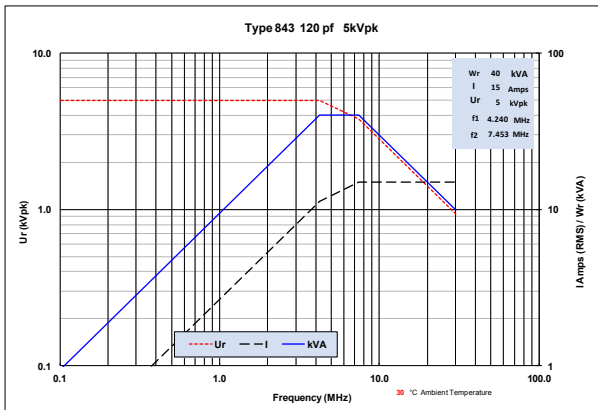
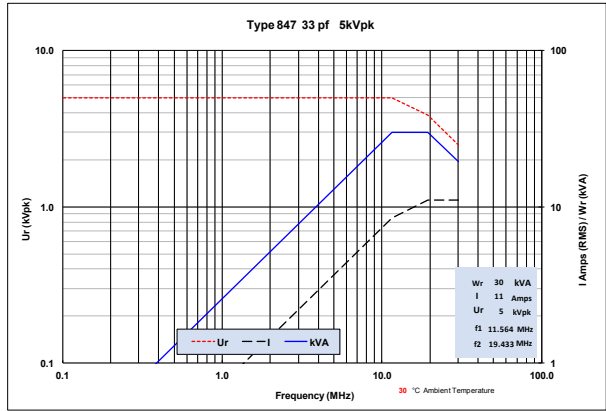
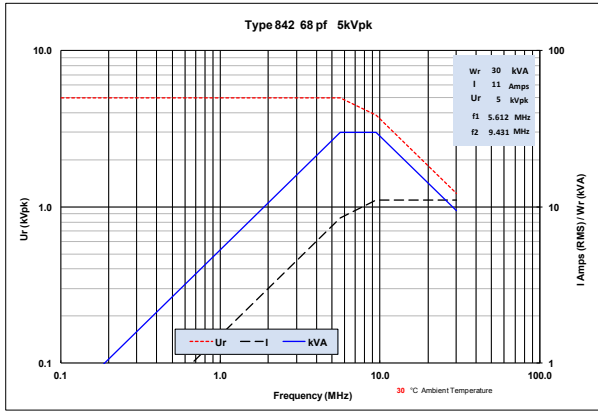

The above RF load conditions are based on the maximum body temperature rise of 45°C from an ambient temperature of 30°C.

## По вопросам продаж и поддержки обращайтесь:

Алматы (727)345-47-04  
Ангарск (3955)60-70-56  
Архангельск (8182)63-90-72  
Астрахань (8512)99-46-04  
Барнаул (3852)73-04-60  
Белгород (4722)40-23-64  
Благовещенск (4162)22-76-07  
Брянск (4832)59-03-52  
Владивосток (423)249-28-31  
Владикавказ (8672)28-90-48  
Владимир (4922)49-43-18  
Волгоград (844)278-03-48  
Вологда (8172)26-41-59  
Воронеж (473)204-51-73  
Екатеринбург (343)384-55-89

Иваново (4932)77-34-06  
Ижевск (3412)26-03-58  
Иркутск (395)279-98-46  
Казань (843)206-01-48  
Калининград (4012)72-03-81  
Калуга (4842)92-23-67  
Кемерово (3842)65-04-62  
Киров (8332)68-02-04  
Коломна (4966)23-41-49  
Кострома (4942)77-07-48  
Краснодар (861)203-40-90  
Красноярск (391)204-63-61  
Курск (4712)77-13-04  
Курган (3522)50-90-47  
Липецк (4742)52-20-81

Магнитогорск (3519)55-03-13  
Москва (495)268-04-70  
Мурманск (8152)59-64-93  
Набережные Челны (8552)20-53-41  
Новокузнецк (3843)20-46-81  
Ноябрьск (3496)41-32-12  
Новосибирск (383)227-86-73  
Омск (3812)21-46-40  
Орел (4862)44-53-42  
Оренбург (3532)37-68-04  
Пенза (8412)22-31-16  
Петрозаводск (8142)55-98-37  
Псков (8112)59-10-37  
Пермь (342)205-81-47

Ростов-на-Дону (863)308-18-15  
Рязань (4912)46-61-64  
Самара (846)206-03-16  
Санкт-Петербург (812)309-46-40  
Саратов (845)249-38-78  
Севастополь (8692)22-31-93  
Саранск (8342)22-96-24  
Симферополь (3652)67-13-56  
Смоленск (4812)29-41-54  
Сочи (862)225-72-31  
Ставрополь (8652)20-65-13  
Сургут (3462)77-98-35  
Сыктывкар (8212)25-95-17  
Тамбов (4752)50-40-97  
Тверь (4822)63-31-35

Тольятти (8482)63-91-07  
Томск (3822)98-41-53  
Тула (4872)33-79-87  
Тюмень (3452)66-21-18  
Ульяновск (8422)24-23-59  
Улан-Удэ (3012)59-97-51  
Уфа (347)229-48-12  
Хабаровск (4212)92-98-04  
Чебоксары (8352)28-53-07  
Челябинск (351)202-03-61  
Череповец (8202)49-02-64  
Чита (3022)38-34-83  
Якутск (4112)23-90-97  
Ярославль (4852)69-52-93

**Россия** +7(495)268-04-70

**Казахстан** +(727)345-47-04

**Беларусь** +(375)257-127-884

**Узбекистан** +998(71)205-18-59

**Киргизия** +996(312)96-26-47

эл.почта: [cgc@nt-rt.ru](mailto:cgc@nt-rt.ru) || сайт: <https://ceramtec.nt-rt.ru>