

Формы для окунания из технической керамики для производства перчаток

Технические характеристики

По вопросам продаж и поддержки обращайтесь:

Алматы (727)345-47-04
Ангарск (3955)60-70-56
Архангельск (8182)63-90-72
Астрахань (8512)99-46-04
Барнаул (3852)73-04-60
Белгород (4722)40-23-64
Благовещенск (4162)22-76-07
Брянск (4832)59-03-52
Владивосток (423)249-28-31
Владикавказ (8672)28-90-48
Владимир (4922)49-43-18
Волгоград (844)278-03-48
Вологда (8172)26-41-59
Воронеж (473)204-51-73
Екатеринбург (343)384-55-89

Иваново (4932)77-34-06
Ижевск (3412)26-03-58
Иркутск (395)279-98-46
Казань (843)206-01-48
Калининград (4012)72-03-81
Калуга (4842)92-23-67
Кемерово (3842)65-04-62
Киров (8332)68-02-04
Коломна (4966)23-41-49
Кострома (4942)77-07-48
Краснодар (861)203-40-90
Красноярск (391)204-63-61
Курск (4712)77-13-04
Курган (3522)50-90-47
Липецк (4742)52-20-81

Магнитогорск (3519)55-03-13
Москва (495)268-04-70
Мурманск (8152)59-64-93
Набережные Челны (8552)20-53-41
Нижний Новгород (831)429-08-12
Новокузнецк (3843)20-46-81
Ноябрьск (3496)41-32-12
Новосибирск (383)227-86-73
Омск (3812)21-46-40
Орел (4862)44-53-42
Оренбург (3532)37-68-04
Пенза (8412)22-31-16
Петрозаводск (8142)55-98-37
Псков (8112)59-10-37
Пермь (342)205-81-47

Ростов-на-Дону (863)308-18-15
Рязань (4912)46-61-64
Самара (846)206-03-16
Санкт-Петербург (812)309-46-40
Саратов (845)249-38-78
Севастополь (8692)22-31-93
Саранск (8342)22-96-24
Симферополь (3652)67-13-56
Смоленск (4812)29-41-54
Сочи (862)225-72-31
Ставрополь (8652)20-65-13
Сургут (3462)77-98-35
Сыктывкар (8212)25-95-17
Тамбов (4752)50-40-97
Тверь (4822)63-31-35

Тольятти (8482)63-91-07
Томск (3822)98-41-53
Тула (4872)33-79-87
Тюмень (3452)66-21-18
Ульяновск (8422)24-23-59
Улан-Удэ (3012)59-97-51
Уфа (347)229-48-12
Хабаровск (4212)92-98-04
Чебоксары (8352)28-53-07
Челябинск (351)202-03-61
Череповец (8202)49-02-64
Чита (3022)38-34-83
Якутск (4112)23-90-97
Ярославль (4852)69-52-93

Россия +7(495)268-04-70

Казахстан +(727)345-47-04

Беларусь +(375)257-127-884

Узбекистан +998(71)205-18-59

Киргизия +996(312)96-26-47

эл.почта: cgc@nt-rt.ru || сайт: <https://ceramtec.nt-rt.ru>

Dipping Formers



Material Properties

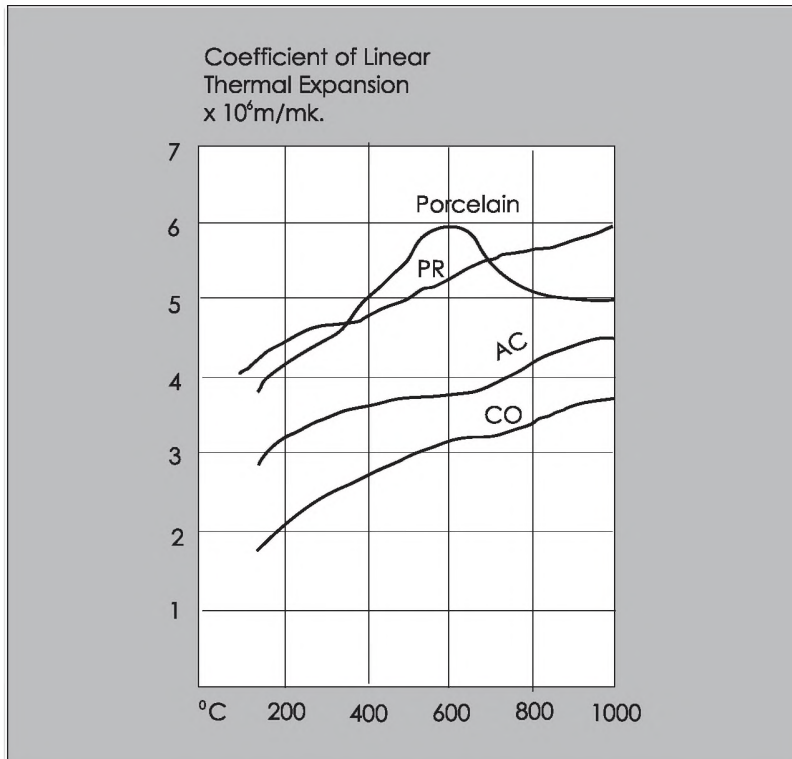

CeramTec which is an ISO 9001 : 2015 accredited company has developed special materials for the production of dipping formers most suited to the manufacture of gloves.

Material PR:

This material is used to make dipping formers for Latex, Nitrile and other synthetic gloves. The special merits of this material are high durability and an outstanding resistance to corrosive conditions.

Material AC:

This material is used to make dipping formers for the manufacture of Vinyl gloves and for the autoclaving vulcanizing process.

This material has a low expansion coefficient and a good thermal shock resistance.

Material CO:

This material is used to make dipping formers for PVC industrial gloves. These have a very low expansion coefficient and very good thermal shock resistance.

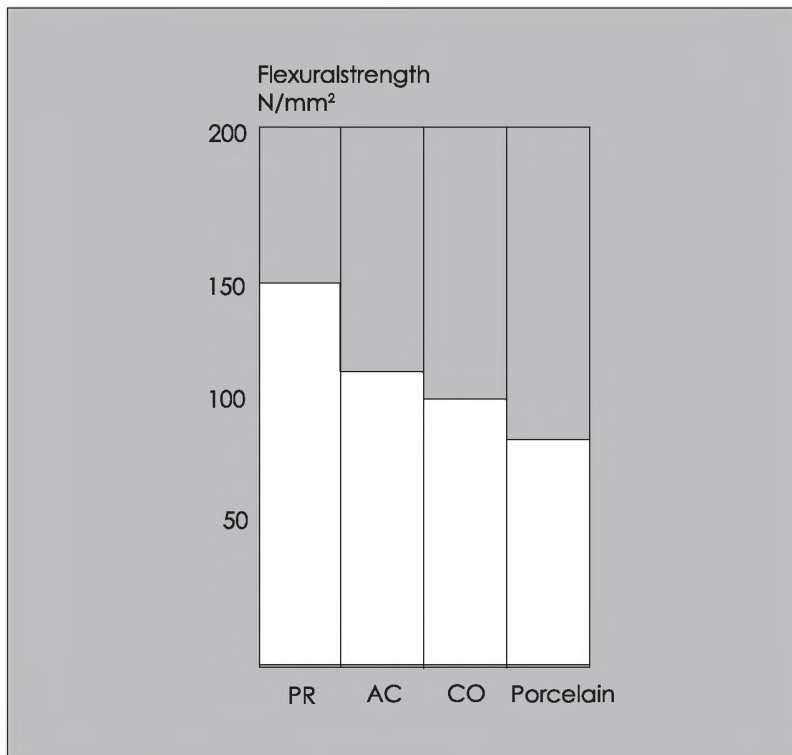

CeramTec quality dipping formers have the following material properties.

1. A low and constant Coefficient of Thermal Expansion.
2. High Flexural Strength.
3. A very fine and uniform microstructure that resists corrosion. (See figures 1, 2 and 3).

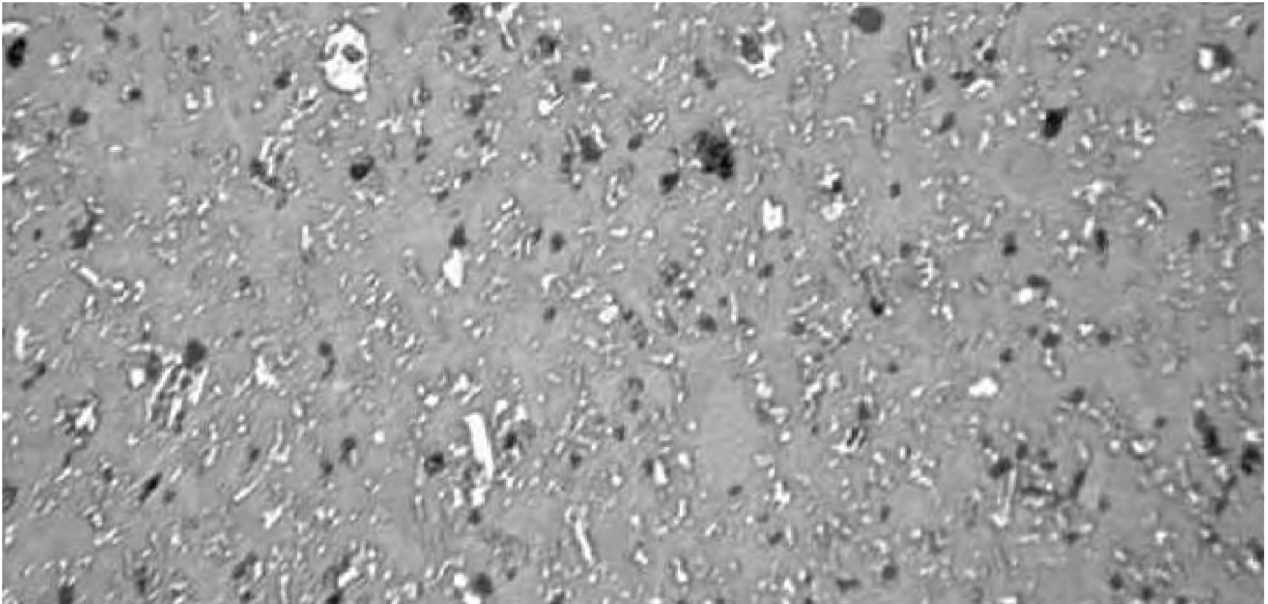

Microstructure of our PR material x 200

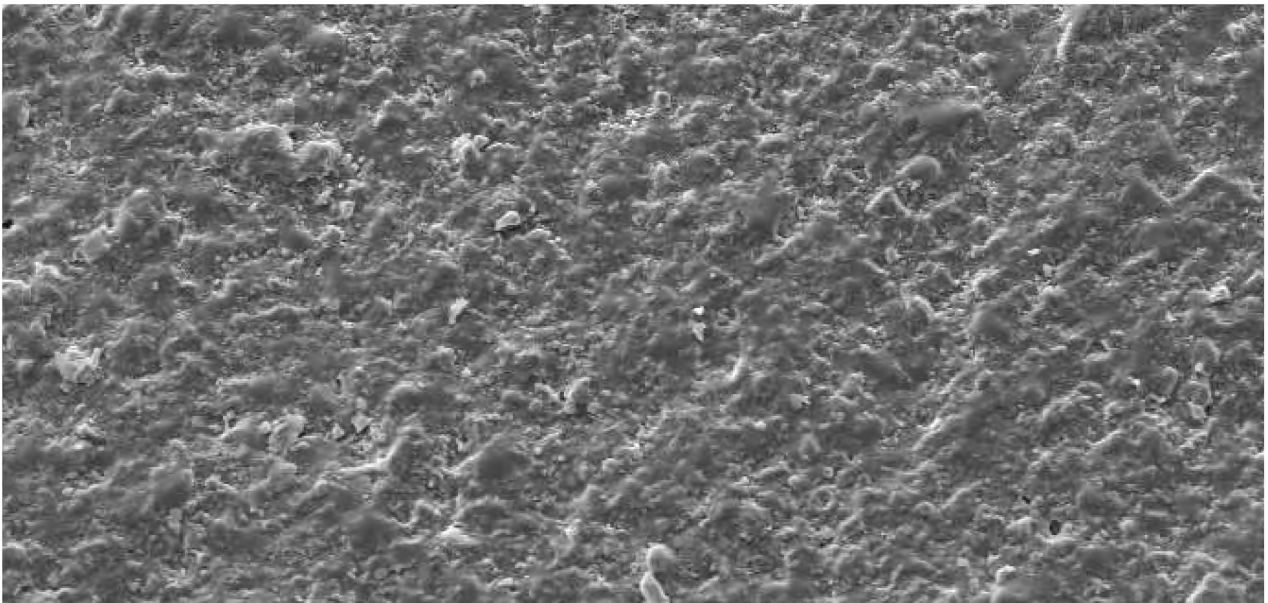

Surface taken by our scanning electron microscope x 200

Wall Thickness And Heat Retention

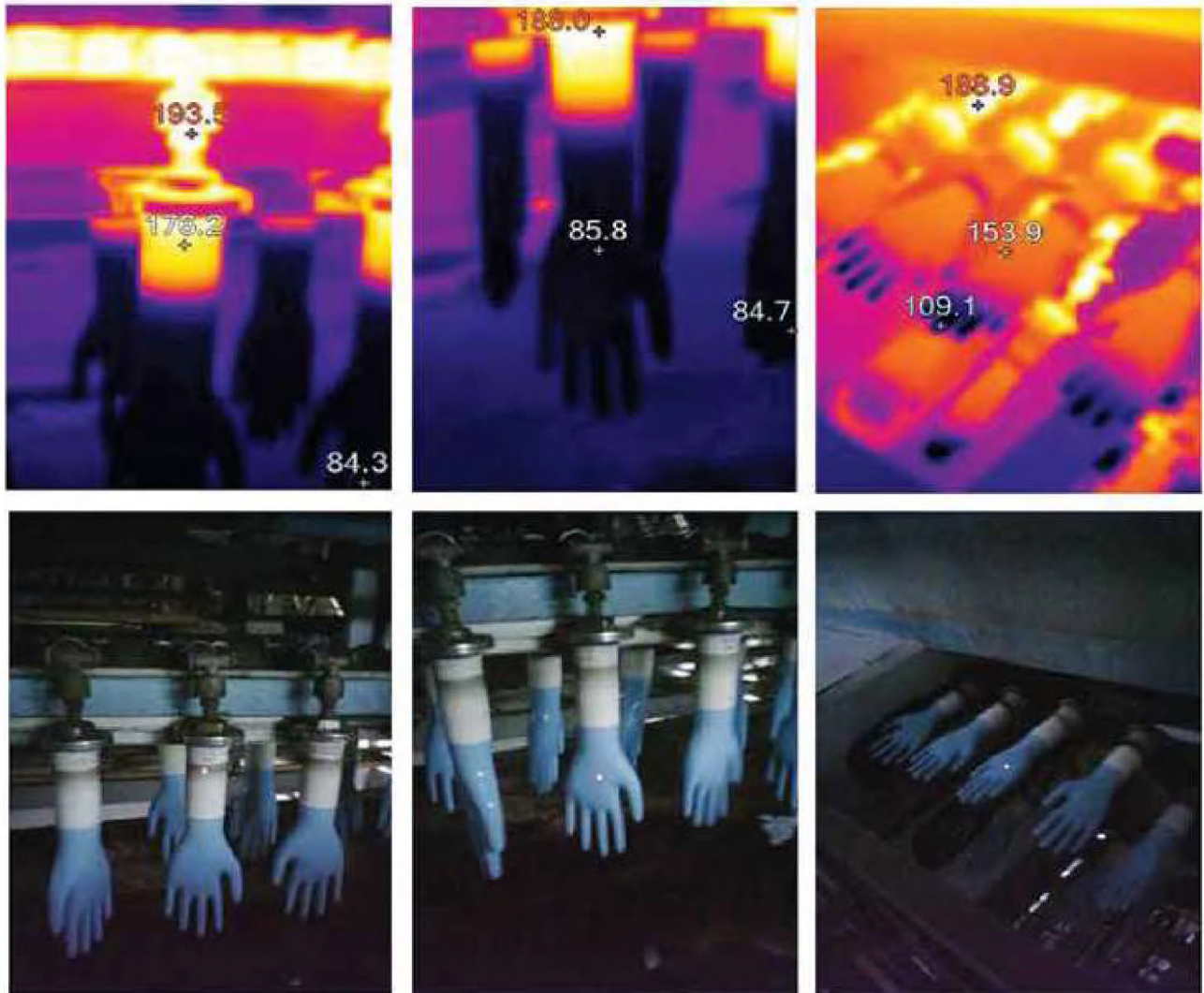

Different wall thickness of former will create different heat retention properties. This factor is critical in the dipping process as different thickness of gloves will be produced.

Infra-red thermovision photos show the different heat retention and heat distribution among dipped formers.

CeramTec guarantees a uniform and tight wall thickness tolerance of $\pm 0.5\text{mm}$ from its fully automated slip casting machines.

Dipping Formers - Standard Types

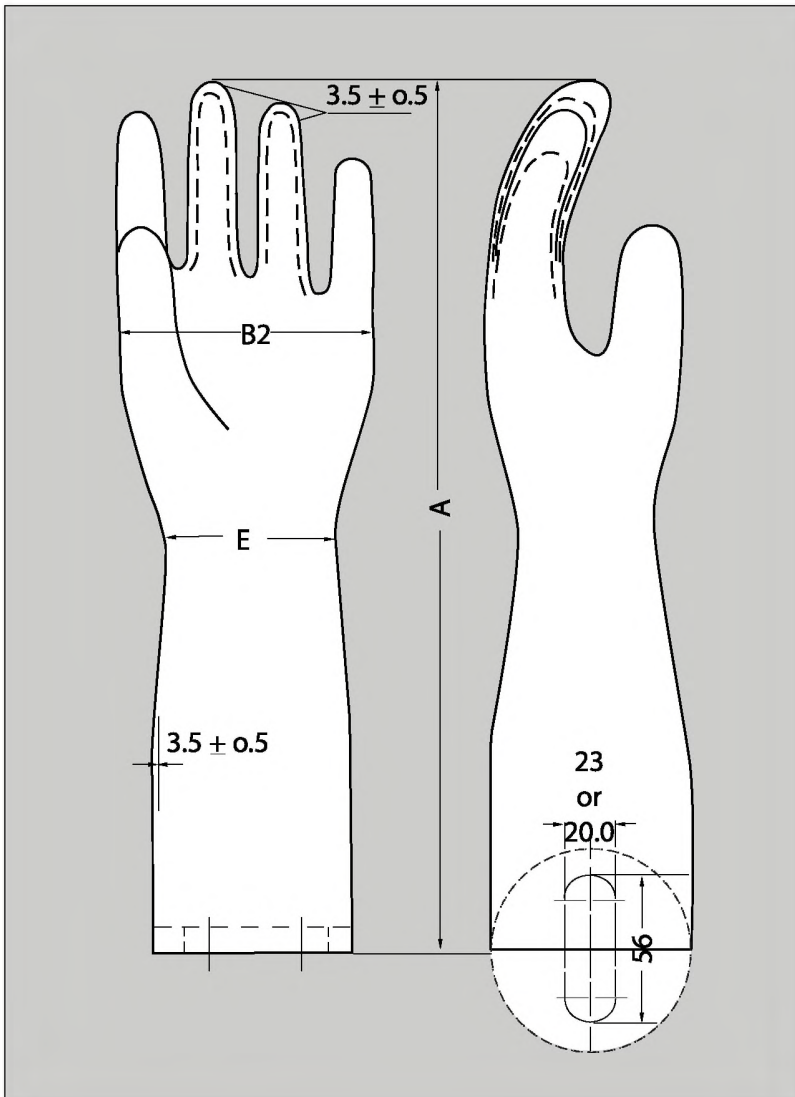

Customers are requested to pay particular attention to the measurements shown in our catalogue when selecting standard models. Please note the:

- Palm circumference
- Wrist circumference
- Overall length

The relief pattern shown on standard models relate to the corresponding type under the term R. These standard patterns can be applied to any former produced by CeramTec or to the customer designed former. Models are produced for the customer on a cost sharing basis. For new designs, Please see the guideline on pages 10/13.

We recommend a material thickness of 3.5mm. Due to our mechanized production method we are in the position to offer a wall thickness tolerance of ± 0.5 mm.

The wall thickness can be varied to suit customers' requirements. Variation may be necessary for very large or small formers. In all cases the tolerances of ± 0.5 mm can be held.

The fingers are always hollow and also have well controlled thickness.

The preferred standard dimensions for the bottom slots are either 23 x 56.0mm or 20.0 x 56.0mm; however, special dimensions are possible.

On formers shown in this catalogue used to produce household gloves, there are several options available for size markings. In addition to the standard numerals, sizes may be indicated with words or with letters such as SMALL or S and LARGE or L. These standard size markings are available from extra small through extra large sizes. Additionally, CeramTec offers customers size markings based upon customer request.

Spray - Roughened Surface Textures

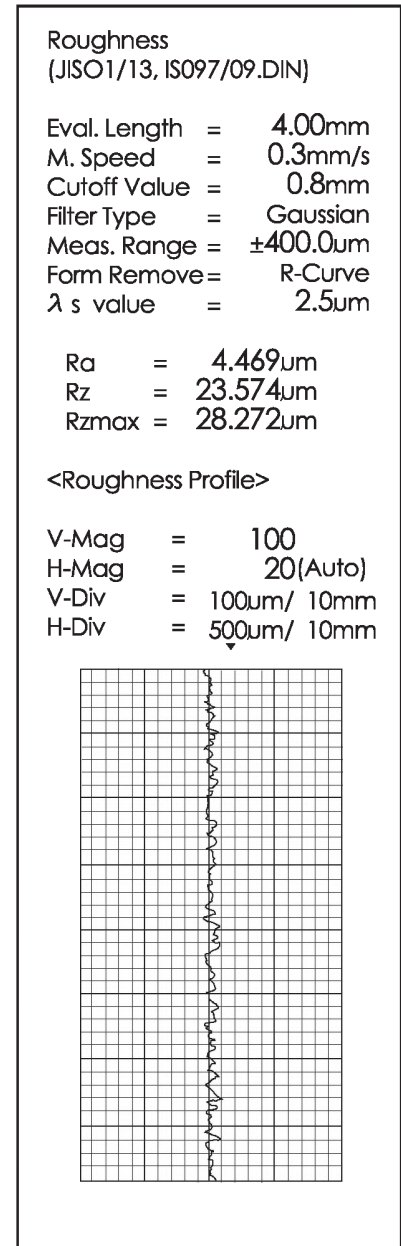
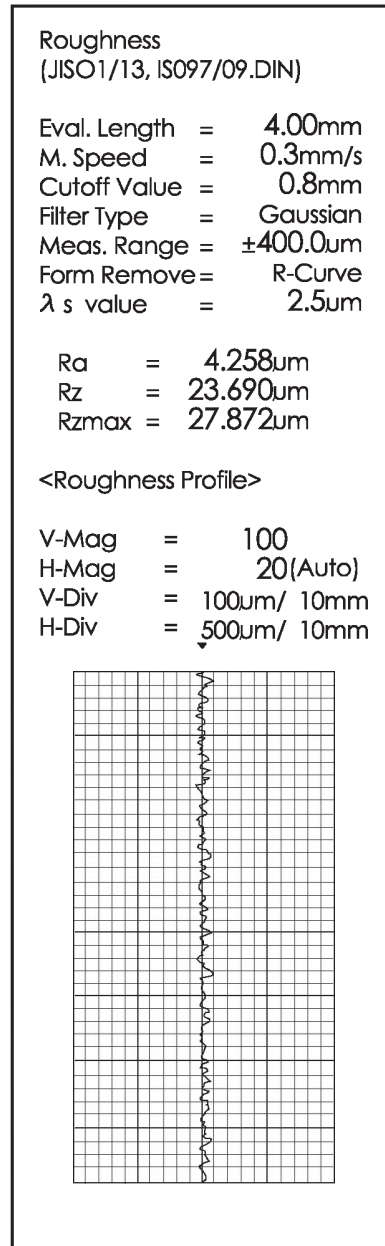
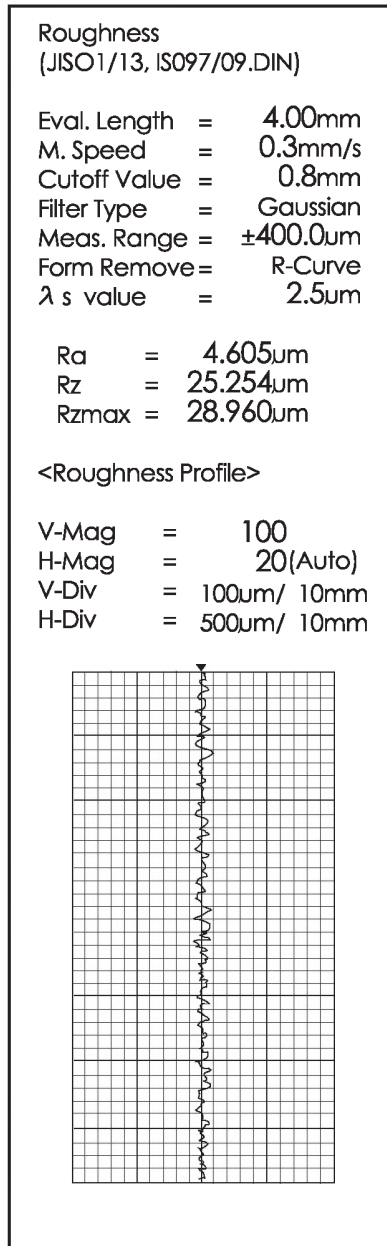

Different sprayed finishes are available to roughen the surfaces of surgical, household and industrial glove formers.

A smooth sprayed finish can be used for the surface treatment of household formers to improve the dipping performance.

Consistency of former surface texture is critical to ensure FAB and Tensile properties of glove are equally consistent.

Surgical Glove Formers



Type S1

Size	6.5	7	7.5	8	8.5
Height	370	370	370	370	370
Palm Circ.	172	180	190	204	214
Wrist Circ.	155	166	181	199	217



Type S2

Size	6	6.5	7	7.5	8	8.5
Height	405	405	415	415	415	415
Palm Circ.	164	176	188	203	214	225
Wrist Circ.	133	144	155	164	174	181



Type S3

Size	6	6.5	7	7.5	8	8.5	9
Height	400	400	400	400	400	400	400
Palm Circ.	160	170	183	198	210	222	236
Wrist Circ.	136	146	153	162	170	183	191

Surgical Glove Formers



Type S4

Size	6.5	7	7.5	8	8.5	9	9.5
Height	400	408	408	408	408	408	408
Palm Circ.	180	193	206	221	232	242	255
Wrist Circ.	153	160	171	182	190	200	208



Type S5

Size	6.5	7.5A	8A	8.5A
Height	530	530	530	530
Palm Circ.	184	206	221	233
Wrist Circ.	147	162	173	184



Type S6

Size	6.5	7	7.5	8	8.5
Height	400	400	400	400	400
Palm Circ.	170	183	198	210	222
Wrist Circ.	146	153	162	170	183

Surgical Glove Formers



Type S7

Size	5.5F	6F	6.5F	7F	7.5F	8F	8.5F	9F
Height	405	405	405	405	405	405	405	405
Palm Circ.	156	167	177	192	204	216	231	244
Wrist Circ.	134	144	152	164	173	183	195	207



Type S8

Size	5.5	6	6.5	7	7.5	8	8.5	9
Height	368	368	368	360	376	377	386	386
Palm Circ.	150	163	173	183	196	210	226	237
Wrist Circ.	125	137	151	160	169	208	222	234



Type S9

Size	5.5	6	6.5	7B	7.5	8	8.5	9
Height	385	385	385	385	397	397	397	397
Palm Circ.	149	163	175	188	200	214	226	240
Wrist Circ.	129	138	147	156	163	174	185	192

Surface Patterns for Gloves

Each of the illustrated patterns can be applied on every type of former.



Pattern R5



Pattern R9a



Pattern R10



Pattern R14



Pattern R15



Pattern R25



Pattern R30



Pattern R40



Pattern R70



Pattern R77



Pattern R20



Pattern R89



Pattern R99



Pattern R100



Pattern R104



Pattern R126



Pattern R126f



Pattern R129



Pattern R132



Pattern R162



Pattern R166



Pattern R167



Pattern R169



Pattern R177



Pattern R187



Pattern R193



Pattern R220

Special Surface Pattern Designs

Examples shown in the illustrations are for special designs in the shaft area produced in accordance with customer's requests. (Some of the designs shown are proprietary)



Straight grooves



Floral pattern



Ornamental pattern



Dual shaft and stretch band



Stretchband



Flutes



Ventilation grooves



Ornamental pattern



Dual shaft and stretch band

Household Glove Formers



Type HH1

Size	7.5	8	8.5	9	9.5
Height	380	380	380	380	380
Palm Circ.	200	211	217	229	238
Wrist Circ.	178	186	195	203	213
Pattern	R41	R41	R41	R41	R41



Type HH2

Size	6.5	7	7.5	8	8.5	9	9.5	10	10.5	11.5
Height	386	386	386	386	386	386	386	386	386	386
Palm Circ.	181	193	198		209	216	228	237	248	267
Wrist Circ.	159	168	175	182	193	203	210	217	224	
Pattern	R14	R14	R14	R14	R14	R14	R14			
Pattern	R89	R89	R89	R89	R89	R89				
Pattern			R126	R126	R126	R126	R126	R126	R126	
Pattern	R129a	129a	129a	129a	129a	129a	129a		129a	129a
Pattern		RV99			RV99					



Type HH3

Size	7	8	8.5	9	9.5
Height	370	370	370	370	391
Palm Circ.	186	202	219	236	243
Wrist Circ.	203	209	221	227	240
Pattern	R9a	R9a	R9a	R9a	R9a
Pattern	R177	R177	R177		

Household Glove Formers



Type HH4

Size	8	8.5	9	9.5	10
Height	400	400	400	400	400
Palm Circ.	197	216	232	253	270
Wrist Circ.	182	204	222	237	251
Pattern	R5	R5	R5	R5	R5



Type HH5

Size	6	7	8	9
Height	420	420	420	420
Palm Circ.	198	217	232	258
Wrist Circ.	178	199	221	246
Pattern	R99	R99	R99	R99
Pattern	R343	R343	R343	R343



Type HH6

Size	6	7	8	9
Height	415	415	415	415
Palm Circ.	199	222	240	264
Wrist Circ.	175	191	214	241
Pattern	R343	R343	R343	R343

Household Glove Formers



Type HH7

Size	8	8.5	9	9.5	10
Height	400	400	400	400	400
Palm Circ.	197	216	232	253	273
Wrist Circ.	182	204	222	239	250
Pattern	R5	R5	R5	R5	R5



Type HH7

Size	8	8.5	9	9.5	10
Height	400	400	400	400	400
Palm Circ.	197	216	232	253	273
Wrist Circ.	182	204	222	239	250
Pattern	R10	R10	R10	R10	



Type HH7

Size	8	8.5	9	9.5	10
Height	400	400	400	400	400
Palm Circ.	197	216	232	253	273
Wrist Circ.	182	204	222	239	250
Pattern	R132	R132	R132	R132	

Industrial Glove Formers



Type I1

Size	6	6.5	7	7.5	8	8.5	9	9.5	10	10.5
Height	369	369	380	380	380	380	380	380	380	380
Palm Circ.	188	194	202	207	218	225	233	238	242	250
Wrist circ.	175	182	190	198	205	213	224	229	237	247



Type I2

Size	11
Height	800
Palm Circ.	297
Wrist Circ.	303



Type I3

Size	9	10	12
Height	800	800	800
Palm Circ.	252	274	331
Wrist Circ.	248	275	323

Industrial Glove Formers



Type I4

Size	6	7	8	9	10	11
Height	478	478	478	478	478	478
Palm Circ.	206	228	246	256	267	292
Wrist Circ.	198	216	219	233	239	252



Type I5

Size	10	11
Height	560	560
Palm Circ.	265	288
Wrist Circ.	258	274
Pattern	R155S	R155S



Type I6

Size	8	9A	10	11	12
Height	570	570	570	570	570
Palm Circ.	234	264	281	302	325
Wrist Circ.	230	259	278	302	323

Examination Glove Formers



Type E1

Size	6	7F	7.5	8	9C
Height	377	377	377	377	377
Palm Circ.	167	172	201	223	244
Wrist Circ.	141	145	165	182	203



Type E2

Size	6A	6.5A	7.5C	8.5	9
Height	406	406	406	406	406
Palm Circ.	174	185	206	217	242
Wrist Circ.	176	194	218	234	245



Type E3

Size	5	6	7	8	9
Height	352	352	352	352	352
Palm Circ.	163	185	209	231	255
Wrist Circ.	141	159	188	195	210

Examination Glove Formers



Type E4

Size	7	8	9
Height	325	325	325
Palm Circ.	182	204	233
Wrist Circ.	158	179	192



Type E5

Size	6	6.5	7.5	8	9
Height	400	400	400	400	400
Palm Circ.	157	176	200	222	240
Wrist Circ.	151	166	180	193	205



Type E6

Size	5.5	6.5	7.5	8.5	9.5
Height	400	400	400	400	400
Palm Circ.	168	177	200	225	235
Wrist Circ.	151	163	180	193	204

Special Shapes



Type S1

Condom Former



Type S2

Ballon Former



Type S3

Special Ballon Former



Type S4

Ceramic Plates

* Special shapes are available on made to order basis.

Decades of experience in our factory's modelling department and our specially trained and experienced personnel enable CeramTec to produce models to customers' specifications on short notice.

By means of special modelling techniques, exact reproduction and pattern uniformity are assured on a long term basis.

Although CeramTec develops exclusive models to the design of our customers, we also have a large number of standard models available.

Our standard tolerances are:

- A) Material thickness $\pm 0.5\text{mm}$
- B) Height less than 400 $\pm 4\text{ mm}$
400 - 555mm $\pm 1.5\%$
- C) Circumference : $\pm 2\%$ of nominal values
 : $\pm 3\%$ for fingers
- D) Finger Length : $\pm 3\%$
- E) Rotation radius (measured from the vertical line)

 $\pm 12\text{mm}$ as a standard

 $\pm 6\text{mm}$ after grinding the base
 Plate at additional cost

Tighter customer tolerances can be provided upon request.

Dimensional Design

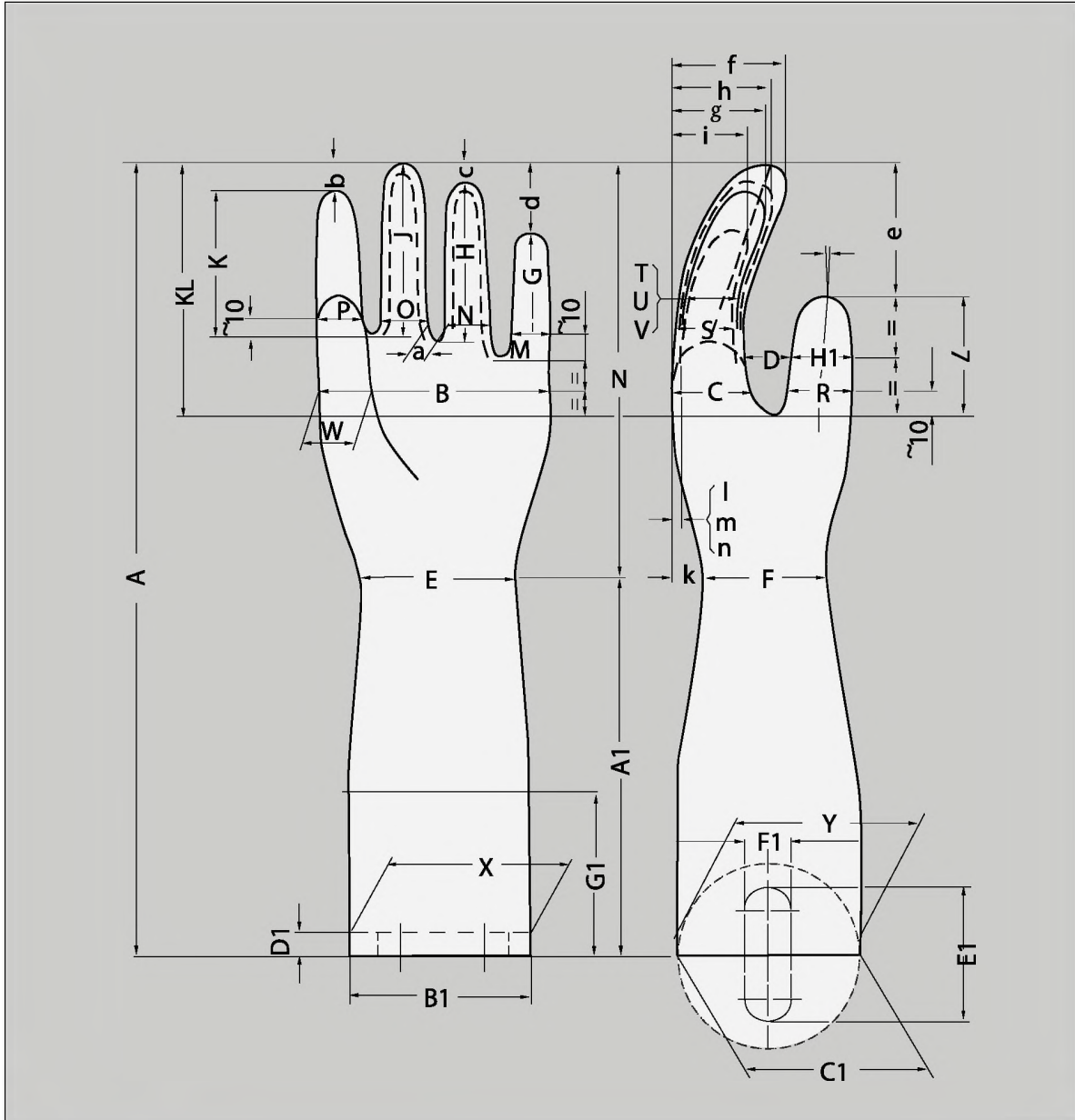

When requesting modifications or new designs, the following guideline should be used to determine the desired dimensions.

Circumference dimensions B2, E2 etc. are measured at B, E etc.

The base plate of the former should be a standard shape.

total length		A
breadth of palm		B
palm circumference		B 2
width of palm		C
distance thumb - index		D
breadth of wrist		E
wrist circumference		E 2
width of wrist		F
Distribution thumb crotch / index finger tip		KL
Finger lengths	little finger	G
	ring finger	H
	middle finger	J
	index finger	K
	thumb	L
Breadth of fingers	little finger	M
	ring finger	N
	middle finger	O
	index finger	P
	thumb	R
Finger circumferences	little finger	M 2
	ring finger	N 2
	middle finger	O 2
	index finger	P 2
	thumb	R 2
Width of fingers	little finger	S
	ring finger	T
	middle finger	U
	index finger	V
	thumb	W
breadth of shank		X
shank circumference		X 2
width of shank		Y
length of hand		Z
distance between fingers		a
Distance from tip	index finger	b
	ring finger	c
	little finger	d
	thumb	e
Curvature	middle finger	f
	index	g
	ring finger	h
	little finger	i
distance tip of index - thumb crotch		kl
distance back of hand - index		l
distance back of hand - ring finger		m
distance back of hand - little finger		n
height of wrist		A 1
breadth of socket		B 1
width of socket		C 1
height of socket		D 1
length of socket slot		E 1
breadth of socket slot		F 1
height of cylindrical shank		G 1
Rotation radius		

Assembly

To mount the former onto customer's dipping machines, we suggest the following basic assembly method:

1. Fastening screw
2. Rubber gasket
3. Glove former
4. Rubber gasket
5. Metal mounting device
6. Air vent $\varnothing 3$

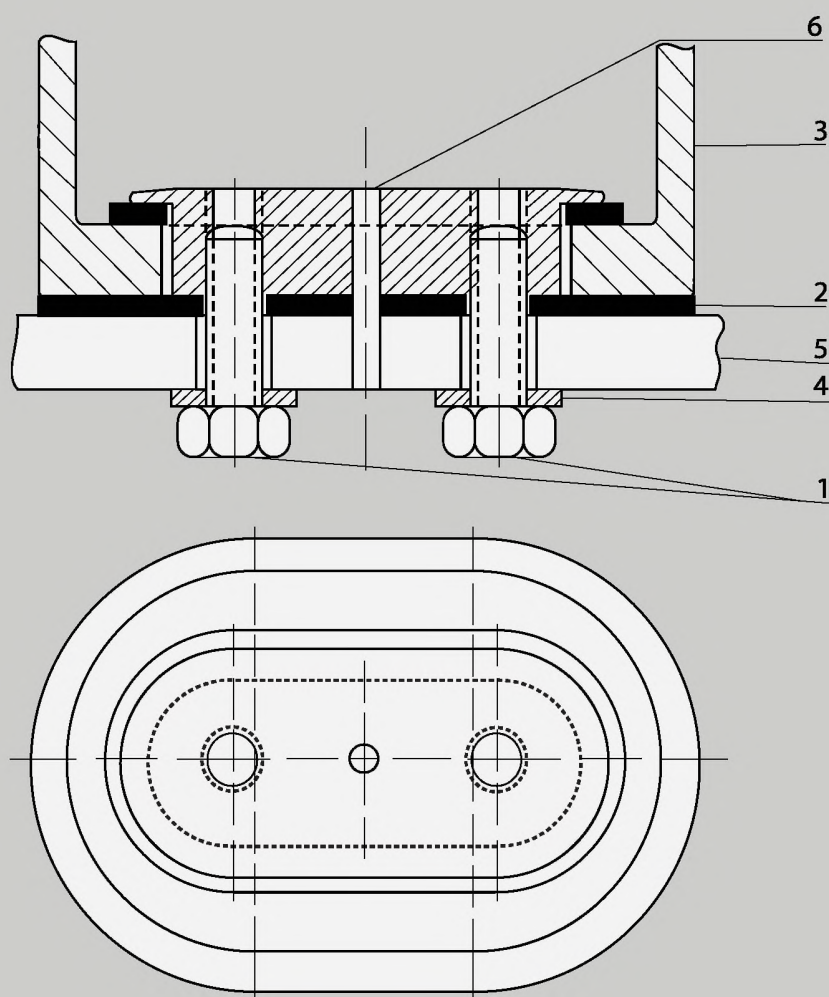

По вопросам продаж и поддержки обращайтесь:

Алматы (727)345-47-04
Ангарск (3955)60-70-56
Архангельск (8182)63-90-72
Астрахань (8512)99-46-04
Барнаул (3852)73-04-60
Белгород (4722)40-23-64
Благовещенск (4162)22-76-07
Брянск (4832)59-03-52
Владивосток (423)249-28-31
Владикавказ (8672)28-90-48
Владимир (4922)49-43-18
Волгоград (844)278-03-48
Вологда (8172)26-41-59
Воронеж (473)204-51-73
Екатеринбург (343)384-55-89

Иваново (4932)77-34-06
Ижевск (3412)26-03-58
Иркутск (395)279-98-46
Казань (843)206-01-48
Калининград (4012)72-03-81
Калуга (4842)92-23-67
Кемерово (3842)65-04-62
Киров (8332)68-02-04
Коломна (4966)23-41-49
Кострома (4942)77-07-48
Краснодар (861)203-40-90
Красноярск (391)204-63-61
Курск (4712)77-13-04
Курган (3522)50-90-47
Липецк (4742)52-20-81

Магнитогорск (3519)55-03-13
Москва (495)268-04-70
Мурманск (8152)59-64-93
Набережные Челны (8552)20-53-41
Новокузнецк (3843)20-46-81
Ноябрьск (3496)41-32-12
Новосибирск (383)227-86-73
Омск (3812)21-46-40
Орел (4862)44-53-42
Оренбург (3532)37-68-04
Пенза (8412)22-31-16
Петрозаводск (8142)55-98-37
Псков (8112)59-10-37
Пермь (342)205-81-47

Ростов-на-Дону (863)308-18-15
Рязань (4912)46-61-64
Самара (846)206-03-16
Санкт-Петербург (812)309-46-40
Саратов (845)249-38-78
Севастополь (8692)22-31-93
Саранск (8342)22-96-24
Симферополь (3652)67-13-56
Смоленск (4812)29-41-54
Сочи (862)225-72-31
Ставрополь (8652)20-65-13
Сургут (3462)77-98-35
Сыктывкар (8212)25-95-17
Тамбов (4752)50-40-97
Тверь (4822)63-31-35

Тольятти (8482)63-91-07
Томск (3822)98-41-53
Тула (4872)33-79-87
Тюмень (3452)66-21-18
Ульяновск (8422)24-23-59
Улан-Удэ (3012)59-97-51
Уфа (347)229-48-12
Хабаровск (4212)92-98-04
Чебоксары (8352)28-53-07
Челябинск (351)202-03-61
Череповец (8202)49-02-64
Чита (3022)38-34-83
Якутск (4112)23-90-97
Ярославль (4852)69-52-93

Россия +7(495)268-04-70

Казахстан +(727)345-47-04

Беларусь +(375)257-127-884

Узбекистан +998(71)205-18-59

Киргизия +996(312)96-26-47

эл.почта: cgc@nt-rt.ru || сайт: <https://ceramtec.nt-rt.ru>