

Фрезерные инструменты

Технические характеристики

По вопросам продаж и поддержки обращайтесь:

Алматы (727)345-47-04
Ангарск (3955)60-70-56
Архангельск (8182)63-90-72
Астрахань (8512)99-46-04
Барнаул (3852)73-04-60
Белгород (4722)40-23-64
Благовещенск (4162)22-76-07
Брянск (4832)59-03-52
Владивосток (423)249-28-31
Владикавказ (8672)28-90-48
Владимир (4922)49-43-18
Волгоград (844)278-03-48
Вологда (8172)26-41-59
Воронеж (473)204-51-73
Екатеринбург (343)384-55-89

Иваново (4932)77-34-06
Ижевск (3412)26-03-58
Иркутск (395)279-98-46
Казань (843)206-01-48
Калининград (4012)72-03-81
Калуга (4842)92-23-67
Кемерово (3842)65-04-62
Киров (8332)68-02-04
Коломна (4966)23-41-49
Кострома (4942)77-07-48
Краснодар (861)203-40-90
Красноярск (391)204-63-61
Курск (4712)77-13-04
Курган (3522)50-90-47
Липецк (4742)52-20-81

Магнитогорск (3519)55-03-13
Москва (495)268-04-70
Мурманск (8152)59-64-93
Набережные Челны (8552)20-53-41
Нижний Новгород (831)429-08-12
Новокузнецк (3843)20-46-81
Ноябрьск (3496)41-32-12
Новосибирск (383)227-86-73
Омск (3812)21-46-40
Орел (4862)44-53-42
Оренбург (3532)37-68-04
Пенза (8412)22-31-16
Петрозаводск (8142)55-98-37
Псков (8112)59-10-37
Пермь (342)205-81-47

Ростов-на-Дону (863)308-18-15
Рязань (4912)46-61-64
Самара (846)206-03-16
Санкт-Петербург (812)309-46-40
Саратов (845)249-38-78
Севастополь (8692)22-31-93
Саранск (8342)22-96-24
Симферополь (3652)67-13-56
Смоленск (4812)29-41-54
Сочи (862)225-72-31
Ставрополь (8652)20-65-13
Сургут (3462)77-98-35
Сыктывкар (8212)25-95-17
Тамбов (4752)50-40-97
Тверь (4822)63-31-35

Тольятти (8482)63-91-07
Томск (3822)98-41-53
Тула (4872)33-79-87
Тюмень (3452)66-21-18
Ульяновск (8422)24-23-59
Улан-Удэ (3012)59-97-51
Уфа (347)229-48-12
Хабаровск (4212)92-98-04
Чебоксары (8352)28-53-07
Челябинск (351)202-03-61
Череповец (8202)49-02-64
Чита (3022)38-34-83
Якутск (4112)23-90-97
Ярославль (4852)69-52-93

Россия +7(495)268-04-70

Казахстан +(727)345-47-04

Беларусь +(375)257-127-884

Узбекистан +998(71)205-18-59

Киргизия +996(312)96-26-47

эл.почта: cgc@nt-rt.ru || сайт: <https://ceramtec.nt-rt.ru>



Cutting materials for milling	6
Characteristics and application table for cutting materials for milling	7
Application area of cutting materials for milling	8
Engineered solution and application examples	9 - 11
SPK designation system for milling tools	12 - 13
Overview of milling tools and application areas	15 - 25
Milling tools for roughing	27 - 65
Milling tools for hard milling	30 - 33
Milling tools for tangential milling	50
Milling tools for high-feed, drill and circular milling	64
Milling tools for finish machining	66 - 83
Adjusting manual	85 - 93
Ceramic inserts for milling	96 - 108
PcBN inserts, full face laminated, for milling	110 - 113
PcBN inserts, solid, for milling	114 - 118
Cermet inserts for milling	120 - 125
Recommended cutting data	127 - 135
Application technology	137 - 155
Material comparison tables	156
Connection dimensions	158 - 158
Troubleshooting	159
Query form	160

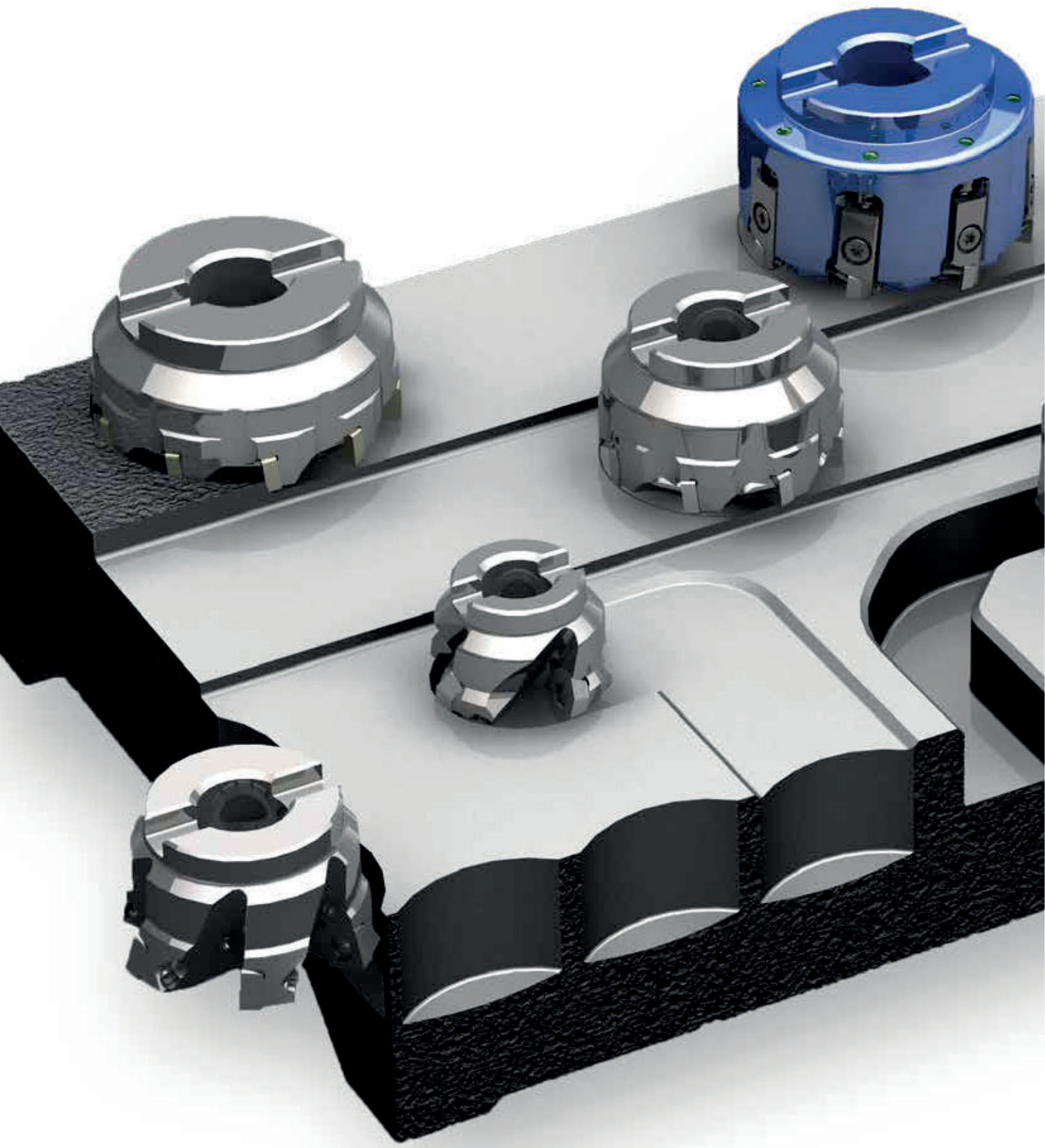

Cutting materials for milling

MIXED CERAMIC

Mixed ceramic is a composite of aluminum oxide and a hard titanium-based material with excellent wear resistance and edge stability even at high temperatures. The field of application of mixed ceramics in milling is in the finishing and fine finishing of cast iron workpieces.

SH 2 has an extremely homogeneous sub-micron structure. This causes an increased mechanical and thermal load capacity and allows a high-precision design of the cutting edges. This mixed-ceramic grade is thus ideal for finishing.

SILICON NITRIDE- AND SiAlON-CERAMIC

Milling places a wide range of demands on our cutting materials: high-speed milling, face milling with high variation in allowances, up to the milling of hard-to-machine cast iron grades. Our extensive range of cutting materials offers the optimum cutting material for a wide variety of milling tasks.

SL 500

The standard silicon nitride ceramic type demonstrates its strengths in a broad range of applications in the roughing and finishing of GJL (GG) materials, both in continuous and interrupted cuts.

SL 808

The optimized toughness and wear resistance of the SL 808 stands up to the longest milling paths in rough milling with high feed values per tooth for workpieces made of GJL (GG) and GJS (GGG).

LKM 840

Outstanding toughness combined with excellent wear resistance make this SiAlON ceramic a high-performance grade for the rough milling of GJL (GG), GJS (GGG) and HRSA (high-temperature super alloys)

materials. Its wear behavior enables the realization of large stock-removal rates while maintaining excellent process reliability.

SL 850 C

Coated silicon nitride ceramic with Al_2O_3 multilayer coating. It has high performance characteristics in the milling of GJS and Si-GJS materials.

SL 854 C

The TiN multilayer coating reduces wear and significantly reduces the friction between the cutting material and the tool material. This leads to longer tool life when milling GJL (GG) and GJS (GGG).

SL 858 C

The highest degree of toughness and wear resistance make the Al_2O_3 coated grade a milling specialist for the high-performance roughing and rough-finishing of GJL (GG) and GJS (GGG) parts.

PCBN

PcBN high-performance cutting materials enable the process-reliable HPC milling of cast iron workpieces. They set new standards with their excellent wear behavior in this respect. Their performance in terms of hot hardness, compressive strength and chemical stability is also absolutely impressive.

WBN 101

Its excellent toughness and its very good wear behavior enable high cutting values. It demonstrates its strengths in the rough-finishing and fine finishing of GJL (GG) workpieces.

WBN 115

Excellent thermal stability and the best toughness combined with high edge stability and excellent wear resistance result in a cutting material that is ideal for the roughing, finishing and fine-finishing of

GJL (GG) materials as well as for machining hardened cast iron.

WXM 845

This coated PcBN cutting material is used in hard milling. Its excellent edge stability and excellent toughness give the cutting material extraordinary wear resistance.

CERMET

Cermets are excellently suited for all machining operations where high surface quality and dimensional stability as well as tight tolerances must be observed. They guarantee a long tool life with small and medium chip cross sections and uniform allowances, and are ideal for the fine finishing and finishing of steel, sintered metal, and ductile cast iron.

SC 60

This variety demonstrates its strengths when it comes to the roughing-finishing of steel and cast iron materials, as it has a comparatively higher degree of toughness.

SC 7015

This coated milling grade is used in the finishing and fine-milling of GJS (GGG) as well as in construction and free-cutting steels.

Characteristics and application table for cutting materials for milling

	SPK-grade	ISO*	Material group				Machining type			Application area (DIN ISO 513)				
										01	10	20	30	40
Applications			P	K	H	S	T	M	G					
Mixed ceramic	SH 2	CM-K10	●	●	●		●	●	○					
Silicon nitride ceramic and SiAlON	SL 500	CN-K25-M		●			●	●	●					
	SL 808	CN-K30-M		●				●						
	LKM 840	CN-K25-M		●		●		●						
Coated	SL 850 C	CC-K30-M		●				●						
	SL 854 C	CC-K25-M		●				●						
	SL 858 C	CC-K30-M		●				●						
Cermet	SC 60	HT-P25-M	●	○				●						
	SC 7015	HC-P20	●	●				●						
PcBN	WBN 101	BH-K25		●			●	●	●					
	WBN 115	BH-K20		●	○		●	●	●					
	WXM 845	BC-H10-M		○	●			●						

*ISO: ISO application group

Material group:

P = Steel
 K = Cast iron
 H = Hard materials
 S = Super alloys
 (HRSA: heat-resistant super alloys)

Processing type:

T = Turning
 M = Milling
 G = Grooving

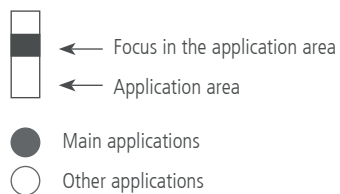

Application areas of cutting materials for milling

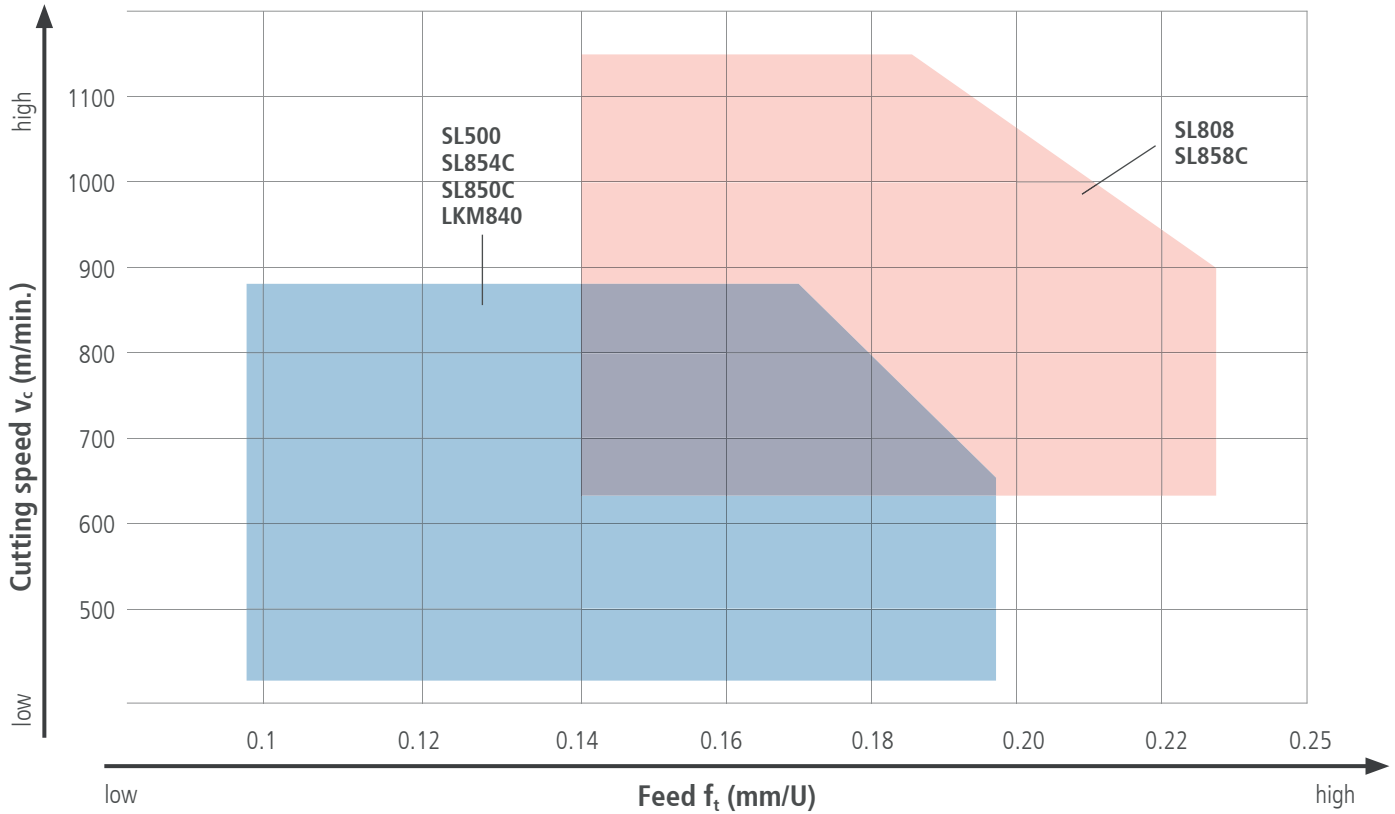
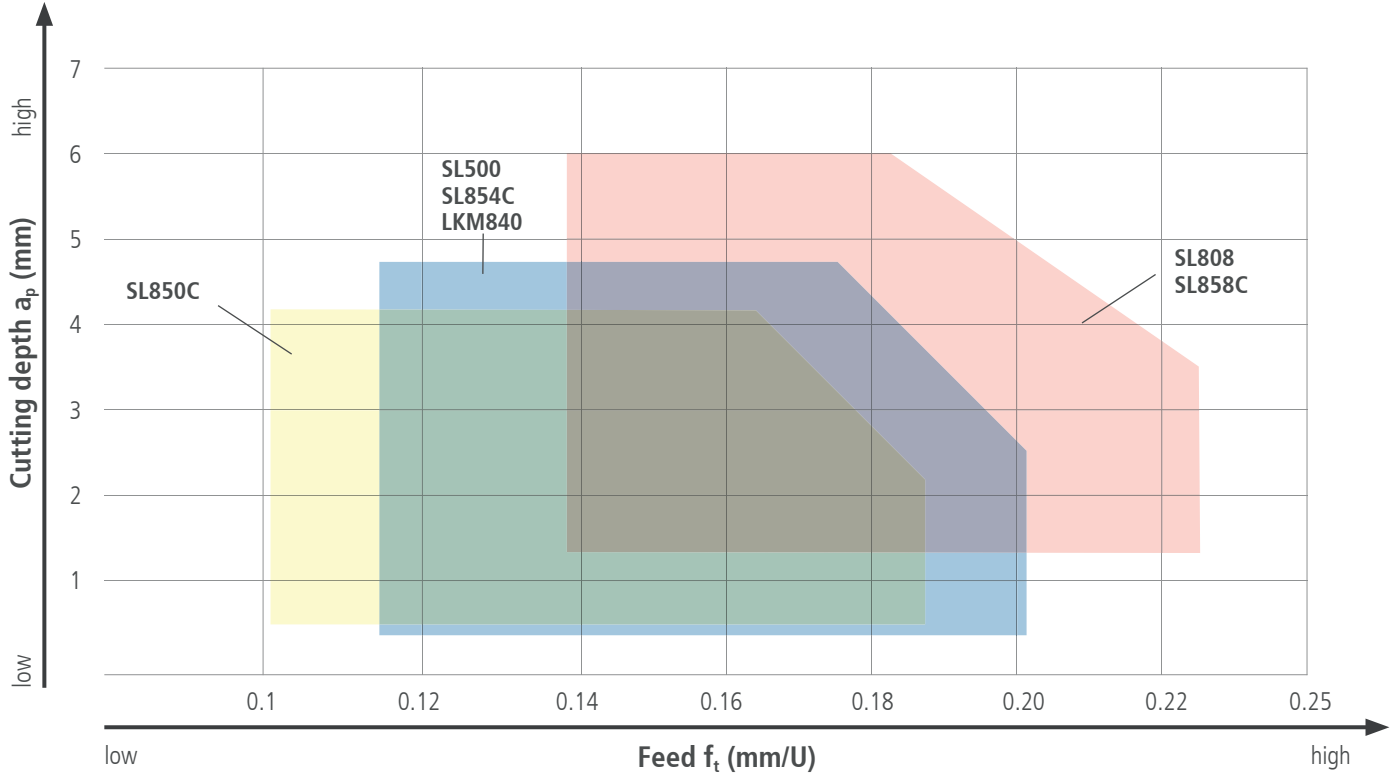

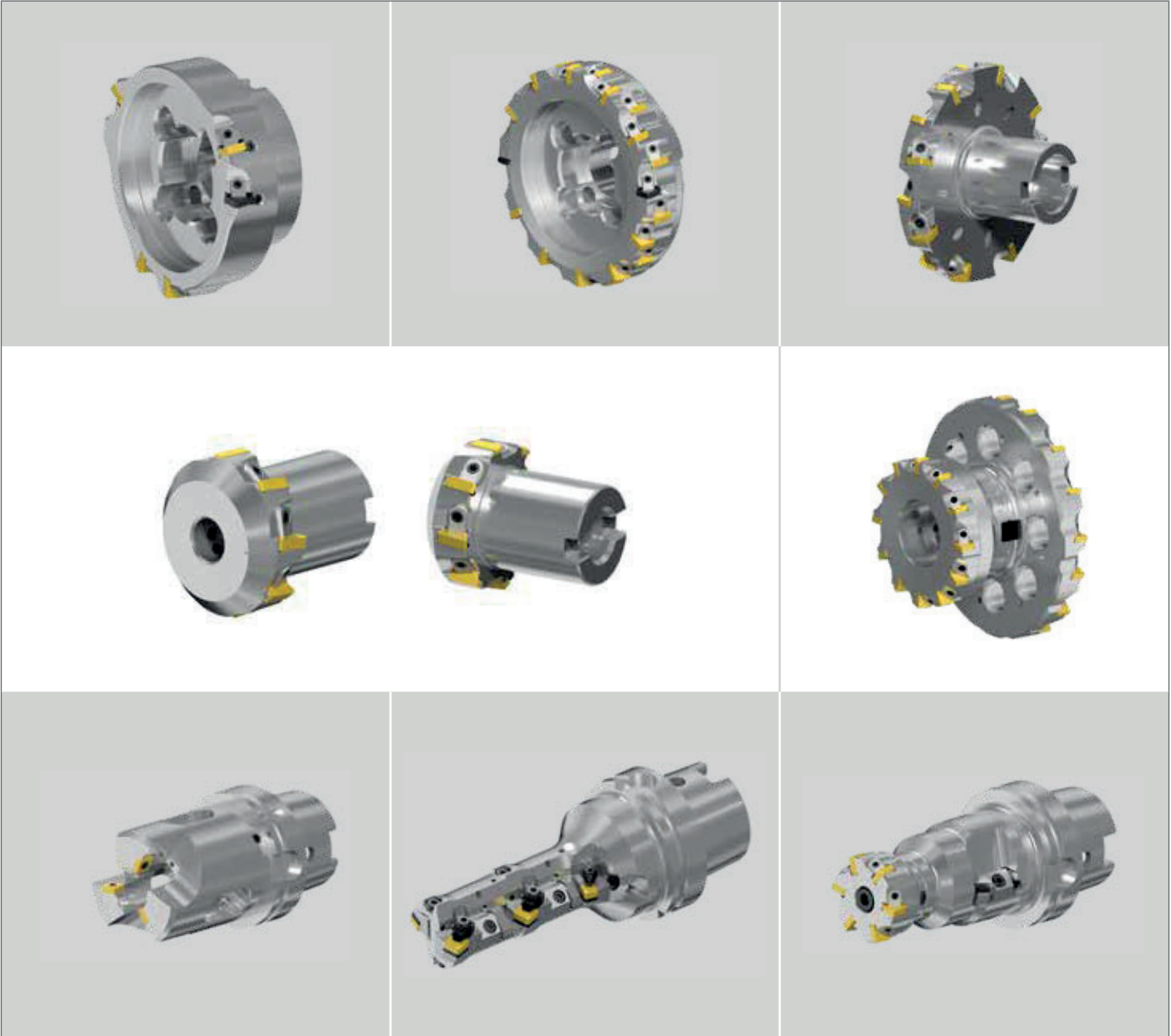

Machining examples

1) PFK-063-06TN1690R-AM
TNCN 160412
 $v_c = 800$ m/min
 $v_f = 4850$ mm/min
 $f_t = 0.19$ mm
 $a_p = 3 - 5$ mm

2) PFK-063-06SN1288R-AM
SNGN 120412
 $v_c = 800$ m/min
 $v_f = 4850$ mm/min
 $f_t = 0.19$ mm
 $a_p = 3$ mm

4) Boring tool
SNGX 150712
 $v_c = 650$ m/min
 $v_f = 3065$ mm/min
 $f_t = 0.4$ mm
 $a_p = 2 - 3$ mm

3) PFK-100-10HN1047R-AM
HNGX 100512
 $v_c = 800$ m/min
 $v_f = 5100$ mm/min
 $f_t = 0.2$ mm
 $a_p = 3$ mm

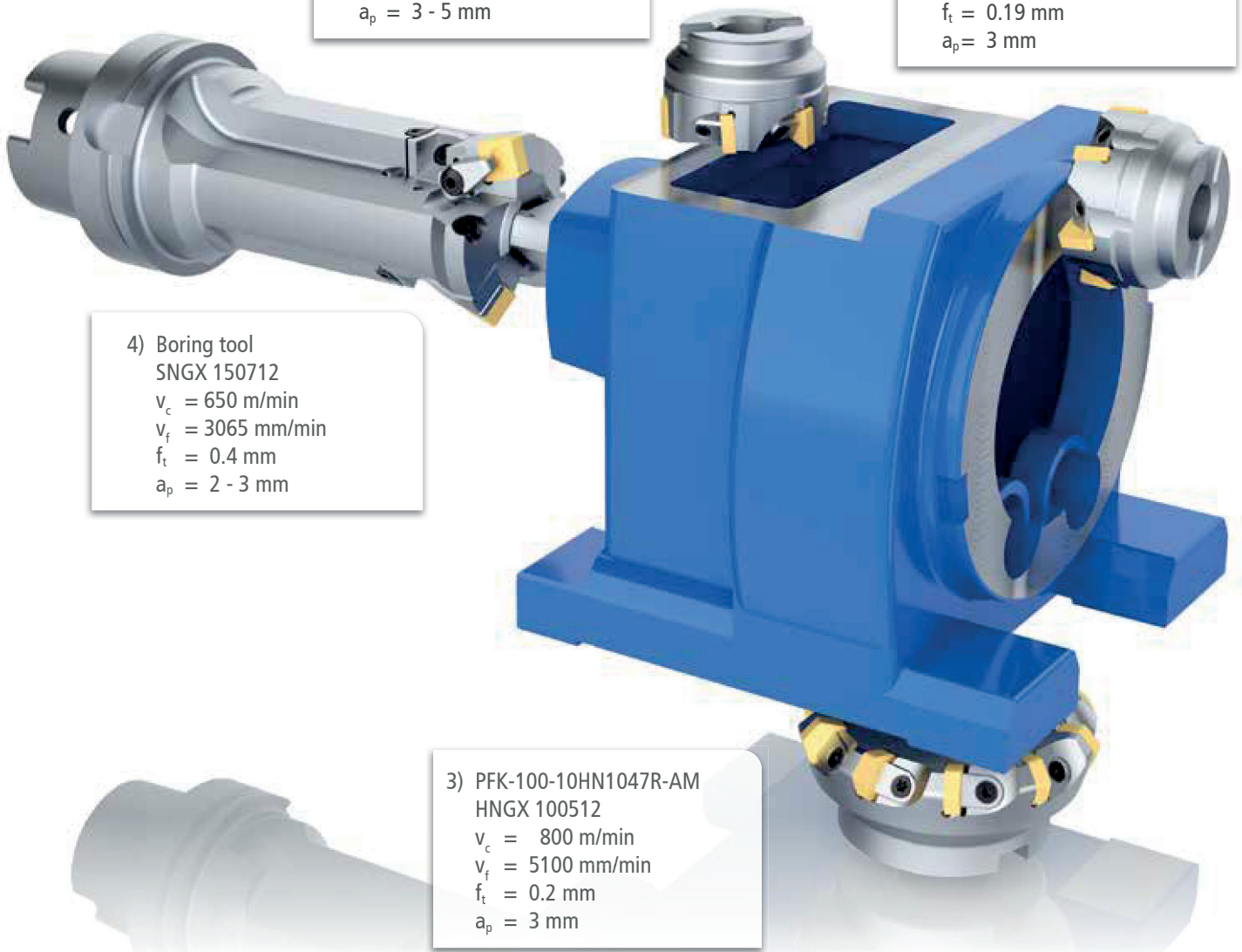



PUMP HOUSING

ROUGH MACHINING GJL-250

Milling cutter PFK-080-08HN1047R-AM
WSP: HNGX 100512 T01020 SL808

$V_c = 800$ m/min
 $V_f = 5100$ mm/min
 $f_t = 0.2$ mm
 $a_p = 2.0$ mm



HYDRAULIC BLOCK

ROUGH MACHINING GJS-400

Milling cutter PDK-125-12SN1288R-AM
WSP: SNGN 120408 T01020 SL858C

$V_c = 700$ m/min
 $V_f = 3850$ mm/min
 $f_t = 0.18$ mm
 $a_p = 2.5$ mm

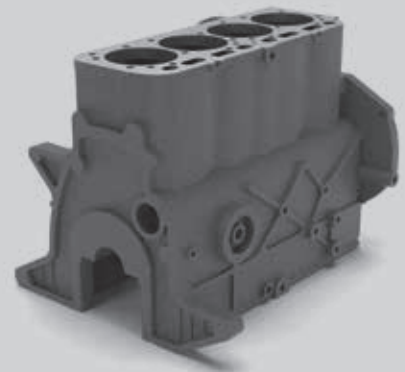

MOTOR BLOCK

FINISHING GJL-250

Milling cutter PPCM-250-18OP0543R-AM
WSP: OPHN 050412 T01020 SL500

2x OPHN 050412 T-S-8XR300W9 WBN 115
 $V_c = 900$ m/min
 $V_f = 3730$ mm/min
 $f_t = 0.18$ mm
 $a_p = 0.3$ mm

MANIFOLD

SiMo-CASTING ROUGH MACHINING

Milling cutter PFK-080-08SN1288R-AM
WSP: SNGN 120412 T01020 SL850C

$V_c = 650$ m/min
 $V_f = 2700$ mm/min
 $f_t = 0.13$ mm
 $a_p = 1.5$ mm



SPK designation system for milling tools

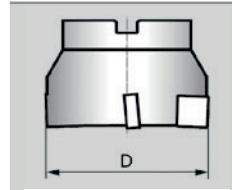

020	20 mm
025	25 mm
032	32 mm
...	...
063	63 mm
080	80 mm
100	100 mm
125	125 mm
...	...
315	315 mm
...	...

T	60°	
W	80°	
S	90°	
H	120°	
O	135°	
R	360°	

B	Circular / bore milling cutter
C	Contour milling cutter
E	Shoulder milling cutter
P	Face milling cutter
S	Disc milling cutter
T	Tangential milling cutter

C	Cartridge
K	Wedge clamping
L	Hole clamping
X	Special clamping

Tool type

Mounting type

Milling cutter diameter D

Insert shape

P **F** **L** **-** **080** **-** **08** **S**

Pocket details

F	All insert seats are fixed
E	All insert seats are adjustable
M	Insert seats are partially adjustable
D	Dual insert seat 90° adjustable 88° fixed
P	all insert seats are adjustable, with a prismatic guide-way

Version

-	Standard
S	Special milling cutter
M	Mixed assembly
I	Inch

Number of teeth t

01	1 tooth
02	2 teeth
03	3 teeth
04	4 teeth
...	...
28	28 teeth
...	...



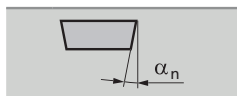
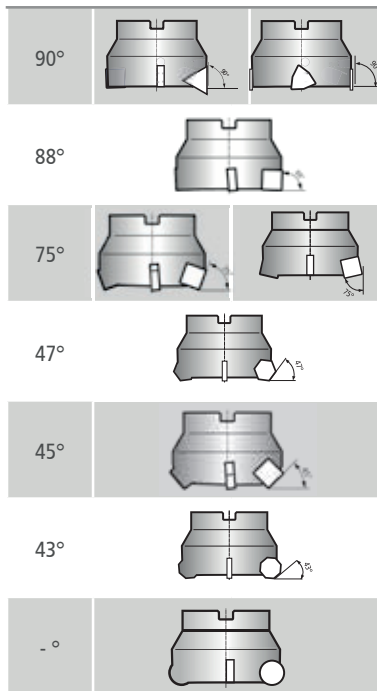

N	0°
C	7°
P	11°
D	15°
E	20°

Insert clearance angle α_n

Cutting edge angle κ_r

AM	Metric arbour milling cutters
AI	Inch arbour milling cutters
AJ	Japan inch arbour milling cutters
EM	Metric screw-on milling cutters
SM	Metric end milling cutters

Holder

P 13 88 R - AM

Insert size

H	O	R	S	T	W
10 16.2	05 13.5	06 6.35	09 9.52	06 3.97	09 13.5
	06 16.5	09 9.52	12 12.7	09 5.56	
		12 12.07	13 13.5	11 6.35	
			15 15.88	16 9.52	
			16 16.5	22 12.70	
			19 19.05	27 15.88	
				33 19.05	

Rotational direction of milling cutter

L	Left
R	Right







Special design

	None
CL	Cutting edge interior cooling
CV	Cooling with distributor cap

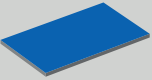
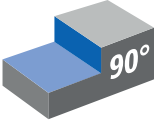
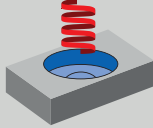
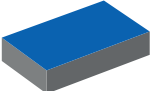
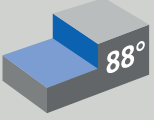
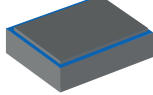
F)

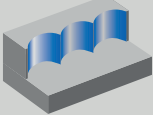
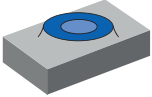

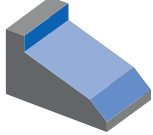
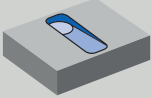







Overview of application areas

 Face-finish milling	 Shoulder milling 90°	 Helical milling
 Face-rough milling	 Shoulder milling 88°	 Trimming
 Slot milling	 High-feed milling	 Plunge milling
 Sprue milling	 Milling of heat-resistant alloys	 Milling of angular shoulders and chamfers
 Ramp milling	 Hard milling	

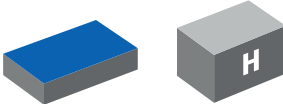
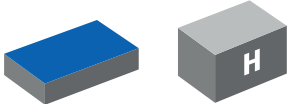
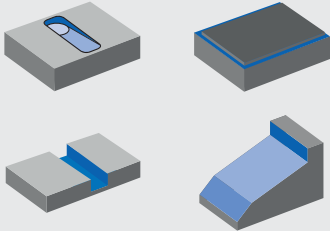
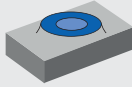
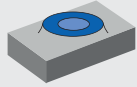







Overview of milling tools and application areas

ROUGH MILLING

			
Milling cutter type	PFKRP	PFKRP12	PFKRN
Page	28	30	32
Materials	K S	K H	K H
Surface quality	6.3/▽	6.3/▽	6.3/▽
Ø-range	20 - 40 mm*	50 - 100 mm*	50 - 100 mm*
a _p	0.3 - 4.0 mm	0.5 - 2.0 mm	0.5 - 2.0 mm
Cutting edge angle	-	-	-
Main applications			
Further applications			
Cutting inserts			
Adjustable insert seats	X	X	X

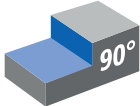
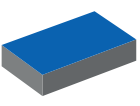
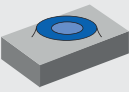
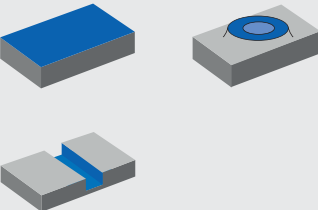



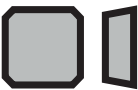

Overview of milling tools and application areas

ROUGH MILLING

			
Milling cutter type	PFKSRN	PFK90TN	PFK88SD
Page	34	36	38
Materials	K S	K S P	K S P
Surface quality	6.3/√	12.5/√ 6.3/√	12.5/√ 6.3/√
Ø-range	50 - 100 mm*	50 - 160 mm*	50 - 125 mm*
a _p	0.5 - 5.0 mm	0.5 - 1.0 mm	up to 6.0 mm
Cutting edge angle	-	90°	88°
Main applications			
Further applications			
Cutting inserts			
Adjustable insert seats	X	X	X

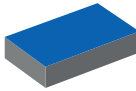
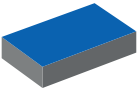
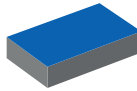
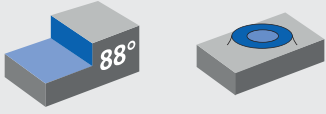
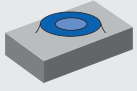
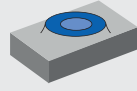





Overview of milling tools and application areas

ROUGH MILLING

			
Milling cutter type	PFK88SN	PFK75SN	PFK45SN
Page	40	42	44
Materials	K S P	K S P	K S P
Surface quality	12.5/ 6.3/	12.5/ 6.3/	12.5/ 6.3/
Ø-range	40 - 160 mm*	50 - 160 mm*	50 - 160 mm*
a _p	up to 6.0 mm	up to 6.0 mm	up to 5.0 mm
Cutting edge angle	88°	75°	45°
Main applications			
Further applications			
Cutting inserts			
Adjustable insert seats	X	X	X

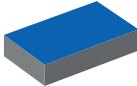
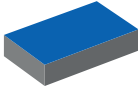
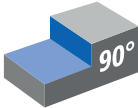
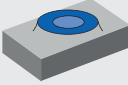
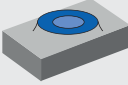





Overview of milling tools and application areas

ROUGH MILLING

			
Milling cutter type	PFK47HD	PFK47HN	TFL90WP
Page	46	48	50
Materials	K S P	K S P	K
Surface quality	12.5/ 6.3/	12.5/ 6.3/	6.3/
Ø-range	80 - 160 mm*	80 - 160 mm*	63 - 160 mm*
a _p	up to 5.5 mm	up to 5.0 mm	up to 5.0 mm
Cutting edge angle	47°	47°	90°
Main applications			
Further applications			
Cutting inserts			
Adjustable insert seats	X	X	X

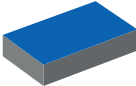
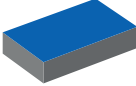
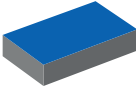
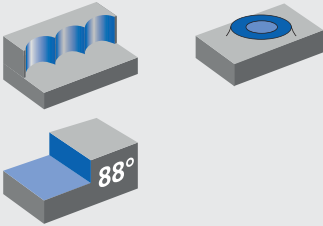
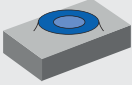
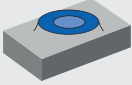





Overview of milling tools and application areas

ROUGH MILLING

			
Milling cutter type	PFL88SP	PFL75SP	PFL45SP
Page	52	54	56
Materials	K S		K S
Surface quality	12.5/ 6.3/	12.5/ 6.3/	12.5/ 6.3/
Ø-range	63 - 200 mm*	50 - 200 mm*	50 - 200 mm*
a _p	up to 5.0 mm	up to 5.0 mm	up to 5.0 mm
Cutting edge angle	88°	75°	45°
Main applications			
Further applications			
Cutting inserts			
Adjustable insert seats	X	X	X

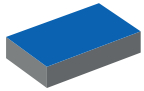
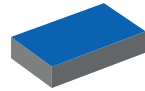
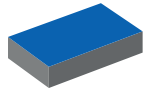
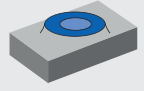
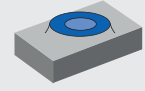
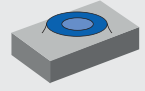



Overview of milling tools and application areas

ROUGH MILLING

			
Milling cutter type	PFL43OP	PFL43OE	PFL43ON
Page	58	60	62
Materials	K S	K S	K S
Surface quality	12.5/ 6.3/	12.5/ 6.3/	12.5/ 6.3/
Ø-range	50 - 200 mm*	50 - 200 mm*	63 - 160 mm*
a _p	up to 4.0 mm	up to 4.0 mm	up to 4.0 mm
Cutting edge angle	43°	43°	43°
Main applications			
Further applications			
Cutting inserts			
Adjustable insert seats	X	X	X



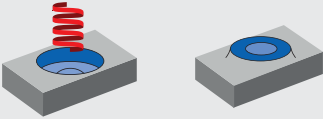



Overview of milling tools and application areas

ROUGH MILLING

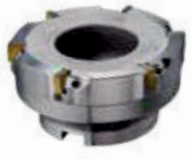
	
Milling cutter type	BFL75SX
Page	64
Materials	K S
Surface quality	12.5 / 6.3
Ø-range	63 - 100 mm*
a _p	up to 2.0 mm
Cutting edge angle	-
Main applications	
Further applications	
Cutting inserts	
Adjustable insert seats	X

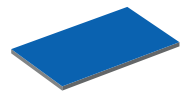
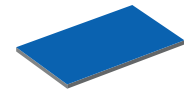
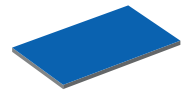
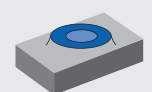
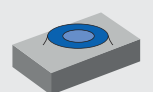
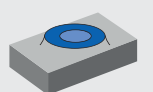







Overview of milling tools and application areas

FINISH MILLING

			
Milling cutter type	PMK88SN	PMKS88SN	PDK88SN
Page	66	68	70
Materials	K S P	K S P	K S P
Surface quality	6.3 / 3.2 / 0.8	6.3 / 3.2 / 0.8	3.2 / 0.8
Ø-range	63 - 250 mm*	63 - 160 mm*	63 - 250 mm*
a _p	0.5 - 1.0 mm	0.5 - 1.0 mm	0.5 - 1.0 mm
Cutting edge angle	88°	88°	88°
Main applications			
Further applications			
Cutting inserts			
Adjustable insert seats	✓	✓	✓

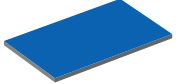
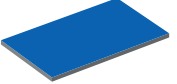
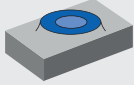
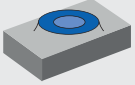
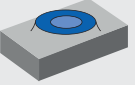





Overview of milling tools and application areas

FINISH MILLING

			
Milling cutter type	PEK88SN	PMC43OP	PMCM43OP
Page	72	74	76
Materials	K S P	K S P	K S P
Surface quality	6.3 / 3.2 / 0.8 / ∇	3.2 / 1.6 / ∇	3.2 / 0.8 / ∇
\varnothing -range	50 - 250 mm*	100 - 250 mm*	100 - 250 mm*
a_p	0.5 - 1.0 mm	0.2 - 0.8 mm	0.2 - 0.8 mm
Cutting edge angle	88°	43°	43°/90°
Main applications			
Further applications			
Cutting inserts			
Adjustable insert seats	✓	✓	✓

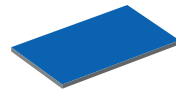
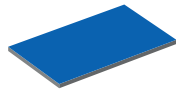
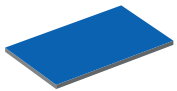
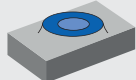
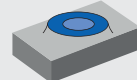
Overview of milling tools and application areas

FINISH MILLING

			
Milling cutter type	PPC88SP	PPCM88SP	MFS88SN
Page	78	80	82
Materials	K S	K S	K S P
Surface quality	3.2/ 0.8/	3.2/ 0.5/	6.3/ 3.2/ 0.8/
Ø-range	80 - 315 mm*	80 - 315 mm*	80 - 250 mm*
a _p	0.2 - 0.8 mm	0.2 - 0.8 mm	0.1 - 1.0 mm
Cutting edge angle	88°	88° / 90°	88°
Main applications			
Further applications			
Cutting inserts			
Adjustable insert seats	✓	✓	✓



Screw-on milling cutter

PFKRP

Rough milling

6.3
▽



stable / unstable components

$v_c = 500 - 1200 \text{ m/min}$

$f_t = 0.15 - 0.30 \text{ mm}$

a_p for $\varnothing 20 \text{ mm} = 0.3 - 2.5 \text{ mm}$

a_p for $\varnothing \geq 25 \text{ mm} = 0.3 - 4.0 \text{ mm}$

Axial rake angle $\gamma_s = +5^\circ$
Radial rake angle $\gamma_r = -5^\circ$

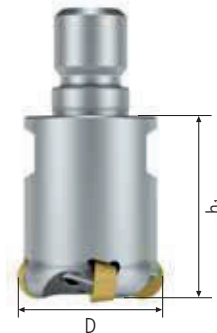
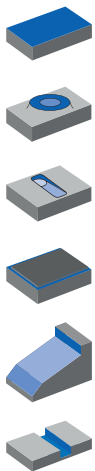

Type	SPK order no.	Dimensions				
		D	z	d ₄	h ₁	n _{max} (rpm)
PFK-020-03RP0600R-EMCL	771.30.000.51	20	3	-	30	30000
PFK-025-03RP0900R-EMCL	771.30.000.61	25	3	-	35	23000
PFK-032-04RP0900R-EMCL	771.30.000.71	32	4	-	40	23000
PFK-040-05RP0900R-EMCL	771.30.000.81	40	5	-	40	8000

For PFK RP milling cutter with $\varnothing = 20 \text{ mm}$



For PEK RP milling cutter with $\varnothing = 25 - 40 \text{ mm}$

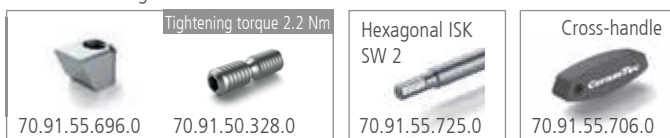

Indexable inserts for **PFKRP**

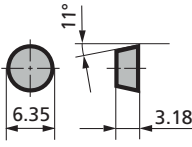
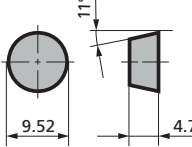
INSERT	TYPE	GRADE	K													H	S	P	SPK ORDER NR.											
			GJL			GJS				ADI		SI GJS		GJV																
			EN-GJL 150	EN-GJL 200	EN-GJL 250	EN-GJL 300	EN-GJL 350	EN-GJS 400-15	EN-GJS 500-7	EN-GJS 600-3	EN-GJS 700-2	EN-GJS 800-2	EN-GJS 800-8	EN-GJS 1000-5	EN-GJS 1200-2	EN-GJS 1400-0	EN-GJS 450-18	EN-GJS 500-14	EN-GJS 600-10	EN-GJV 300	EN-GJV 350	EN-GJV 400	EN-GJV 450	EN-GJV 500	HARD STEEL	CHILLED CAST IRON	DIE CASTING	HSRA	STEEL	
RPGN 06 03 T00520 	RPGN 06 03 00 T00520	LKM 840	◆	◆	◆	◆	◆	◆	◆	◆	◆						◇	◇											◆	
RPGN 09 04 T00520 	RPGN 09 04 00 T00520	LKM 840	◆	◆	◆	◆	◆	◆	◆	◆	◆						◇	◇											◆	

ISO application group

K ■ Cast iron

H ■ Hard materials

S ■ HSRA

P ■ Steel

Main application ◆

Secondary application ◇

Face-milling cutter **PFKRP12**

Hard milling

6.3
▽



stable components

$v_c = 150 - 300 \text{ m/min}$
 $f_t = 0.15 - 0.30 \text{ mm}$
 $a_p = 0.50 - 2 \text{ mm}$

Axial rake angle $\gamma_a = 5^\circ$
Radial rake angle $\gamma_r = -5^\circ$
Connection dimensions as per DIN 8030

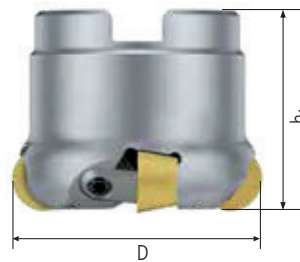

Type	SPK order no.	Dimensions				
		D	Z	d ₄	h ₁	n _{max} (rpm)
PFK-050-05RP1200R-AM	771.00.167.21	50	5	-	40	18000
PFK-063-06RP1200R-AM	771.00.167.31	63	6	-	40	13000
PFK-080-08RP1200R-AM	771.00.167.41	80	8	-	50	10000
PFK-100-10RP1200R-AM	771.00.167.51	100	10	-	50	8000

For PFK RN milling cutter with $\varnothing = 50 \text{ mm}$



For PFK RN milling cutter with $\varnothing = 63 - 100 \text{ mm}$

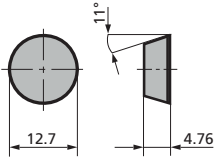

Indexable inserts for **PFKRP**

INSERT	TYPE	GRADE	K													H	S	P	SPK ORDER NR.						
			GJL				GJS				ADI	SI GJS		GJV											
	RPCN 120400 S01025	WXM 845	◆	◆	◆	◆													◆	◆				44.80.060.46.1	
		WXM 848	◆	◆	◆	◆														◆	◆	◆			44.80.060.46.9

ISO application group

K ■ Cast iron

H ■ Hard materials

S ■ HSRA

P ■ Steel

Main application ◆

Secondary application ◆

Face-milling cutter **PFKRN**

Hard milling

6.3
▽



stable components

$v_c = 150 - 300 \text{ m/min}$
 $f_t = 0.15 - 0.30 \text{ mm}$
 $a_p = 0.50 - 2 \text{ mm}$

Axial rake angle $\gamma_a = -6^\circ$
Radial rake angle $\gamma_r = -12^\circ$
Connection dimensions as per DIN 8030

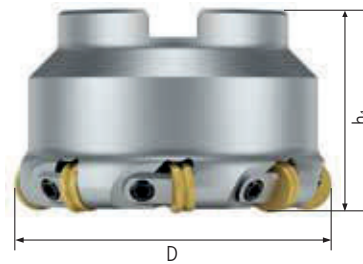

Type	SPK order no.	Dimensions				
		D	Z	d ₄	h ₁	n _{max} (rpm)
PFK-050-05RN1200R-AM	771.00.069.21	50	5	-	40	18000
PFK-063-06RN1200R-AM	771.00.069.31	63	6	-	40	13000
PFK-080-08RN1200R-AM	771.00.069.41	80	8	-	50	10000
PFK-100-10RN1200R-AM	771.00.069.51	100	10	-	50	8000

For PFK RN milling cutter with $\varnothing = 50 \text{ mm}$



For PFK RN milling cutter with $\varnothing = 63 - 100 \text{ mm}$

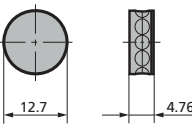

Indexable inserts for **PFKRN**

INSERT	TYPE	GRADE	K													H	S	P	SPK ORDER NR.											
			GJL			GJS			ADI		SI GJS		GJV																	
			EN-GJL 150	EN-GJL 200	EN-GJL 250	EN-GJL 300	EN-GJL 350	EN-GJS 400-15	EN-GJS 500-7	EN-GJS 600-3	EN-GJS 700-2	EN-GJS 800-2	EN-GJS 800-8	EN-GJS 1000-5	EN-GJS 1200-2	EN-GJS 1400-0	EN-GJS 450-18	EN-GJS 500-14	EN-GJS 600-10	EN-GJV 300	EN-GJV 350	EN-GJV 400	EN-GJV 450	EN-GJV 500	HARD STEEL	CHILLED CAST IRON	DIE CASTING	HSRA	STEEL	
RNCX 1204 .. S 	RNCX 120400 S01025	WXM 845	◆	◆	◆	◆	◆																		◆	◆	◆			14.48.057.46.1
		WXM 848	◆	◆	◆	◆	◆																			◆	◆	◆		

ISO application group

K ■ Cast iron

H ■ Hard materials

S ■ HSRA

P ■ Steel

Main application ◆

Secondary application ◆

Face-milling cutter **PFKSRN**

Rough milling

6.3
▽



stable components

$v_c = 500 - 1200 \text{ m/min}$
 $f_t = 0.15 - 0.30 \text{ mm}$
 $a_p = 0.50 - 5 \text{ mm}$

Axial rake angle $\gamma_a = -6^\circ$
Radial rake angle $\gamma_r = -12^\circ$
Connection dimensions as per DIN 8030

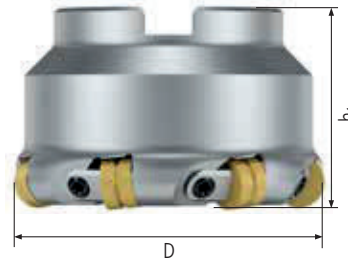

Type	SPK order no.	Dimensions				
		D	Z	d ₄	h ₁	n _{max} (rpm)
PFKS-050-04RN1200R-AM	771.00.068.21	50	4	-	40	18000
PFKS-063-05RN1200R-AM	771.00.068.31	63	5	-	40	13000
PFKS-080-07RN1200R-AM	771.00.068.41	80	7	-	50	10000
PFKS-100-09RN1200R-AM	771.00.068.51	100	9	-	50	8000

For PFKS RN milling cutter with $\varnothing = 50 \text{ mm}$



For PFKS RN milling cutter with $\varnothing = 63 - 100 \text{ mm}$

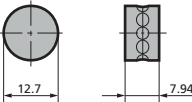

Indexable inserts for **PFKSRN**

INSERT	TYPE	GRADE	K													H	S	P	SPK ORDER NR.											
			GJL			GJS			ADI		SI GJS		GJV																	
			EN-GJL 150	EN-GJL 200	EN-GJL 250	EN-GJL 300	EN-GJL 350	EN-GJS 400-15	EN-GJS 500-7	EN-GJS 600-3	EN-GJS 700-2	EN-GJS 800-2	EN-GJS 800-8	EN-GJS 1000-5	EN-GJS 1200-2	EN-GJS 1400-0	EN-GJS 450-18	EN-GJS 500-14	EN-GJS 600-10	EN-GJV 300	EN-GJV 350	EN-GJV 400	EN-GJV 450	EN-GJV 500	HARD STEEL	CHILLED CAST IRON	DIE CASTING	HRSA	STEEL	
RNCX 1207 .. T 	RNCX 120700 T01020	SL 808	◆	◆	◆	◆	◆	◆	◆	◆	◆					◆	◆	◆	◆	◆	◆	◆	◆				◆			17.40.196.20.1
		LKM 840	◆	◆	◆	◆	◆	◆	◆	◆	◆	◆					◆	◆	◆	◆	◆	◆	◆	◆				◆		

ISO application group

K ■ Cast iron

H ■ Hard materials

S ■ HSRA

P ■ Steel

Main application ◆

Secondary application ◆

Face-milling cutter **PFK90TN**

Rough milling

12.5
6.3



stable / unstable components

$v_c = 600 - 1000 \text{ m/min}$
 $f_t = 0.16 - 0.30 \text{ mm}$
 $a_p = \text{up to } 6.0 \text{ mm}$

Axial rake angle $\gamma_a = -6^\circ$
Radial rake angle $\gamma_r = -10^\circ$
Connection dimensions as per DIN 8030

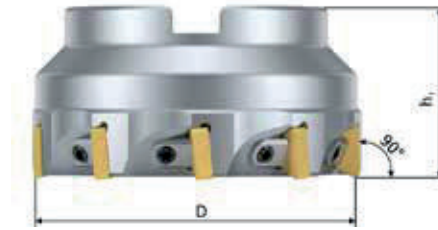
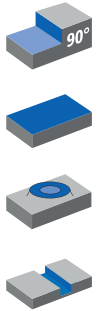

Type	SPK order no.	Dimensions				
		D	Z	d ₄	h ₁	n _{max} (rpm)
PFK-050-05TN1690R-AM	771.00.042.23	50	5	-	40	18000
PFK-063-06TN1690R-AM	771.00.042.33	63	6	-	40	13000
PFK-080-08TN1690R-AM	771.00.042.43	80	8	-	50	10000
PFK-100-10TN1690R-AM	771.00.042.53	100	10	-	50	8000
PFK-125-12TN1690R-AM	771.00.042.63	125	12	-	63	6000
PFK-160-16TN1690R-AM	771.00.042.73	160	16	-	63	5000

For PFK90TN milling cutter with $\varnothing = 50 \text{ mm}$

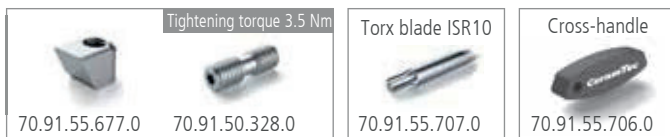

For PFK90TN milling cutter with $\varnothing = 63 - 160 \text{ mm}$

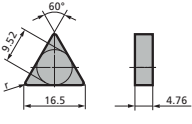
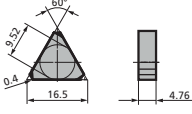

Indexable inserts for **PFK90TN**

INSERT	TYPE	GRADE	K														H	S	P	SPK ORDER NR.									
			GJL			GJS				ADI		SI GJS		GJV			HARD STEEL	CHILLED CAST IRON	DIE CASTING		HSRA	STEEL							
			EN-GJL 150	EN-GJL 200	EN-GJL 250	EN-GJL 300	EN-GJL 350	EN-GJS 400-15	EN-GJS 500-7	EN-GJS 600-3	EN-GJS 700-2	EN-GJS 800-2	EN-GJS 800-8	EN-GJS 1000-5	EN-GJS 1200-2	EN-GJS 1400-0				EN-GJS 450-18			EN-GJS 500-14	EN-GJS 600-10	EN-GJV 300	EN-GJV 350	EN-GJV 400	EN-GJV 450	EN-GJV 500
TNCN 1604 .. T 	TNCN 160404 T01020	SL 808	◆	◆	◆	◆	◆	◆	◆	◆	◆	◆	◆	◆	◆	◆	◆	◆	◆										17.30.190.20.1
		SL 854 C	◆	◆	◆	◆	◆	◆	◆	◆	◆	◆	◆	◆	◆	◆	◆	◆	◆	◆	◆	◆	◆	◆	◆	◆	◆	◆	17.30.190.20.9
	TNCN 160408 T01020	SL 808	◆	◆	◆	◆	◆	◆	◆	◆	◆	◆	◆			◆	◆	◆	◆									17.30.191.20.1	
		SL 854 C	◆	◆	◆	◆	◆	◆	◆	◆	◆	◆	◆	◆	◆	◆	◆	◆	◆	◆	◆	◆	◆	◆	◆	◆	◆	◆	17.30.191.20.9
	TNCN 160412 T01020	SL 808	◆	◆	◆	◆	◆	◆	◆	◆	◆	◆	◆				◆	◆	◆										17.30.192.20.1
		SL 854 C	◆	◆	◆	◆	◆	◆	◆	◆	◆	◆	◆	◆	◆	◆	◆	◆	◆	◆	◆	◆	◆	◆	◆	◆	◆	◆	17.30.192.20.9
TNCN 1604 PC T 	TNCN 1604 PC T	SL 808	◆	◆	◆	◆	◆	◆	◆	◆	◆	◆				◆	◆	◆										17.30.189.20.1	

ISO application group

K ■ Cast iron

H ■ Hard materials

S ■ HSRA

P ■ Steel

Main application ◆

Secondary application ◆

Face-milling cutter

PFK88SD

Rough milling

12.5
6.3



stable / unstable components

$v_c = 600 - 1200 \text{ m/min}$
 $f_t = 0.14 - 0.30 \text{ mm}$
 $a_p = \text{up to } 6 \text{ mm}$

Axial rake angle $\gamma_a = +7^\circ$
 Radial rake angle $\gamma_r = +3^\circ$
 Connection dimensions as per DIN 8030

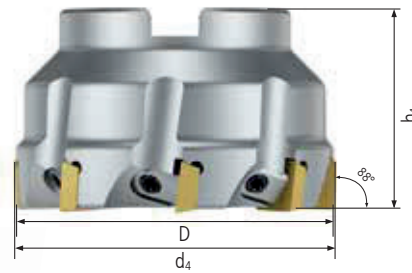
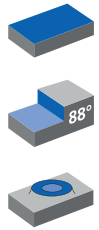

Type	SPK order no.	Dimensions				
		D	Z	d ₄	h ₁	n _{max} (rpm)
PFK-050-05SD1288R-AM	771.00.013.22	50	5	51	40	18000
PFK-063-06SD1288R-AM	771.00.013.32	63	6	64	40	13000
PFK-080-08SD1288R-AM	771.00.013.42	80	8	81	50	10000
PFK-100-10SD1288R-AM	771.00.013.52	100	10	101	50	8000
PFK-125-12SD1288R-AM	771.00.013.62	125	12	126	63	8000

 Tightening torque 3.5 Nm 70.91.55.547.0	 70.91.50.354.0	 Torx blade ISR15 70.91.55.708.0	 Cross-handle 70.91.55.706.0
---	---	---	---

Indexable inserts for **PFK88SD**

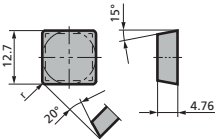
INSERT	TYPE	GRADE	K													H	S	P	SPK ORDER NR.												
			GJL			GJS			ADI		SI GJS		GJV																		
			EN-GJL 150	EN-GJL 200	EN-GJL 250	EN-GJL 300	EN-GJL 350	EN-GJS 400-15	EN-GJS 500-7	EN-GJS 600-3	EN-GJS 700-2	EN-GJS 800-2	EN-GJS 800-8	EN-GJS 1000-5	EN-GJS 1200-2	EN-GJS 1400-0	EN-GJS 450-18	EN-GJS 500-14	EN-GJS 600-10	EN-GJV 300	EN-GJV 350	EN-GJV 400	EN-GJV 450	EN-GJV 500	HARD STEEL	CHILLED CAST IRON	DIE CASTING	HSRA	STEEL		
	SDCN 120408 T01020	SL 500	◆	◆	◆	◆	◆										◇	◇													36.12.340.20.0
		SL 808	◆	◆	◆	◆	◆	◇	◆	◆	◆	◇																			17.12.340.20.0
	SDCN 120412 T01020	SL 500	◆	◆	◆	◆	◆										◇	◇	◇												36.12.341.20.0
		SL 808	◆	◆	◆	◆	◆	◇	◆	◆	◆	◇																			17.12.341.20.0

ISO application group

K ■ Cast iron

H ■ Hard materials

S ■ HSRA

P ■ Steel

Main application ◆

Secondary application ◇

Face-milling cutter **PFK88SN**

Rough milling

12.5
6.3



stable components

$v_c = 600 - 1200 \text{ m/min}$
 $f_t = 0.14 - 0.30 \text{ mm}$
 $a_p = \text{up to } 6 \text{ mm}$

Axial rake angle $\gamma_s = -6^\circ$
Radial rake angle γ_r depending on $\phi = -7^\circ$ to -12°
Connection dimensions as per DIN 8030

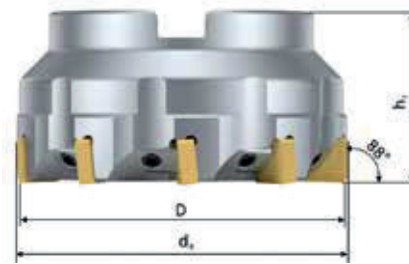
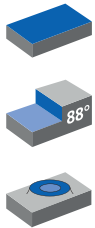

Type	SPK order no.	Dimensions				
		D	Z	d ₄	h ₁	n _{max} (rpm)
PFK-040-04SN0988R-AM	771.00.030.12	40	4	41	40	23000
PFK-050-05SN1288R-AM	771.00.030.22	50	5	51	40	18000
PFK-063-06SN1288R-AM	771.00.030.32	63	6	64	40	13000
PFK-080-08SN1288R-AM	771.00.030.42	80	8	81	50	10000
PFK-100-10SN1288R-AM	771.00.030.52	100	10	101	50	8000
PFK-125-12SN1288R-AM	771.00.030.62	125	12	126	63	8000
PFK-160-15SN1288R-AM	771.00.030.72	160	15	161	63	6000

For PFK88SN milling cutter with $\phi = 40 - 50 \text{ mm}$



For PFK88SN milling cutter with $\phi = 63 - 160 \text{ mm}$



Indexable inserts for **PFK88SN**

INSERT	TYPE	GRADE	K													H	S	P	SPK ORDER NR.																		
			GJL			GJS			ADI		SI GJS		GJV			HARD STEEL CHILLED CAST IRON DIE CASTING	HRSA	STEEL																			
			EN-GJL 150	EN-GJL 200	EN-GJL 250	EN-GJL 300	EN-GJL 350	EN-GJS 400-15	EN-GJS 500-7	EN-GJS 500-3	EN-GJS 700-2	EN-GJS 800-2	EN-GJS 800-8	EN-GJS 1000-5	EN-GJS 1200-2					EN-GJS 1400-0	EN-GJS 450-18	EN-GJS 500-14	EN-GJS 600-10	EN-GJV 300	EN-GJV 350	EN-GJV 400	EN-GJV 450	EN-GJV 500									
SNCN 0904 .. T 	SNCN 090404 T00520	SL 808	◆	◆	◆	◆	◆	◆	◆	◆	◆	◆	◆	◆	◆	◆	◆	◆																			17.10.454.03.1
SNCN 0904 ZN T 	SNCN 0904 ZN T00520	SL 500	◆	◆	◆	◆	◆	◆	◆	◆	◆	◆	◆	◆	◆	◆	◆	◆																	36.10.445.03.0		
		SL 808	◆	◆	◆	◆	◆	◆	◆	◆	◆	◆	◆	◆	◆	◆	◆	◆	◆																17.10.445.03.1		
		SL 854 C	◆	◆	◆	◆	◆	◆	◆	◆	◆	◆	◆	◆	◆	◆	◆	◆	◆	◆	◆	◆	◆	◆	◆	◆	◆										
SNGN 0904 .. T 	SNGN 090408 T01020	SL 808	◆	◆	◆	◆	◆	◆	◆	◆	◆	◆	◆	◆	◆	◆	◆	◆																	17.10.049.20.1		
SNGN 090404 T - 88Z150 	SNGN 090404 T - 88Z150	SL 808	◆	◆	◆	◆	◆	◆	◆	◆	◆	◆	◆	◆	◆	◆	◆	◆																	17.10.490.20.1		
	SNGN 090404 T01020 - S88Z150	WBN 115																																	12.12.093.20.0		
SNCN 1204 .. T 	SNCN 120404 T00520	SL 500	◆	◆	◆	◆	◆	◆	◆	◆	◆	◆	◆	◆	◆	◆	◆	◆																	36.10.431.03.0		
		SL 808	◆	◆	◆	◆	◆	◆	◆	◆	◆	◆	◆	◆	◆	◆	◆	◆	◆																17.10.431.03.1		
		SL 858 C	◆	◆	◆	◆	◆	◆	◆	◆	◆	◆	◆	◆	◆	◆	◆	◆	◆	◆	◆	◆	◆	◆	◆	◆	◆	◆								21.10.431.03.1	
SNGN 1204 .. T 	SNGN 120408 T01020	SL 500	◆	◆	◆	◆	◆	◆	◆	◆	◆	◆	◆	◆	◆	◆	◆	◆																	36.10.009.20.1		
		SL 808	◆	◆	◆	◆	◆	◆	◆	◆	◆	◆	◆	◆	◆	◆	◆	◆	◆																17.10.009.20.1		
		SL 850 C	◆	◆	◆	◆	◆	◆	◆	◆	◆	◆	◆	◆	◆	◆	◆	◆	◆	◆	◆	◆	◆	◆	◆	◆	◆								15.10.009.20.2		
		SL 854 C	◆	◆	◆	◆	◆	◆	◆	◆	◆	◆	◆	◆	◆	◆	◆	◆	◆	◆	◆	◆	◆	◆	◆	◆	◆	◆	◆							17.10.009.20.9	
		LKM 840	◆	◆	◆	◆	◆	◆	◆	◆	◆	◆	◆	◆	◆	◆	◆	◆	◆	◆	◆	◆	◆	◆	◆	◆	◆	◆						◆		23.10.009.20.2	
	SNGN 120412 T01020	SL 500	◆	◆	◆	◆	◆	◆	◆	◆	◆	◆	◆	◆	◆	◆	◆	◆	◆																36.10.058.20.0		
		SL 808	◆	◆	◆	◆	◆	◆	◆	◆	◆	◆	◆	◆	◆	◆	◆	◆	◆	◆															17.10.058.20.1		
		SL 850 C	◆	◆	◆	◆	◆	◆	◆	◆	◆	◆	◆	◆	◆	◆	◆	◆	◆	◆	◆	◆	◆	◆	◆	◆	◆	◆								15.10.009.20.2	
		SL 854 C	◆	◆	◆	◆	◆	◆	◆	◆	◆	◆	◆	◆	◆	◆	◆	◆	◆	◆	◆	◆	◆	◆	◆	◆	◆	◆	◆							17.10.009.20.9	
		SL 858 C	◆	◆	◆	◆	◆	◆	◆	◆	◆	◆	◆	◆	◆	◆	◆	◆	◆	◆	◆	◆	◆	◆	◆	◆	◆	◆	◆							17.10.058.20.9	
	LKM 840	◆	◆	◆	◆	◆	◆	◆	◆	◆	◆	◆	◆	◆	◆	◆	◆	◆	◆	◆	◆	◆	◆	◆	◆	◆	◆	◆					◆		23.10.058.20.2		
SNCN 1204 ZN T 	SNCN 1204 ZN T00520	SL 500	◆	◆	◆	◆	◆	◆	◆	◆	◆	◆	◆	◆	◆	◆	◆	◆																	36.10.409.03.0		
		SL 808	◆	◆	◆	◆	◆	◆	◆	◆	◆	◆	◆	◆	◆	◆	◆	◆	◆																	17.10.409.03.1	
		SL 854 C	◆	◆	◆	◆	◆	◆	◆	◆	◆	◆	◆	◆	◆	◆	◆	◆	◆	◆	◆	◆	◆	◆	◆	◆	◆	◆								17.10.409.03.9	
		LKM 840	◆	◆	◆	◆	◆	◆	◆	◆	◆	◆	◆	◆	◆	◆	◆	◆	◆	◆	◆	◆	◆	◆	◆	◆	◆	◆	◆					◆		23.10.409.03.2	

ISO application group

- K** ■ Cast iron
- H** ■ Hard materials
- S** ■ HSRA
- P** ■ Steel
- Main application ◆
- Secondary application ◇

Face-milling cutter **PFK75SN**

Rough milling

12.5
▽
6.3
▽



stable / unstable components



$v_c = 600 - 1200$ m/min
 $f_t = 0.14 - 0.30$ mm
 $a_p =$ up to 6 mm

Axial rake angle $\gamma_a = -6^\circ$
Radial rake angle $\gamma_r = -10^\circ$
Connection dimensions as per DIN 8030

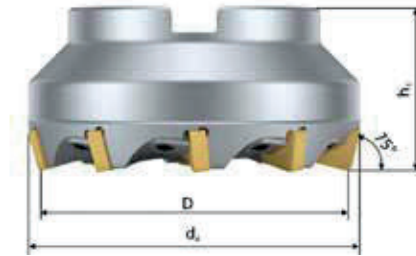

Type	SPK order no.	Dimensions				
		D	Z	d ₄	h ₁	n _{max} (rpm)
PFK-050-05SN1275R-AM	771.00.031.22	50	5	56	40	18000
PFK-063-06SN1275R-AM	771.00.031.32	63	6	69	40	13000
PFK-080-08SN1275R-AM	771.00.031.42	80	8	86	50	10000
PFK-100-10SN1275R-AM	771.00.031.52	100	10	106	50	8000
PFK-125-12SN1275R-AM	771.00.031.62	125	12	131	63	8000
PFK-160-15SN1275R-AM	771.00.031.72	160	15	166	63	6000

For PFK75SN milling cutter with $\varnothing = 50$ mm



For PFK75SN milling cutter with $\varnothing = 63 - 160$ mm

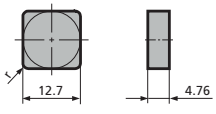
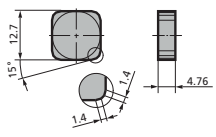

Indexable inserts for **PFK75SN**

INSERT	TYPE	GRADE	K													H	S	P	SPK ORDER NR.												
			GJL			GJS			ADI		SI GJS		GJV																		
			EN-GJL 150	EN-GJL 200	EN-GJL 250	EN-GJL 300	EN-GJL 350	EN-GJS 400-15	EN-GJS 500-7	EN-GJS 600-3	EN-GJS 700-2	EN-GJS 800-2	EN-GJS 800-8	EN-GJS 1000-5	EN-GJS 1200-2	EN-GJS 1400-0	EN-GJS 450-18	EN-GJS 500-14	EN-GJS 600-10	EN-GJV 300	EN-GJV 350	EN-GJV 400	EN-GJV 450	EN-GJV 500	HARD STEEL	CHILLED CAST IRON	DIE CASTING	HSRA	STEEL		
SNGN 1204 .. T 	SNGN 120408 T01020	SL 500	◆	◆	◆	◆	◆										◆	◆													36.10.009.20.0
		SL 808	◆	◆	◆	◆	◆	◆	◆	◆	◆						◆	◆													17.10.009.20.1
		SL 850 C	◆	◆	◆	◆	◆	◆	◆	◆	◆	◆					◆	◆	◆	◆	◆	◆	◆	◆							15.10.009.20.2
		SL 854 C	◆	◆	◆	◆	◆	◆	◆	◆	◆	◆	◆	◆	◆	◆	◆	◆	◆	◆	◆	◆	◆	◆	◆						17.10.009.20.2
		LKM 840	◆	◆	◆	◆	◆	◆	◆	◆	◆	◆	◆				◆	◆										◆		23.10.409.03.2	
		SNGN 120412 T01020	SL 500	◆	◆	◆	◆	◆										◆	◆												36.10.058.20.0
		SL 808	◆	◆	◆	◆	◆	◆	◆	◆	◆	◆					◆	◆	◆	◆	◆	◆	◆								17.10.058.20.1
		SL 850 C	◆	◆	◆	◆	◆	◆	◆	◆	◆	◆					◆	◆	◆	◆	◆	◆	◆	◆							15.10.009.20.2
		SL 854 C	◆	◆	◆	◆	◆	◆	◆	◆	◆	◆	◆	◆	◆	◆	◆	◆	◆	◆	◆	◆	◆	◆	◆						17.10.009.20.9
		LKM 840	◆	◆	◆	◆	◆	◆	◆	◆	◆	◆	◆				◆	◆										◆		23.10.058.20.2	
SNGN 1204 EN T 	SNGN 1204EN T01020	SL 500	◆	◆	◆	◆	◆										◆	◆												36.10.261.20.0	

ISO application group

K ■ Cast iron

H ■ Hard materials

S ■ HSRA

P ■ Steel

Main application ◆

Secondary application ◇

Face-milling cutter **PFK45SN**

Rough milling

12.5
6.3



$v_c = 600 - 1200 \text{ m/min}$
 $f_t = 0.14 - 0.30 \text{ mm}$
 $a_p = \text{up to } 5 \text{ mm}$

Axial rake angle $\gamma_a = -6^\circ$
Radial rake angle $\gamma_r = -12^\circ$
Connection dimensions as per DIN 8030

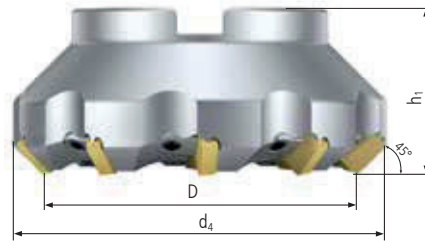
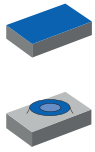

Type	SPK order no.	Dimensions				
		D	Z	d ₄	h ₁	n _{max} (rpm)
PFK-050-05SN1245R-AM	771.00.032.22	50	5	65	40	18000
PFK-063-06SN1245R-AM	771.00.032.32	63	6	78	40	13000
PFK-080-08SN1245R-AM	771.00.032.42	80	8	95	50	10000
PFK-100-10SN1245R-AM	771.00.032.52	100	10	115	50	8000
PFK-125-12SN1245R-AM	771.00.032.62	125	12	140	63	8000
PFK-160-15SN1245R-AM	771.00.032.72	160	15	175	63	6000

For PFK45SN milling cutter with $\varnothing = 50 \text{ mm}$



For PFK45SN milling cutter with $\varnothing = 63 - 160 \text{ mm}$



Indexable inserts for **PFK45SN**

INSERT	TYPE	GRADE	K													H			S	P	SPK ORDER NR.											
			GJL				GJS				ADI		SI GJS		GJV			CHILLED CAST IRON	DIE CASTING	HSRA		STEEL										
			EN-GJL 150	EN-GJL 200	EN-GJL 250	EN-GJL 300	EN-GJL 350	EN-GJS 400-15	EN-GJS 500-7	EN-GJS 600-3	EN-GJS 700-2	EN-GJS 800-2	EN-GJS 800-8	EN-GJS 1000-5	EN-GJS 1200-2	EN-GJS 1400-0	EN-GJS 450-18	EN-GJS 500-14	EN-GJS 600-10	EN-GJV 300	EN-GJV 350	EN-GJV 400	EN-GJV 450	EN-GJV 500	HARD STEEL	CHILLED CAST IRON	DIE CASTING	HSRA	STEEL			
SNCN 1204 ZN T 	SNCN 1204 ZN T00520	SL 500	◆	◆	◆	◆	◆	◆	◆	◆	◆	◆				◇	◇	◇													36.10.409.03.0	
		SL 808	◆	◆	◆	◆	◆	◇	◆	◆	◆	◇				◇	◇	◇													17.10.409.03.1	
		SL 854 C	◆	◆	◆	◆	◆	◆	◆	◆	◆	◆	◆	◆	◆	◆	◆	◆	◆	◆	◆	◆	◆	◆	◆							17.10.409.03.9
		LKM 840	◆	◆	◆	◆	◆	◆	◆	◆	◆	◆	◆				◇	◇	◇										◆			23.10.409.03.2
SNGN 1204 .. T 	SNGN 120412 T01020	SL 500	◆	◆	◆	◆	◆									◇	◇	◇													36.10.058.20.0	
		SL 808	◆	◆	◆	◆	◆	◇	◆	◆	◆	◇				◇	◇	◇														17.10.058.20.1
		SL 850 C	◆	◆	◆	◆	◆	◆	◆	◆	◆	◆					◆	◆	◆													15.10.058.20.2
		SL 854 C	◆	◆	◆	◆	◆	◆	◆	◆	◆	◆	◆	◆	◆	◆	◆	◆	◆	◆	◆	◆	◆	◆	◆							36.10.058.20.9
		LKM 840	◆	◆	◆	◆	◆	◆	◆	◆	◆	◆	◆				◇	◇	◇										◆			23.10.058.20.2
SNGN 1204 AN T 	SNGN 1204 AN T01020	SL 500	◆	◆	◆	◆	◆									◇	◇	◇													36.10.232.20.0	
		SL 808	◆	◆	◆	◆	◆	◇	◆	◆	◆	◇				◇	◇	◇														17.10.232.20.1

ISO application group

K ■ Cast iron	H ■ Hard materials	S ■ HSRA	P ■ Steel	Main application ◆	Secondary application ◇
---	--	---	--	---	---

Face-milling cutter

PFK47HD

Rough milling

12.5
6.3



stable / unstable components

$v_c = 500 - 1200 \text{ m/min}$
 $f_t = 0.12 - 0.30 \text{ mm}$
 $a_p = \text{up to } 5.0 \text{ mm}$

Axial rake angle $\gamma_a = +7^\circ$
 Radial rake angle $\gamma_r = +3^\circ$
 Connection dimensions as per DIN 8030

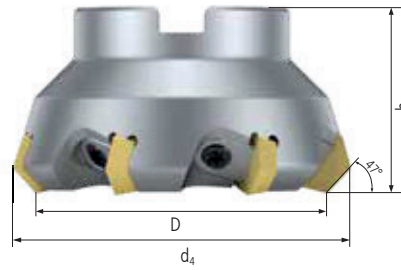

Type	SPK order no.	Dimensions				
		D	Z	d ₄	h ₁	n _{max} (rpm)
PFK-080-07HD1047R-AM	771.00.061.45	80	7	92.5	40	18000
PFK-100-09HD1047R-AM	771.00.061.55	100	9	112.5	40	13000
PFK-125-11HD1047R-AM	771.00.061.65	125	11	137.5	50	10000
PFK-160-14HD1047R-AM	771.00.061.75	160	14	172.5	50	8000

Tightening torque 5 Nm

70.91.55.704.0 70.91.50.357.0

Torx blade ISR

70.91.55.710.0

Cross-handle

70.91.55.706.0

Indexable inserts for **PFK47HD**

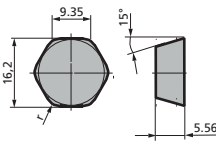
INSERT	TYPE	GRADE	K													H	S	P	SPK ORDER NR.												
			GJL			GJS			ADI			SI GJS			GJV																
			EN-GJL 150	EN-GJL 200	EN-GJL 250	EN-GJL 300	EN-GJL 350	EN-GJS 400-15	EN-GJS 500-7	EN-GJS 600-3	EN-GJS 700-2	EN-GJS 800-2	EN-GJS 800-8	EN-GJS 1000-5	EN-GJS 1200-2	EN-GJS 1400-0	EN-GJS 450-18	EN-GJS 500-14	EN-GJS 600-10	EN-GJV 300	EN-GJV 350	EN-GJV 400	EN-GJV 450	EN-GJV 500	HARD STEEL	CHILLED CAST IRON	DIE CASTING	HRSA	STEEL		
HDGX 10 05 .. T 	HDGX 100512 T01020	SL 808	◆	◆	◆	◆	◆	◆	◆	◆	◆					◆	◆	◆													17.62.014.20.1
	HDGX 100512 T02030	SL 808	◆	◆	◆	◆	◆	◆	◆	◆	◆						◆	◆	◆												17.62.014.52.1

ISO application group

K ■ Cast iron

H ■ Hard materials

S ■ HSRA

P ■ Steel

Main application ◆

Secondary application ◇

Face-milling cutter

PFK47HN

Rough milling

12.5
6.3



stable / unstable components

$v_c = 600 - 1200 \text{ m/min}$
 $f_t = 0.14 - 0.30 \text{ mm}$
 $a_p = \text{up to } 5 \text{ mm}$

Axial rake angle $\gamma_a = -6^\circ$
 Radial rake angle $\gamma_r = -10^\circ$
 Connection dimensions as per DIN 8030

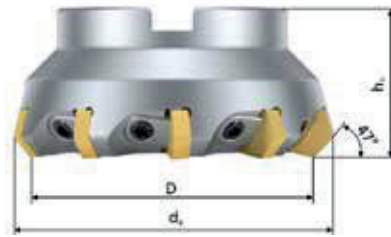
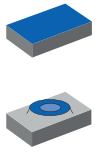

Type	SPK order no.	Dimensions				
		D	Z	d ₄	h ₁	n _{max} (rpm)
PFK-080-08HN1047R-AM	771.00.049.45	80	8	92.5	50	10000
PFK-100-10HN1047R-AM	771.00.049.55	100	10	112.5	50	8000
PFK-125-12HN1047R-AM	771.00.049.65	125	12	137.5	63	6000
PFK-160-16HN1047R-AM	771.00.049.75	160	16	172.5	63	5000

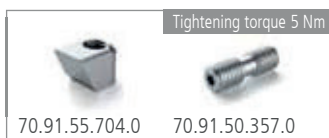

Indexable inserts for **PFK47HN**

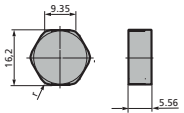
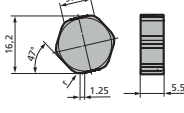
INSERT	TYPE	GRADE	K													H	S	P	SPK ORDER NR.												
			GJL			GJS			ADI			SI GJS			GJV																
			EN-GJL 150	EN-GJL 200	EN-GJL 250	EN-GJL 300	EN-GJL 350	EN-GJS 400-15	EN-GJS 500-7	EN-GJS 600-3	EN-GJS 700-2	EN-GJS 800-2	EN-GJS 800-8	EN-GJS 1000-5	EN-GJS 1200-2	EN-GJS 1400-0	EN-GJS 450-18	EN-GJS 500-14	EN-GJS 600-10	EN-GJV 300	EN-GJV 350	EN-GJV 400	EN-GJV 450	EN-GJV 500	HARD STEEL	CHILLED CAST IRON	DIE CASTING	HSRA	STEEL		
HNGX 1005 .. T 	HNGX 100512 T01020	SL 500	◆	◆	◆	◆											◆	◆													36.60.123.20.0
		SL 808	◆	◆	◆	◆	◇	◆	◆	◆	◇						◆	◆	◆												17.60.123.20.1
	HNGX 100516 T01020	SL 500	◆	◆	◆	◆																									36.60.124.20.0
		SL 808	◆	◆	◆	◆	◇	◆	◆	◆	◇							◆	◆	◆											
HNGX 100516 T - 47Z125 	HNGX 100516 T01020 - 47Z125	SL 500	◆	◆	◆	◆											◆	◆	◆												36.60.120.20.0
	HNGX 100516 T03020 - 47Z125	SL 808	◆	◆	◆	◆	◇	◆	◆	◆	◇						◆	◆	◆												

ISO application group

K ■ Cast iron

H ■ Hard materials

S ■ HSRA

P ■ Steel

Main application ◆

Secondary application ◇

Tangential milling cutter

TFL90WP

Rough milling

12.5
6.3



stable / unstable components

$v_c = 600 - 1200 \text{ m/min}$
 $f_t = 0.12 - 0.30 \text{ mm}$
 $a_p = \text{up to } 4 \text{ mm}$

Axial rake angle $\gamma_a = +4^\circ$
 Radial rake angle γ_r depending on $\phi = -3^\circ$ to -12°
 Connection dimensions as per DIN 8030

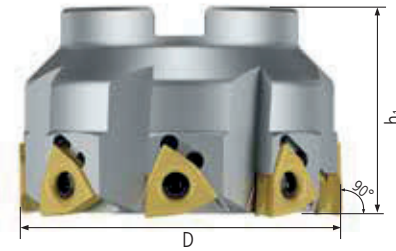
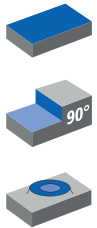

Type	SPK order no.	Dimensions				
		D	Z	d ₄	h ₁	n _{max} (rpm)
TFL-063-06WP0990R-AM	771.00.164.36	63	6	63	40	13000
TFL-080-08WP0990R-AM	771.00.164.46	80	8	80	50	10000
TFL-100-10WP0990R-AM	771.00.164.56	100	10	100	50	8000
TFL-125-12WP0990R-AM	771.00.164.66	125	12	125	63	8000
TFL-160-16WP0990R-AM	771.00.164.76	160	16	160	63	6000

Tightening torque 5 Nm



70.91.50.938.0

Torx blade ISR20



70.91.55.709.0

Cross-handle



70.91.55.706.0

Indexable inserts for **TFL90WP**

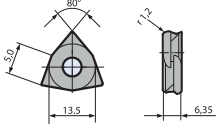
INSERT	TYPE	GRADE	K										H	S	P	SPK ORDER NR.														
			GJL			GJS			ADI	SI GJS		GJV																		
WPHX 0906.. T 	WPHX 090612 T00520	SL 808	EN-GJL 150	EN-GJL 200	EN-GJL 250	EN-GJL 300	EN-GJL 350	EN-GJS 400-15	EN-GJS 500-7	EN-GJS 600-3	EN-GJS 700-2	EN-GJS 800-2	EN-GJS 800-8	EN-GJS 1000-5	EN-GJS 1200-2	EN-GJS 1400-0	EN-GJS 450-18	EN-GJS 500-14	EN-GJS 600-10	EN-GJV 300	EN-GJV 350	EN-GJV 400	EN-GJV 450	EN-GJV 500	HARD STEEL	CHILLED CAST IRON	DIE CASTING	HSRA	STEEL	17.66.035.03.1
			◆	◆	◆	◆	◆	◆	◆	◆	◆	◆	◆	◆	◆	◆	◆	◆	◆	◆	◆	◆	◆	◆	◆	◆	◆	◆	◆	

ISO application group

K ■ Cast iron

H ■ Hard materials

S ■ HSRA

P ■ Steel

Main application ◆

Secondary application ◆

Face-milling cutter

PFL88SP

Rough milling

12.5
6.3



stable / unstable components



$v_c = 600 - 1000 \text{ m/min}$
 $f_t = 0.14 - 0.30 \text{ mm}$
 $a_p = \text{up to } 5 \text{ mm}$

Axial rake angle $\gamma_a = +5^\circ$
 Radial rake angle γ_r depending on $\varnothing = -5^\circ$ to -9°
 Connection dimensions as per DIN 8030

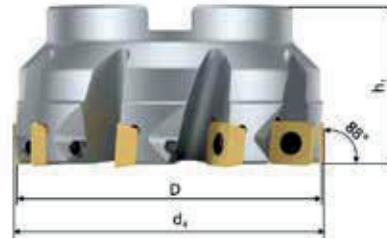
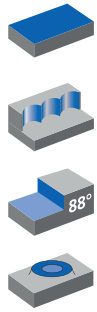

Type	SPK order no.	Dimensions				
		D	Z	d ₄	h ₁	n _{max} (rpm)
PFL-063-05SP1388R-AM	771.00.000.32	63	5	64	40	13000
PFL-080-07SP1388R-AM	771.00.000.42	80	7	81	50	10000
PFL-100-09SP1388R-AM	771.00.000.52	100	9	101	50	8000
PFL-125-11SP1388R-AM	771.00.000.62	125	11	126	63	8000
PFL-160-13SP1388R-AM	771.00.000.72	160	13	161	63	6000
PFL-200-17SP1388R-AM	771.00.000.82	200	17	201	63	4000

Tightening torque 5 Nm



70.91.50.689.0

Torx blade ISR20

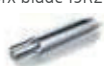

70.91.55.709.0

Cross-handle



70.91.55.706.0

Indexable inserts for **PFL88SP**

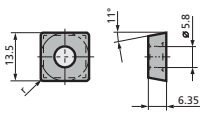
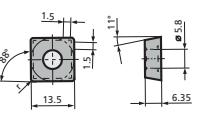
INSERT	TYPE	GRADE	K													H	S	P	SPK ORDER NR.												
			GJL			GJS			ADI			SI GJS			GJV																
			EN-GJL 150	EN-GJL 200	EN-GJL 250	EN-GJL 300	EN-GJL 350	EN-GJS 400-15	EN-GJS 500-7	EN-GJS 600-3	EN-GJS 700-2	EN-GJS 800-2	EN-GJS 800-8	EN-GJS 1000-5	EN-GJS 1200-2	EN-GJS 1400-0	EN-GJS 450-18	EN-GJS 500-14	EN-GJS 600-10	EN-GJV 300	EN-GJV 350	EN-GJV 400	EN-GJV 450	EN-GJV 500	HARD STEEL	CHILLED CAST IRON	DIE CASTING	HSRA	STEEL		
SPHX 1306.. T 	SPHX 130608 T01020	SL 808	◆	◆	◆	◆	◆	◆	◆	◆	◆						◆	◆	◆												17.16.543.20.1
	SPHX 130612 T01020	SL 808	◆	◆	◆	◆	◆	◆	◆	◆	◆							◆	◆	◆											17.16.535.20.1
SPHX 130612 T - 88Z150 	SPHX 130612 T01020 - 88Z150	SL 808	◆	◆	◆	◆	◆	◆	◆	◆	◆							◆	◆	◆											17.16.536.20.1

ISO application group

K ■ Cast iron

H ■ Hard materials

S ■ HSRA

P ■ Steel

Main application ◆

Secondary application ◆

Face-milling cutter **PFL75SP**

Rough milling

12.5
6.3



AWN
stable / unstable components

$v_c = 600 - 1000 \text{ m/min}$
 $f_t = 0.14 - 0.30 \text{ mm}$
 $a_p = \text{up to } 5 \text{ mm}$

Axial rake angle $\gamma_a = +5^\circ$
Radial rake angle γ_r depending on $\varnothing = -5^\circ$ to -9°
Connection dimensions as per DIN 8030

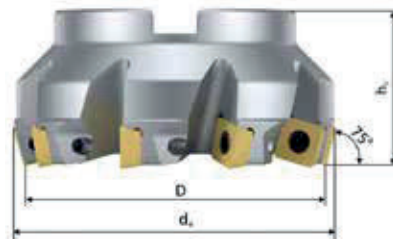
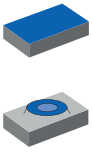

Type	SPK order no.	Dimensions				
		D	Z	d ₄	h ₁	n _{max} (rpm)
PFL-050-04SP1375R-AM	771.00.001.22	50	4	56.5	40	18000
PFL-063-05SP1375R-AM	771.00.001.32	63	5	69.5	40	13000
PFL-080-07SP1375R-AM	771.00.001.42	80	7	86.5	50	10000
PFL-100-09SP1375R-AM	771.00.001.52	100	9	106.5	50	8000
PFL-125-11SP1375R-AM	771.00.001.62	125	11	131.5	63	8000
PFL-160-13SP1375R-AM	771.00.001.72	160	13	166.5	63	6000
PFL-200-17SP1375R-AM	771.00.001.82	200	17	206.5	63	4000

Tightening torque 5 Nm



70.91.50.689.0

Torx blade ISR20



70.91.55.709.0

Cross-handle



70.91.55.706.0

Indexable inserts for **PFL75SP**

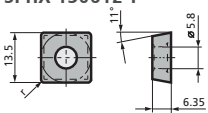
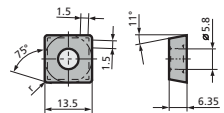
INSERT	TYPE	GRADE	K													H	S	P	SPK ORDER NR.												
			GJL			GJS			ADI		SI GJS		GJV																		
			EN-GJL 150	EN-GJL 200	EN-GJL 250	EN-GJL 300	EN-GJL 350	EN-GJS 400-15	EN-GJS 500-7	EN-GJS 600-3	EN-GJS 700-2	EN-GJS 800-2	EN-GJS 800-8	EN-GJS 1000-5	EN-GJS 1200-2	EN-GJS 1400-0	EN-GJS 450-18	EN-GJS 500-14	EN-GJS 600-10	EN-GJV 300	EN-GJV 350	EN-GJV 400	EN-GJV 450	EN-GJV 500	HARD STEEL	CHILLED CAST IRON	DIE CASTING	HSRA	STEEL		
SPHX 130612 T 	SPHX 130612 T02030	SL 808	◆	◆	◆	◆	◇	◆	◆	◆	◆					◇	◇														17.16.535.52.1
	SPHX 130612 T01020	SL 808	◆	◆	◆	◆	◇	◆	◆	◆	◇						◇	◇	◇												17.16.535.20.1
SPHX 130612 T - 75Z150 	SPHX 130612 T01020 - 75Z150	SL 808	◆	◆	◆	◆	◇	◆	◆	◆	◇						◇	◇	◇											17.16.537.20.1	

ISO application group

K ■ Cast iron

H ■ Hard materials

S ■ HSRA

P ■ Steel

Main application ◆

Secondary application ◇

Face-milling cutter

PFL45SP

Rough milling

12.5
6.3



stable / unstable components

$v_c = 600 - 1000 \text{ m/min}$
 $f_t = 0.14 - 0.30 \text{ mm}$
 $a_p = \text{up to } 5 \text{ mm}$

Axial rake angle $\gamma_a = +5^\circ$
Radial rake angle γ_r depending on $\emptyset = -5^\circ$ to -9°
Connection dimensions as per DIN 8030

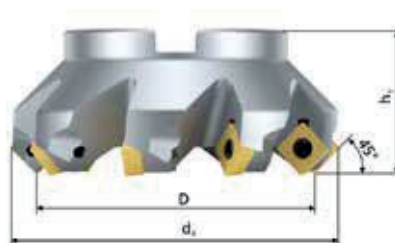
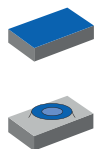

Type	SPK order no.	Dimensions				
		D	Z	d ₄	h ₁	n _{max} (rpm)
PFL-050-05SP1345R-AM	771.00.002.22	50	5	67	40	18000
PFL-063-06SP1345R-AM	771.00.002.32	63	6	80	40	13000
PFL-080-07SP1345R-AM	771.00.002.42	80	7	97	50	10000
PFL-100-09SP1345R-AM	771.00.002.52	100	9	117	50	8000
PFL-125-11SP1345R-AM	771.00.002.62	125	11	142	63	8000
PFL-160-13SP1345R-AM	771.00.002.72	160	13	177	63	6000
PFL-200-17SP1345R-AM	771.00.002.82	200	17	217	63	4000

Tightening torque 5 Nm



70.91.50.689.0

Torx blade ISR20



70.91.55.709.0

Cross-handle



70.91.55.706.0

Indexable inserts for **PFL45SP**

INSERT	TYPE	GRADE	K														H	S	P	SPK ORDER NR.											
			GJL				GJS				ADI		SI GJS		GJV																
			EN-GJL 150	EN-GJL 200	EN-GJL 250	EN-GJL 300	EN-GJL 350	EN-GJS 400-15	EN-GJS 500-7	EN-GJS 600-3	EN-GJS 700-2	EN-GJS 800-2	EN-GJS 800-8	EN-GJS 1000-5	EN-GJS 1200-2	EN-GJS 1400-0	EN-GJS 450-18	EN-GJS 500-14	EN-GJS 600-10	EN-GJV 300	EN-GJV 350	EN-GJV 400	EN-GJV 450	EN-GJV 500	HARD STEEL	CHILLED CAST IRON	DIE CASTING	HSRA	STEEL		
	SPHX 130608 T01020	SL 808	◆	◆	◆	◆	◆	◆	◆	◆	◆	◆					◆	◆													17.16.543.20.1
	SPHX 130612 T01020	SL 808	◆	◆	◆	◆	◆	◆	◆	◆	◆	◆					◆	◆	◆												17.16.533.20.1
	SPHX 130612 T02030	SL 808	◆	◆	◆	◆	◆	◆	◆	◆	◆	◆					◆	◆	◆												17.16.535.52.1

ISO application group

K ■ Cast iron

H ■ Hard materials

S ■ HSRA

P ■ Steel

Main application ◆

Secondary application ◆

Face-milling cutter

PFL43OP

Rough milling

12.5
6.3



AW
stable / unstable components

$v_c = 600 - 1000 \text{ m/min}$
 $f_t = 0.14 - 0.30 \text{ mm}$
 $a_p = \text{up to } 4 \text{ mm}$

Axial rake angle $\gamma_a = +5^\circ$
Radial rake angle γ_r depending on $\phi = -5^\circ$ to -7°
Connection dimensions as per DIN 8030

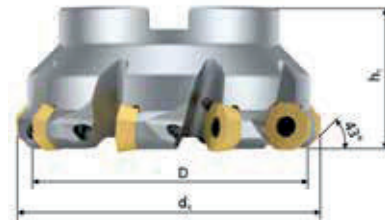

Type	SPK order no.	Dimensions				
		D	Z	d_4	h_1	n_{\max} (rpm)
PFL-050-05OP0643R-AM	771.00.004.24	50	5	61	40	18000
PFL-063-06OP0643R-AM	771.00.004.34	63	6	74	40	13000
PFL-080-07OP0643R-AM	771.00.004.44	80	7	91	50	10000
PFL-100-09OP0643R-AM	771.00.004.54	100	9	111	50	8000
PFL-125-11OP0643R-AM	771.00.004.64	125	11	136	63	8000
PFL-160-13OP0643R-AM	771.00.004.74	160	13	171	63	6000
PFL-200-15OP0643R-AM	771.00.004.84	200	15	211	63	4000

Tightening torque 5 Nm



70.91.50.689.0

Torx blade ISR20



70.91.55.709.0

Cross-handle



70.91.55.706.0

Indexable inserts for **PFL43OP**

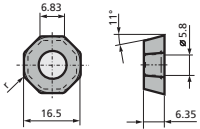
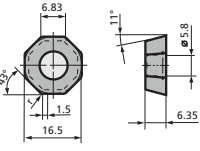
INSERT	TYPE	GRADE	K													H	S	P	SPK ORDER NR.											
			GJL			GJS			ADI	SI GJS			GJV																	
			EN-GJL 150	EN-GJL 200	EN-GJL 250	EN-GJL 300	EN-GJL 350	EN-GJS 400-15	EN-GJS 500-7	EN-GJS 600-3	EN-GJS 700-2	EN-GJS 800-2	EN-GJS 800-8	EN-GJS 1000-5	EN-GJS 1200-2	EN-GJS 1400-0	EN-GJS 450-18	EN-GJS 500-14	EN-GJS 600-10	EN-GJV 300	EN-GJV 350	EN-GJV 400	EN-GJV 450	EN-GJV 500	HARD STEEL	CHILLED CAST IRON	DIE CASTING	HSRA	STEEL	
OPHX 060616 T 	OPHX 060616 T01020	SL 808	◆	◆	◆	◆	◇	◆	◆	◆	◇					◇	◇													17.76.014.201
OPHX 060608 T - 43Z150 	OPHX 060608 T01020 - 43Z150	SL 808	◆	◆	◆	◆	◇	◆	◆	◆	◇					◇	◇	◇												17.76.015.20.1

ISO application group

K	■ Cast iron	H	■ Hard materials	S	■ HSRA	P	■ Steel	Main application ◆	Secondary application ◇
----------	---	----------	--	----------	--	----------	--	--------------------	-------------------------

Face-milling cutter **PFL43OE**

Rough milling

12.5
6.3



$v_c = 600 - 1000 \text{ m/min}$
 $f_t = 0.14 - 0.30 \text{ mm}$
 $a_p = \text{up to } 4 \text{ mm}$

Axial rake angle $\gamma_a = +14^\circ$
Radial rake angle $\gamma_r = +2^\circ$
Connection dimensions as per DIN 8030

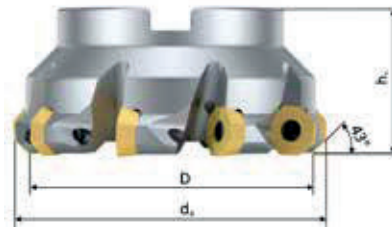

Type	SPK order no.	Dimensions				
		D	Z	d ₄	h ₁	n _{max} (rpm)
PFL-050-04OE0643R-AM	771.00.005.24	50	4	60.5	40	18000
PFL-063-05OE0643R-AM	771.00.005.34	63	5	73.5	40	13000
PFL-080-06OE0643R-AM	771.00.005.44	80	6	90.5	50	10000
PFL-100-07OE0643R-AM	771.00.005.54	100	7	110.5	50	8000
PFL-125-09OE0643R-AM	771.00.005.64	125	9	135.5	63	8000
PFL-160-11OE0643R-AM	771.00.005.74	160	11	170.5	63	6000
PFL-200-13OE0643R-AM	771.00.005.84	200	13	210.5	63	4000

Tightening torque 5 Nm



70.91.50.689.0

Torx blade ISR20



70.91.55.709.0

Cross-handle



70.91.55.706.0

Indexable inserts for **PFL43**OE

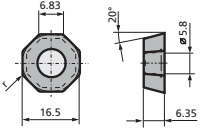
INSERT	TYPE	GRADE	K											H	S	P	SPK ORDER NR.															
			GJL			GJS			ADI		SI GJS		GJV																			
	OEHX060616 T01020	SL 808	EN-GIL 150	EN-GIL 200	EN-GIL 250	EN-GIL 300	EN-GIL 350	EN-GJS 400-15	EN-GJS 500-7	EN-GJS 600-3	EN-GJS 700-2	EN-GJS 800-2	EN-GJS 800-8	EN-GJS 1000-5	EN-GJS 1200-2	EN-GJS 1400-0	EN-GJS 450-18	EN-GJS 500-14	EN-GJS 600-10	EN-GJV 300	EN-GJV 350	EN-GJV 400	EN-GJV 450	EN-GJV 500	HARD STEEL	CHILLED CAST IRON	DIE CASTING	HRSA	STEEL	17.76.016.20.1		
			◆	◆	◆	◆	◆	◆	◆	◆	◆	◆	◆				◆	◆	◆													

ISO application group

K ■ Cast iron	H ■ Hard materials	S ■ HSRA	P ■ Steel	Main application ◆	Secondary application ◆
---	--	---	---	---	---

Face-milling cutter

PFL43ON

Rough milling

12.5
6.3



stable / unstable components



$v_c = 600 - 1000 \text{ m/min}$
 $f_t = 0.14 - 0.30 \text{ mm}$
 $a_p = \text{up to } 4 \text{ mm}$

Axial rake angle $\gamma_a = -6^\circ$
 Radial rake angle $\gamma_r = -6^\circ$
 Connection dimensions as per DIN 8030

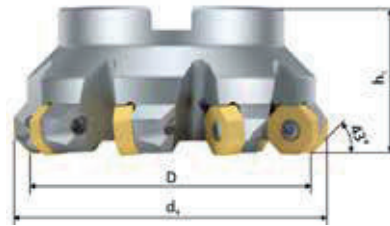

Type	SPK order no.	Dimensions				
		D	Z	d ₄	h ₁	n _{max} (rpm)
PFL-063-06ON0643R-AM	771.00.039.34	63	6	74	40	13000
PFL-080-07ON0643R-AM	771.00.039.44	80	7	91	50	10000
PFL-100-09ON0643R-AM	771.00.039.54	100	9	111	50	8000
PFL-125-10ON0643R-AM	771.00.039.64	125	10	136	63	8000
PFL-160-12ON0643R-AM	771.00.039.74	160	12	171	63	6000

Tightening torque 5 Nm



70.91.50.689.0

Torx blade ISR20



70.91.55.709.0

Cross-handle



70.91.55.706.0

Indexable inserts for **PFL43ON**

INSERT	TYPE	GRADE	K														H	S	P	SPK ORDER NR.											
			GJL			GJS			ADI			SI GJS			GJV																
			EN-GIL 150	EN-GIL 200	EN-GIL 250	EN-GIL 300	EN-GIL 350	EN-GIS 400-15	EN-GIS 500-7	EN-GIS 600-3	EN-GIS 700-2	EN-GIS 800-2	EN-GIS 800-8	EN-GIS 1000-5	EN-GIS 1200-2	EN-GIS 1400-0	EN-GIS 450-18	EN-GIS 500-14	EN-GIS 600-10	EN-GIV 300	EN-GIV 350	EN-GIV 400	EN-GIV 450	EN-GIV 500	HARD STEEL	CHILLED CAST IRON	DIE CASTING	HSRA	STEEL		
	ONHX 060608 T01020	SL 808	◆	◆	◆	◆	◆	◆	◆	◆	◆	◆					◆	◆	◆												17.76.019.20.1
	ONHX 060612 T01020	SL 808	◆	◆	◆	◆	◆	◆	◆	◆	◆	◆					◆	◆	◆												17.76.020.20.1
	ONHX 060616 T01020	SL 808	◆	◆	◆	◆	◆	◆	◆	◆	◆	◆					◆	◆	◆												17.76.017.20.1

ISO application group

K ■ Cast iron

H ■ Hard materials

S ■ HSRA

P ■ Steel

Main application ◆

Secondary application ◆

High-feed / drill / circular milling cutter

BFL75SP

Rough milling

12.5
6.3



stable / unstable components



$v_c = 600 - 1400 \text{ m/min}$
 $f_t = 0.14 - 0.30 \text{ mm}$
 $a_p = \text{up to } 2 \text{ mm}$

Axial rake angle $\gamma_a = +5^\circ$
 Radial rake angle $\gamma_r = 0^\circ$
 Connection dimensions as per DIN 8030

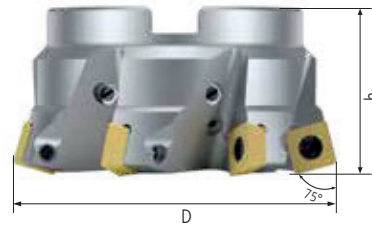
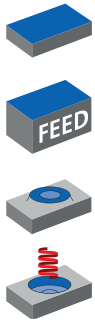

Type	SPK order no.	Dimensions				
		D	Z	d ₄	h ₁	n _{max} (rpm)
BFL-063-05SP1375R-AMCL	775.00.000.32	63	5	-	40	13000
BFL-080-06SP1375R-AMCL	775.00.000.42	80	6	-	50	10000
BFL-100-07SP1375R-AMCL	775.00.000.52	100	7	-	50	6000

Tightening torque 5 Nm



70.91.50.689.0

Torx blade ISR20



70.91.55.709.0

Cross-handle



70.91.55.706.0

Indexable inserts for **BFL75SP**

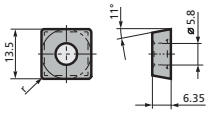
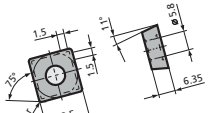
INSERT	TYPE	GRADE	K													H	S	P	SPK ORDER NR.												
			GJL			GJS			ADI		SI GJS		GJV																		
			EN-GJL 150	EN-GJL 200	EN-GJL 250	EN-GJL 300	EN-GJL 350	EN-GJS 400-15	EN-GJS 500-7	EN-GJS 600-3	EN-GJS 700-2	EN-GJS 800-2	EN-GJS 800-8	EN-GJS 1000-5	EN-GJS 1200-2	EN-GJS 1400-0	EN-GJS 450-18	EN-GJS 500-14	EN-GJS 600-10	EN-GJV 300	EN-GJV 350	EN-GJV 400	EN-GJV 450	EN-GJV 500	HARD STEEL	CHILLED CAST IRON	DIE CASTING	HSRA	STEEL		
SPHX 130612 T 	SPHX 130612 T01020	SL 808	◆	◆	◆	◆	◆	◆	◆	◆	◆	◆					◆	◆	◆												17.16.535.20.1
	SPHX 130612 T02030	SL 808	◆	◆	◆	◆	◆	◆	◆	◆	◆	◆					◆	◆	◆												17.16.535.52.1
SPHX 130612 T - 75Z150 	SPHX 130612 T01020 - 75Z150	SL 808	◆	◆	◆	◆	◆	◆	◆	◆	◆	◆					◆	◆	◆												17.16.537.20.1

ISO application group

K ■ Cast iron

H ■ Hard materials

S ■ HSRA

P ■ Steel

Main application ◆

Secondary application ◆

Face-milling cutter **PMK88SN**

Finish milling

6.3 / 3.2 / 0.8



stable / unstable components



$v_c = 700 - 1000$ m/min
 $f_t = 0.16 - 0.30$ mm
 $a_p = 0.5 - 1.0$ mm

Axial rake angle $\gamma_a = -6^\circ$
Radial rake angle γ_r , depending on $\emptyset = -6^\circ$ to -9°
Connection dimensions as per DIN 8030

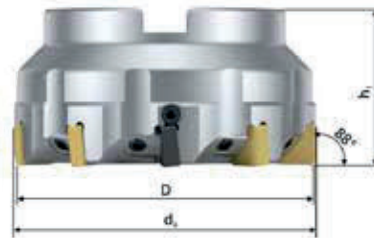

Type	SPK order no.	Dimensions					
		D	Z	d ₄	h ₁	n _{max} (rpm)	Weight (kg)
PMK-063-06SN1288R-AM	771.00.033.32	63	6 (5+1)	64	40	13000	0.60
PMK-080-08SN1288R-AM	771.00.033.42	80	8 (7+1)	81	50	10000	1.30
PMK-100-10SN1288R-AM	771.00.033.52	100	10 (9+1)	101	50	8000	1.90
PMK-125-12SN1288R-AM	771.00.033.62	125	12 (10+2)	126	63	6000	3.50
PMK-160-14SN1288R-AM	771.00.033.72	160	14 (12+2)	161	63	6000	4.60
PMK-200-16SN1288R-AM	771.00.033.82	200	16 (14+2)	201	63	4000	7.00
PMK-250-21SN1288R-AM	771.00.033.92	250	21 (18+3)	251	63	3000	13.00

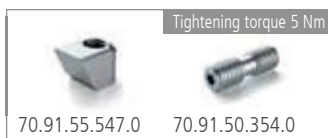

Indexable inserts for **PMK88SN**

INSERT	TYPE	GRADE	K														H	S	P	SPK ORDER NR.																			
			GJL			GJS				ADI			SI GJS		GJV			HARD STEEL	CHILLED CAST IRON		DIE CASTING	HSRA	STEEL																
			EN-GJL 150	EN-GJL 200	EN-GJL 250	EN-GJL 300	EN-GJL 350	EN-GJS 400-15	EN-GJS 500-7	EN-GJS 600-3	EN-GJS 700-2	EN-GJS 800-2	EN-GJS 800-8	EN-GJS 1000-5	EN-GJS 1200-2	EN-GJS 1400-0	EN-GJS 450-18							EN-GJS 500-14	EN-GJS 600-10	EN-GJV 300	EN-GJV 350	EN-GJV 400	EN-GJV 450	EN-GJV 500									
	SNCN 1204 ZN T00520	SL 500	♦	♦	♦	♦	♦	♦	♦	♦	♦	♦	♦	♦	♦	♦	♦	♦	♦	♦																			36.10.409.03.0
		SL 808	♦	♦	♦	♦	♦	♦	♦	♦	♦					♦	♦	♦																					17.10.409.03.1
		SL 854 C	♦	♦	♦	♦	♦	♦	♦	♦	♦	♦	♦	♦	♦	♦	♦	♦	♦	♦	♦	♦	♦	♦	♦	♦	♦	♦	♦	♦	♦	♦	♦	♦	♦	♦	♦		17.10.409.03.9
		LKM 840	♦	♦	♦	♦	♦	♦	♦	♦	♦	♦																									♦		23.10.409.03.2
	SNGN 120408 T01020	SL 500	♦	♦	♦	♦	♦																															36.10.009.20.0	
		SL 808	♦	♦	♦	♦	♦	♦	♦	♦	♦																												17.10.009.20.1
		LKM 840	♦	♦	♦	♦	♦	♦	♦	♦	♦																										♦		23.10.009.20.2
	SNGN 120412 T01020	SL 500	♦	♦	♦	♦																																	36.10.058.20.0
		SL 808	♦	♦	♦	♦	♦	♦	♦	♦	♦																												17.10.058.20.1
		SL 850 C	♦	♦	♦	♦	♦	♦	♦	♦	♦																												15.10.058.20.2
		SL 854 C	♦	♦	♦	♦	♦	♦	♦	♦	♦	♦	♦	♦	♦	♦	♦	♦	♦	♦	♦	♦	♦	♦	♦	♦	♦	♦	♦	♦	♦	♦	♦	♦	♦	♦	♦		17.10.058.20.9
		SL 858 C	♦	♦	♦	♦	♦	♦	♦	♦	♦	♦	♦	♦	♦	♦	♦	♦	♦	♦	♦	♦	♦	♦	♦	♦	♦	♦	♦	♦	♦	♦	♦	♦	♦	♦	♦	♦	
LKM 840	♦	♦	♦	♦	♦	♦	♦	♦	♦																											♦		23.10.058.20.2	
	SNGN 1204 ZN T01020 - 88Z240	SC 60	♦	♦	♦	♦	♦	♦	♦	♦																												♦	46.10.048.20.6
		SL 500	♦	♦	♦	♦																																	36.10.493.20.0
		SL 808	♦	♦	♦	♦	♦	♦	♦	♦	♦																												
	SNGN 1204 ZN T01020 - S 88Z240	WBN 115	♦	♦	♦	♦	♦	♦	♦	♦	♦	♦	♦																										12.12.089.20.0
	SNGN 120408 T01020 - 88Z240	SC 60	♦	♦	♦	♦	♦	♦	♦	♦																											♦	46.10.049.20.6	
		SL 500	♦	♦	♦	♦																																	36.10.503.20.0
		SL 808	♦	♦	♦	♦	♦	♦	♦	♦	♦																												17.10.503.20.1
		SL 854 C	♦	♦	♦	♦	♦	♦	♦	♦	♦	♦	♦	♦	♦	♦	♦	♦	♦	♦	♦	♦	♦	♦	♦	♦	♦	♦	♦	♦	♦	♦	♦	♦	♦	♦	♦		17.10.503.20.9
	SNGN 1204 ZN T01015 - S 88Z300	WBN 101	♦	♦	♦	♦	♦	♦	♦	♦	♦	♦																										20.12.085.37.1	
		WBN 115	♦	♦	♦	♦	♦	♦	♦	♦	♦	♦	♦																									♦	12.12.085.37.0

ISO application group

K ■ Cast iron

H ■ Hard materials

S ■ HSRA

P ■ Steel

Main application ♦

Secondary application ◇

Face-milling cutter **PMKS88SN**

Finish milling

6.3
3.2
0.8



stable / unstable components

$v_c = 700 - 1000 \text{ m/min}$
 $f_t = 0.16 - 0.20 \text{ mm}$
 $a_p = 0.5 - 1.0 \text{ mm}$

Axial rake angle $\gamma_a = -6^\circ$
Radial rake angle γ_r , depending on $\theta = -6^\circ$ to -9°
Connection dimensions as per DIN 8030

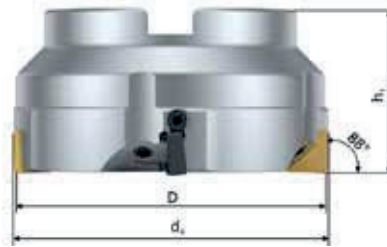
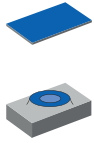

Type	SPK order no.	Dimensions					
		D	Z	d ₁	h ₁	n _{max} (rpm)	Weight (kg)
PMK S 063-04SN1288R-AM	778.00.000.32	63	4 (3+1)	64	40	13000	0.60
PMK S 080-05SN1288R-AM	778.00.000.42	80	5 (4+1)	81	50	10000	1.30
PMK S 100-05SN1288R-AM	778.00.000.52	100	5 (4+1)	101	50	8000	1.90
PMK S 125-06SN1288R-AM	778.00.000.62	125	6 (5+1)	126	63	8000	3.50
PMK S 160-08SN1288R-AM	778.00.000.72	160	8 (7+1)	161	63	6000	4.60

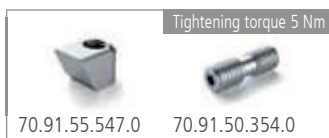

Indexable inserts for **PMKS88SN**

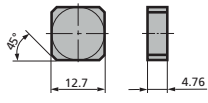
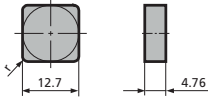
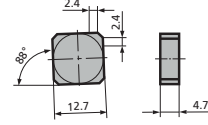
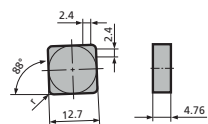
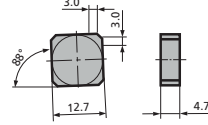
INSERT	TYPE	GRADE	K														H	S	P	SPK ORDER NR.											
			GJL				GJS				ADI		SI GJS		GJV		HARD STEEL	CHILLED CAST IRON	DIE CASTING		HRSA	STEEL									
			EN-GJL 150	EN-GJL 200	EN-GJL 250	EN-GJL 300	EN-GJL 350	EN-GJS 400-15	EN-GJS 500-7	EN-GJS 600-3	EN-GJS 700-2	EN-GJS 800-2	EN-GJS 800-8	EN-GJS 1000-5	EN-GJS 1200-2	EN-GJS 1400-0	EN-GJS 450-18	EN-GJS 500-14	EN-GJS 600-10	EN-GJV 300	EN-GJV 350	EN-GJV 400	EN-GJV 450	EN-GJV 500							
SNCN 1204 ZN T 	SNCN 1204 ZN T00520	SL 500	◆	◆	◆	◆	◆	◆	◆	◆	◆						◇	◇													36.10.409.03.0
		SL 808	◆	◆	◆	◆	◆	◆	◆	◆	◆	◆						◇	◇												17.10.409.03.1
		SL 854 C	◆	◆	◆	◆	◆	◆	◆	◆	◆	◆	◆	◆	◆	◆	◆	◆	◇	◇	◆	◆	◆	◆	◆	◆					17.10.409.03.9
		LKM 840	◆	◆	◆	◆	◆	◆	◆	◆	◆	◆	◆	◆	◆	◆	◆	◆	◇	◇								◆			23.10.409.03.2
SNGN 1204 .. T 	SNGN 120408 T01020	SL 500	◆	◆	◆	◆	◆										◇	◇												36.10.009.20.0	
		SL 808	◆	◆	◆	◆	◆	◆	◆	◆	◆	◆						◇	◇												17.10.009.20.1
		LKM 840	◆	◆	◆	◆	◆	◆	◆	◆	◆	◆	◆	◆	◆	◆	◆	◇	◇								◆			23.10.009.20.2	
	SNGN 120412 T01020	SL 500	◆	◆	◆	◆	◆											◇	◇												36.10.058.20.0
		SL 808	◆	◆	◆	◆	◆	◆	◆	◆	◆	◆						◇	◇												17.10.058.20.1
		SL 850 C	◆	◆	◆	◆	◆	◆	◆	◆	◆	◆	◆	◆	◆	◆	◆	◇	◇												
		SL 854 C	◆	◆	◆	◆	◆	◆	◆	◆	◆	◆	◆	◆	◆	◆	◆	◆	◇	◇	◆	◆	◆	◆	◆	◆					17.10.058.20.9
		SL 858 C	◆	◆	◆	◆	◆	◆	◆	◆	◆	◆	◆	◆	◆	◆	◆	◆	◇	◇	◆	◆	◆	◆	◆	◆					21.10.058.20.1
LKM 840	◆	◆	◆	◆	◆	◆	◆	◆	◆	◆	◆	◆	◆	◆	◆	◆	◇	◇								◆			23.10.058.20.2		
SNGN 1204 ZN T - . 88Z240 	SNGN 1204 ZN T01020 - 88Z240	SC 60	◆	◆	◆	◆	◆	◆	◆	◆	◆						◇	◇												◆	46.10.048.20.6
		SL 500	◆	◆	◆	◆	◆											◇	◇												36.10.493.20.0
		SL 808	◆	◆	◆	◆	◆	◆	◆	◆	◆	◆	◆	◆	◆	◆	◆	◇	◇												17.10.493.20.1
	SNGN 1204 ZN T01020 - S 88Z240	WBN 115	◆	◆	◆	◆	◆	◆	◆	◆	◆	◆	◆	◆	◆	◆	◆	◇	◇												12.12.089.20.0
SNGN 120408 T - 88Z240 	SNGN 120408 T01020 - 88Z240	SC 60	◆	◆	◆	◆	◆	◆	◆	◆	◆						◇	◇												◆	46.10.049.20.6
		SL 500	◆	◆	◆	◆	◆											◇	◇												36.10.503.20.0
		SL 808	◆	◆	◆	◆	◆	◆	◆	◆	◆	◆	◆	◆	◆	◆	◆	◇	◇												17.10.503.20.1
		SL 854 C	◆	◆	◆	◆	◆	◆	◆	◆	◆	◆	◆	◆	◆	◆	◆	◆	◇	◇	◆	◆	◆	◆	◆	◆					17.10.503.20.9
SNGN 1204 ZN T - S 88Z300 	SNGN 1204 ZN T01015 - S 88Z300	WBN 101	◆	◆	◆	◆	◆	◆	◆	◆	◆	◆	◆	◆	◆	◆	◇	◇													20.12.085.37.1
		WBN 115	◆	◆	◆	◆	◆	◆	◆	◆	◆	◆	◆	◆	◆	◆	◆	◇	◇									◆			12.12.085.37.0

ISO application group

K ■ Cast iron	H ■ Hard materials	S ■ HSRA	P ■ Steel	Main application ◆	Secondary application ◇
---	--	---	--	---	---

Face-milling cutter **PDK88SN**

Finish milling

3.2
▽
0.8
▽



$v_c = 700 - 1000 \text{ m/min}$
 $f_t = 0.16 - 0.20 \text{ mm}$
 $a_p = 0.5 - 1.0 \text{ mm}$

Axial rake angle $\gamma_a = -6^\circ$
Radial rake angle γ_r depending on $\phi = -6^\circ$ to -9°
Connection dimensions as per DIN 8030

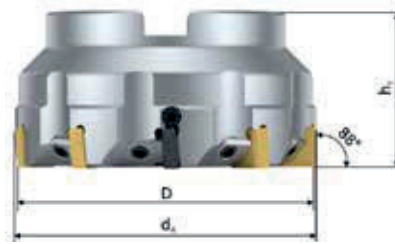
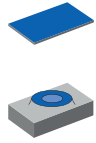

Type	SPK order no.	Dimensions					Weight (kg)
		D	Z	C ₄	h ₁	n _{max} (rpm)	
PDK-063-06SN1288R-AM	778.00.004.22	63	6 (5+1)	64	40	13000	0.60
PDK-080-08SN1288R-AM	778.00.003.42	80	8 (7+1)	81	50	10000	1.30
PDK-100-10SN1288R-AM	778.00.003.92	100	10 (9+1)	101	50	8000	1.90
PDK-125-12SN1288R-AM	778.00.003.72	125	12 (10+2)	126	63	8000	3.50
PDK-160-14SN1288R-AM	778.00.004.32	160	14 (12+2)	161	63	6000	4.60
PDK-200-16SN1288R-AM	778.00.004.02	200	16 (14+2)	201	63	4000	7.00
PDK-250-18SN1288R-AM	778.00.003.12	250	18 (15+3)	251	63	3000	13.30

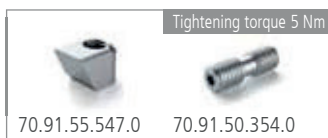

Indexable inserts for **PDK88SN**

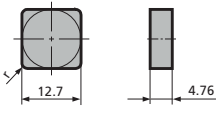
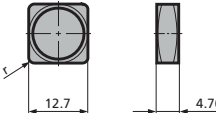
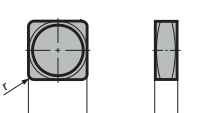
INSERT	TYPE	GRADE	K													H	S	P	SPK ORDER NR.											
			GJL			GJS			ADI		SI GJS		GJV			HARD STEEL	CHILLED CAST IRON	DIE CASTING		HSRA	STEEL									
			EN-GJL 150	EN-GJL 200	EN-GJL 250	EN-GJL 300	EN-GJL 350	EN-GJS 400-15	EN-GJS 500-7	EN-GJS 600-3	EN-GJS 700-2	EN-GJS 800-2	EN-GJS 800-8	EN-GJS 1000-5	EN-GJS 1200-2				EN-GJS 1400-0			EN-GJS 450-18	EN-GJS 500-14	EN-GJS 600-10	EN-GJV 300	EN-GJV 350	EN-GJV 400	EN-GJV 450	EN-GJV 500	
SNGN 1204 T 	SNGN 120412 T01020	SL 500	◆	◆	◆	◆	◆										◆	◆												36.10.058.20.0
		SL 808	◆	◆	◆	◆	◆	◆	◆	◆	◆	◆					◆	◆	◆											17.10.058.20.1
		LKM 840	◆	◆	◆	◆	◆	◆	◆	◆	◆	◆					◆	◆	◆									◆		23.10.058.20.2
	SNGN 120412 T	SC 30	◆	◆	◆	◆	◆	◆	◆	◆	◆	◆					◆	◆	◆									◆		46.10.001.40.2
SNGX 1204 .. T124 	SNGX 120412 T124	SC 30	◆	◆	◆	◆	◆	◆	◆	◆	◆	◆					◆	◆	◆									◆	46.10.016.99.2	
SNHX 1204 .. T125 	SNHX 120412 T125	SH 2	◆	◆	◆	◆	◆																						36.10.266.99.7	
	SNHX 120412 T125-S	WBN 101	◆	◆	◆	◆	◆	◆	◆	◆	◆	◆					◆	◆	◆									◆	20.18.801.99.1	
		WBN 115	◆	◆	◆	◆	◆	◆	◆	◆	◆	◆					◆	◆	◆									◆	12.18.801.99.0	

ISO application group

K ■ Cast iron

H ■ Hard materials

S ■ HSRA

P ■ Steel

Main application ◆

Secondary application ◆

Face-milling cutter **PEK88SN**

Finish milling

6.3 / 3.2 / 0.8



stable / unstable components



$v_c = 700 - 1000 \text{ m/min}$
 $f_t = 0.12 - 0.20 \text{ mm}$
 $a_p = 0.5 - 1.0 \text{ mm}$

Axial rake angle $\gamma_a = -6^\circ$
Radial rake angle γ_r depending on $\phi = -6^\circ$ to -10°
Connection dimensions as per DIN 8030

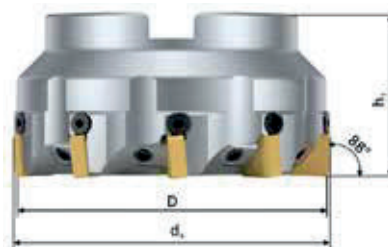
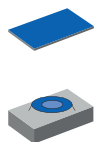

Type	SPK order no.	Dimensions					
		D	Z	d ₁	h ₁	n _{max} (rpm)	Weight (kg)
PEK-050-05SN1288R-AM	771.00.036.22	50	5	51	40	18000	0.30
PEK-063-06SN1288R-AM	771.00.036.32	63	6	64	40	13000	0.60
PEK-080-08SN1288R-AM	771.00.036.42	80	8	81	50	10000	1.20
PEK-100-10SN1288R-AM	771.00.036.52	100	10	101	50	8000	1.80
PEK-125-12SN1288R-AM	771.00.036.62	125	12	126	63	6000	3.40
PEK-160-15SN1288R-AM	771.00.036.72	160	15	161	63	6000	4.50
PEK-200-20SN1288R-AM	771.00.036.82	200	20	201	63	4000	6.90
PEK-250-24SN1288R-AM	771.00.036.92	250	24	251	63	3000	13.00

For PEK SN milling cutter with $\phi = 50 \text{ mm}$



For PEK SN milling cutter with $\phi = 63 - 250 \text{ mm}$



Adjusting manual on page 87

Indexable inserts for **PEK88SN**

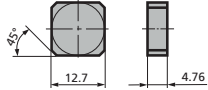
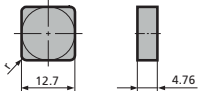
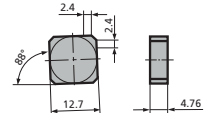
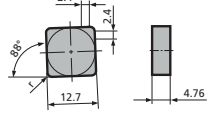
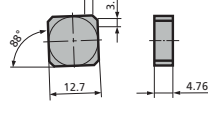
INSERT	TYPE	GRADE	K													H	S	P	SPK ORDER NR.											
			GJL			GJS			ADI		SI GJS		GJV			CHILLED CAST IRON	DIE CASTING	HRSA		STEEL										
			EN-GJL 150	EN-GJL 200	EN-GJL 250	EN-GJL 300	EN-GJL 350	EN-GJS 400-15	EN-GJS 500-7	EN-GJS 600-3	EN-GJS 700-2	EN-GJS 800-2	EN-GJS 800-8	EN-GJS 1000-5	EN-GJS 1200-2	EN-GJS 1400-0	EN-GJS 450-18	EN-GJS 500-14	EN-GJS 600-10	EN-GJV 300	EN-GJV 350	EN-GJV 400	EN-GJV 450	EN-GJV 500	HARD STEEL					
SNCN 1204 ZN T 	SNCN 1204 ZN T00520	SL 500	◆	◆	◆	◆	◆	◆	◆	◆	◆	◆					◇	◇												36.10.409.03.0
		SL 808	◆	◆	◆	◆	◆	◇	◆	◆	◆	◆					◇	◇												17.10.409.03.1
		SL 854 C	◆	◆	◆	◆	◆	◆	◆	◆	◆	◆	◆	◆	◆	◆	◆	◆	◆	◆	◆	◆	◆	◆	◆					17.10.409.03.9
		LKM 840	◆	◆	◆	◆	◆	◆	◆	◆	◆	◆	◆					◇	◇									◆		23.10.409.03.2
SNGN 1204 .. T 	SNGN 120408 T01020	SL 500	◆	◆	◆	◆	◆										◇	◇											36.10.009.20.0	
		SL 808	◆	◆	◆	◆	◆	◇	◆	◆	◆	◆					◇	◇												17.10.009.20.1
		LKM 840	◆	◆	◆	◆	◆	◆	◆	◆	◆	◆					◇	◇										◆		23.10.009.20.2
	SNGN 120412 T01020	SL 500	◆	◆	◆	◆	◆											◇	◇											36.10.058.20.0
		SL 808	◆	◆	◆	◆	◆	◇	◆	◆	◆	◆					◇	◇												17.10.058.20.1
		SL 854 C	◆	◆	◆	◆	◆	◆	◆	◆	◆	◆	◆	◆	◆	◆	◆	◆	◆	◆	◆	◆	◆	◆	◆					17.10.058.20.9
		SL 858 C	◆	◆	◆	◆	◆	◆	◆	◆	◆	◆	◆	◆	◆	◆	◆	◆	◆	◆	◆	◆	◆	◆	◆					21.10.058.20.1
	LKM 840	◆	◆	◆	◆	◆	◆	◆	◆	◆	◆	◆					◇	◇									◆		23.10.058.20.2	
SNGN 1204 ZN T - . 88Z240 	SNGN 1204 ZN T01020 - 88Z240	SC 60	◆	◆	◆	◆	◆	◆	◆	◆	◆						◇	◇											◆	46.10.048.20.6
		SL 500	◆	◆	◆	◆	◆											◇	◇											36.10.493.20.0
		SL 808	◆	◆	◆	◆	◆	◇	◆	◆	◆	◆					◇	◇												17.10.493.20.1
	SNGN 1204 ZN T01020 - S 88Z240	WBN 115	◆	◆	◆	◆	◆	◇	◆	◆	◆	◆					◇	◇												12.12.089.20.0
SNGN 120408 T - 88Z240 	SNGN 120408 T01020 - 88Z240	SC 60	◆	◆	◆	◆	◆	◆	◆	◆	◆						◇	◇											◆	46.10.049.20.6
		SL 500	◆	◆	◆	◆	◆											◇	◇											36.10.503.20.0
		SL 808	◆	◆	◆	◆	◆	◇	◆	◆	◆	◆					◇	◇												17.10.503.20.1
		SL 854 C	◆	◆	◆	◆	◆	◆	◆	◆	◆	◆	◆	◆	◆	◆	◆	◆	◆	◆	◆	◆	◆	◆	◆					17.10.503.20.9
SNGN 1204 ZN T - S 88Z300 	SNGN 1204 ZN T01015 - S 88Z300	WBN 101	◆	◆	◆	◆	◆	◇	◆	◆	◆						◇	◇											20.12.085.37.1	
		WBN 115	◆	◆	◆	◆	◆	◆	◇	◆	◆	◆					◇	◇										◆		12.12.085.37.0

ISO application group

K ■ Cast iron	H ■ Hard materials	S ■ HSRA	P ■ Steel	Main application ◆	Secondary application ◇
---	--	---	--	---	---

Face-milling cutter **PMC43OP**

Finish milling

3.2
1.6



$v_c = 700 - 1000 \text{ m/min}$
 $f_t = 0.12 - 0.20 \text{ mm}$
 $a_p = 0.2 - 1.5 \text{ mm}$

Axial rake angle $\gamma_a = +4^\circ$
Radial rake angle γ_r depending on $\theta = 0^\circ$
Connection dimensions as per DIN 8030

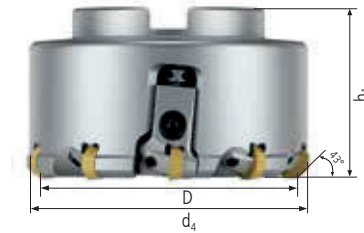
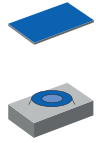

Type	SPK order no.	Dimensions					
		D	Z	d ₁	h ₁	n _{max} (rpm)	Weight (kg)
Standard pitch							
PMC-100-100P0543R-AM	771.20.421.54	100	10 (9+1)	108.5	63	8000	2.80
PMC-125-120P0543R-AM	771.20.421.64	125	12 (10+2)	133.5	63	8000	4.20
PMC-160-140P0543R-AM	771.20.421.74	160	14 (12+2)	168.5	63	6000	6.50
PMC-200-200P0543R-AM	771.20.421.84	200	20 (18+2)	208.5	63	4000	9.50
PMC-250-240P0543R-AM	771.20.421.94	250	24 (21+3)	258.5	63	3000	14.80
Wide pitch							
PMC-160-100P0543R-AM	771.20.121.74	160	10 (8+2)	168.5	63	6000	6.60
PMC-200-140P0543R-AM	771.20.121.84	200	14 (12+2)	208.5	63	4000	9.60
PMC-250-180P0543R-AM	771.20.121.94	250	18 (16+2)	258.5	63	3000	15.00

Spare parts on page 88

Assembly manual on page 89

Adjusting manual on page 92

Indexable inserts for **PMC43OP**

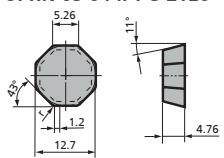
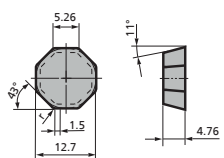
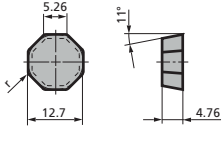
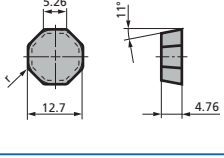
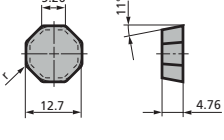
INSERT	TYPE	GRADE	K													H	S	P	SPK ORDER NR.											
			GJL			GJS			ADI		SI GJS		GJV			HARD STEEL CHILLED CAST IRON DIE CASTING	HRSA	STEEL												
			EN-GJL 150	EN-GJL 200	EN-GJL 250	EN-GJL 300	EN-GJL 350	EN-GJS 400-15	EN-GJS 500-7	EN-GJS 600-3	EN-GJS 700-2	EN-GJS 800-2	EN-GJS 800-8	EN-GJS 1000-5	EN-GJS 1200-2				EN-GJS 1400-0	EN-GJS 450-18	EN-GJS 500-14	EN-GJS 600-10	EN-GJV 300	EN-GJV 350	EN-GJV 400	EN-GJV 450	EN-GJV 500			
OPHN 05 04 .. T-S Z120 	OPHN 050404 E00040 - 43Z120	SC 60	◆	◆	◆	◆	◆	◆	◆	◆	◆	◆					◆	◆	◆											46.75.011.70.6
OPHN 05 04 .. T-S Z150 	OPHN 050404 T-S 43Z150	WBN 115	◆	◆	◆	◆	◆	◆	◆	◆	◆	◆					◆	◆	◆										12.68.001.03.0	
		WBN 101	◆	◆	◆	◆	◆	◆	◆	◆	◆	◆					◆	◆	◆										20.68.003.20.1	
OPHN 05 04 .. T01020 	OPHN 050408 T01020	SL 808	◆	◆	◆	◆	◆	◆	◆	◆	◆	◆					◆	◆	◆										17.72.005.20.1	
OPHN 05 04 .. T01020 	OPHN 050412 T01020	SL 500	◆	◆	◆	◆	◆										◆	◆	◆										36.72.001.20.0	
	OPHN 050412 T01020	SL 808	◆	◆	◆	◆	◆	◆	◆	◆	◆	◆					◆	◆	◆										17.72.001.20.1	
	OPHN 050412 T01020	SL 854 C	◆	◆	◆	◆	◆	◆	◆	◆	◆	◆	◆	◆	◆	◆	◆	◆	◆	◆	◆	◆	◆	◆	◆	◆	◆	◆	17.72.001.20.9	
	OPHN 050412 E00040	SC 60	◆	◆	◆	◆	◆	◆	◆	◆	◆	◆					◆	◆	◆										46.75.012.70.6	
OPHN 05 04 ZZ T01020 	OPHN 0504ZZ T01020	SL 500	◆	◆	◆	◆	◆										◆	◆	◆										36.72.002.20.0	

ISO application group

K ■ Cast iron

H ■ Hard materials

S ■ HSRA

P ■ Steel

Main application ◆

Secondary application ◆

Face-milling cutter **PMCM43OP**

Finish milling

3.2
1.6



$v_c = 700 - 1000 \text{ m/min}$
 $f_t = 0.12 - 0.20 \text{ mm}$
 $a_p = 0.2 - 1.5 \text{ mm}$

Axial rake angle $\gamma_a = +4^\circ$
Radial rake angle γ_r depending on $\theta = 0^\circ$
Connection dimensions as per DIN 8030

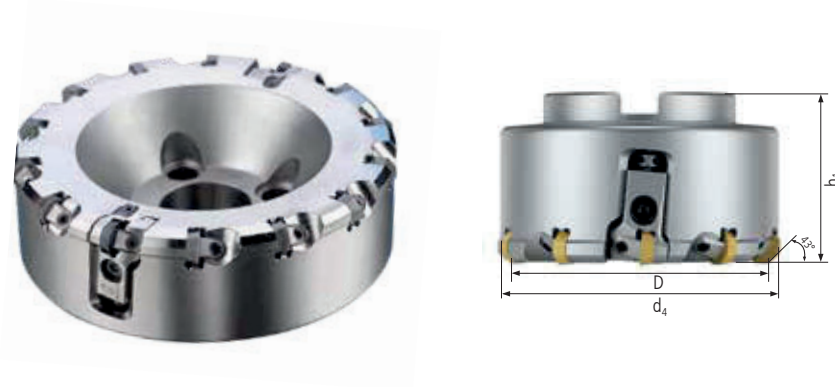
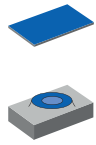

Type	SPK order no.	Dimensions					
		D	Z	d_1	h_1	n_{max} (rpm)	Weight (kg)
Standard pitch							
PMCM-100-100P0543R-AM	771.20.521.54	100	10 (9+1)	108.5	63	8000	2.80
PMCM-125-120P0543R-AM	771.20.521.64	125	12 (10+2)	133.5	63	8000	4.20
PMCM-160-140P0543R-AM	771.20.521.74	160	14 (12+2)	168.5	63	6000	6.50
PMCM-200-200P0543R-AM	771.20.521.84	200	20 (18+2)	208.5	63	4000	9.50
PMCM-250-240P0543R-AM	771.20.521.94	250	24 (21+3)	258.5	63	3000	14.80
Wide pitch							
PMCM-160-100P0543R-AM	771.20.221.74	160	10 (8+2)	168.5	63	6000	6.60
PMCM-200-140P0543R-AM	771.20.221.84	200	14 (12+2)	208.5	63	4000	9.60
PMCM-250-180P0543R-AM	771.20.221.94	250	18 (16+2)	258.5	63	3000	15.00

Spare parts on page 88

Assembly manual on page 89

Adjusting manual on page 92

Indexable inserts for **PMCM43OP**

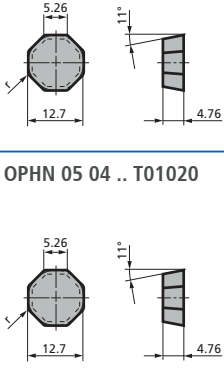
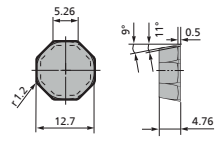
INSERT	TYPE	GRADE	K													H	S	P	SPK ORDER NR.											
			GJL			GJS			ADI		SI GJS		GJV																	
			EN-GJL 150	EN-GJL 200	EN-GJL 250	EN-GJL 300	EN-GJL 350	EN-GJS 400-15	EN-GJS 500-7	EN-GJS 600-3	EN-GJS 700-2	EN-GJS 800-2	EN-GJS 800-8	EN-GJS 1000-5	EN-GJS 1200-2	EN-GJS 1400-0	EN-GJS 450-18	EN-GJS 500-14	EN-GJS 600-10	EN-GJV 300	EN-GJV 350	EN-GJV 400	EN-GJV 450	EN-GJV 500	HARD STEEL	CHILLED CAST IRON	DIE CASTING	HSRA	STEEL	
OPHN 05 04 .. T01020	OPHN 050408 T01020	SL 808	◆	◆	◆	◆	◆	◆	◆	◆	◆						◆	◆	◆											17.72.005.20.1
	OPHN 050412 T01020	SL 500	◆	◆	◆	◆											◆	◆	◆											36.72.001.20.0
	OPHN 050412 T01020	SL 808	◆	◆	◆	◆	◆	◆	◆	◆	◆							◆	◆	◆										17.72.001.20.1
	OPHN 050412 T01020	SL 854 C	◆	◆	◆	◆	◆	◆	◆	◆	◆	◆	◆	◆	◆	◆	◆	◆	◆	◆	◆	◆	◆	◆	◆					17.72.001.20.9
	OPHN 050412 T-S-8XR300W9	WBN 115	◆	◆	◆	◆	◆	◆	◆	◆	◆						◆	◆	◆											12.68.003.20.0
		WBN 101	◆	◆	◆	◆	◆	◆	◆	◆	◆	◆						◆	◆	◆										20.68.003.20.1

ISO application group

K ■ Cast iron	H ■ Hard materials	S ■ HSRA	P ■ Steel	Main application ◆	Secondary application ◆
---	--	--	--	---	---

Face-milling cutter **PPC88SP** with finishing cartridge

Finish milling

3.2
▽
0.8
▽



stable / unstable components

$v_c = 600 - 1200 \text{ m/min}$
 $f_t = 0.12 - 0.30 \text{ mm}$
 $a_p = 0.20 - 0.80 \text{ mm}$

Axial rake angle $\gamma_a = +7^\circ$
Radial rake angle $\gamma_r = +2^\circ$
Connection dimensions as per DIN 8030



WITH FINISHING CARTRIDGE

Type	SPK order no.	Dimensions					
		D	Z	d_4	h_1	n_{max} (rpm)	Weight (kg)
Standard pitch							
PPC-080-06SP0988R-AM	771.20.411.42	80	6	81	63	8500	0.80
PPC-100-08SP0988R-AM	771.20.411.52	100	8	101	63	6400	1.10
PPC-125-12SP0988R-AM	771.20.411.62	125	12	126	63	5200	1.70
PPC-160-14SP0988R-AM	771.20.411.72	160	14	161	63	4000	2.50
PPC-200-20SP0988R-AM	771.20.411.82	200	20	201	63	3200	4.10
PPC-250-24SP0988R-AM	771.20.411.92	250	24	251	63	2600	6.60
PPC-315-28SP0988R-AM	771.20.411.02	315	28	316	80	2100	12.10
Wide pitch							
PPC-080-04SP0988R-AM	771.20.111.42	80	4	81	63	8500	0.80
PPC-100-06SP0988R-AM	771.20.111.52	100	6	101	63	6400	1.10
PPC-125-08SP0988R-AM	771.20.111.62	125	8	126	63	5200	1.60
PPC-160-10SP0988R-AM	771.20.111.72	160	10	161	63	4000	2.40
PPC-200-14SP0988R-AM	771.20.111.82	200	14	201	63	3200	3.90
PPC-250-18SP0988R-AM	771.20.111.92	250	18	251	63	2600	6.50
PPC-315-20SP0988R-AM	771.20.111.02	315	20	316	80	2100	12.30

Spare parts on page 90

Assembly manual on page 91

Adjusting manual on page 92

Indexable inserts for **PPC88SP**

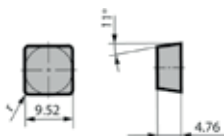
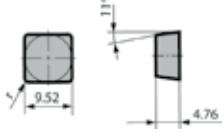
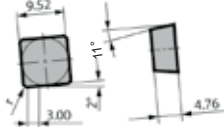
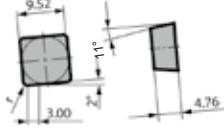
INSERT	TYPE	GRADE	K															H	S	P	SPK ORDER NR.							
			GJL			GJS			ADI			SI GJS			GJV			HARD STEEL CHILLED CAST IRON DIE CASTING HSRA STEEL										
			EN-GJL 150	EN-GJL 200	EN-GJL 250	EN-GJL 300	EN-GJL 350	EN-GJS 400-15	EN-GJS 500-7	EN-GJS 600-3	EN-GJS 700-2	EN-GJS 800-2	EN-GJS 800-8	EN-GJS 1000-5	EN-GJS 1200-2	EN-GJS 1400-0	EN-GJS 450-18				EN-GJS 500-14	EN-GJS 600-10	EN-GJV 300	EN-GJV 350	EN-GJV 400	EN-GJV 450	EN-GJV 500	
For 88° cartridges																												
 SPCN 09 04 .. T	SPCN 090408 T01020	SL 500	◆	◆	◆	◆																						36.12.427.20.0
		SL 506	◆	◆	◆	◆																						19.12.427.20.1
		LKM 840	◆	◆	◆	◆	◆	◆	◆	◆	◆	◆					◆	◆	◆								◆	23.12.427.20.2
		SL 808	◆	◆	◆	◆	◆	◆	◆	◆	◆	◆					◆	◆	◆									17.12.427.20.1
 SPCN 09 04 .. E	SPCN 090408 E	TS 5115	◆	◆	◆	◆	◆										◆	◆	◆								◆	50.19.000.40.8
 SPCN 09 04 .. T - 88Z300	SPCN 090408 T - 88Z300	SL 506	◆	◆	◆	◆																						19.12.429.20.1
	SPCN 090408 T - S88Z300	WBN 101	◆	◆	◆	◆																						20.18.002.20.1
		WBN 115	◆	◆	◆	◆																						12.18.002.20.0
 SPCN 09 04 .. E - 88Z300	SPCN 090408 E - 88Z300	TS 5115	◆	◆	◆	◆	◆																				◆	50.19.002.40.8

ISO application group

K ■ Cast iron

H ■ Hard materials

S ■ HSRA

P ■ Steel

Main application ◆

Secondary application ◇

Face-milling cutter **PPCM88SP** with fine-finishing cartridge 90°

Finish milling

3.2
▽
0.5
▽



stable / unstable components

$v_c = 600 - 1200 \text{ m/min}$
 $f_t = 0.12 - 0.30 \text{ mm}$
 $a_p = 0.20 - 0.80 \text{ mm}$

Axial rake angle $\gamma_a = +7^\circ$
Radial rake angle $\gamma_r = +2^\circ$
Connection dimensions as per DIN 8030

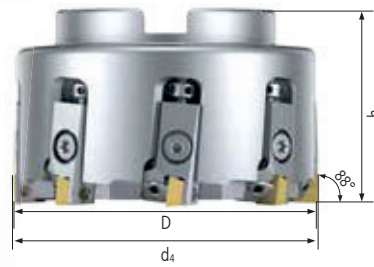

WITH FINE-FINISHING CARTRIDGE

Type	SPK order no.	Dimensions					
		D	Z	d ₄	h ₁	n _{max} (rpm)	Weight (kg)
Standard pitch							
PPCM-080-06SP0988R-AM	771.20.511.42	80	5+1	81	63	8500	0.80
PPCM-100-08SP0988R-AM	771.20.511.52	100	7+1	101	63	6400	1.10
PPCM-125-12SP0988R-AM	771.20.511.62	125	10+2	126	63	5200	1.70
PPCM-160-14SP0988R-AM	771.20.511.72	160	12+2	161	63	4000	2.50
PPCM-200-20SP0988R-AM	771.20.511.82	200	18+2	201	63	3200	4.20
PPCM-250-24SP0988R-AM	771.20.511.92	250	21+3	251	63	2600	6.60
PPCM-315-28SP0988R-AM	771.20.511.02	315	24+4	316	80	2100	12.10
Wide pitch							
PPCM-080-04SP0988R-AM	771.20.211.42	80	3+1	81	63	8500	0.80
PPCM-100-06SP0988R-AM	771.20.211.52	100	5+1	101	63	6400	1.10
PPCM-125-08SP0988R-AM	771.20.211.62	125	7+1	126	63	5200	1.60
PPCM-160-10SP0988R-AM	771.20.211.72	160	8+2	161	63	4000	2.40
PPCM-200-14SP0988R-AM	771.20.211.82	200	12+2	201	63	3200	3.90
PPCM-250-18SP0988R-AM	771.20.211.92	250	16+2	251	63	2600	6.50
PPCM-315-20SP0988R-AM	771.20.211.02	315	18+2	316	80	2100	12.00

Spare parts on page 90

Assembly manual on page 91

Adjusting manual on page 92

Indexable inserts for **PPCM88SP**

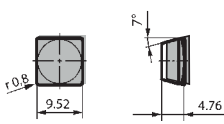
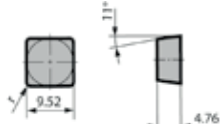
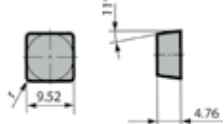
INSERT	TYPE	GRADE	K													H	S	P	SPK ORDER NR.											
			GJL			GJS			ADI		SI GJS		GJV																	
			EN-GJL 150	EN-GJL 200	EN-GJL 250	EN-GJL 300	EN-GJL 350	EN-GJS 400-15	EN-GJS 500-7	EN-GJS 600-3	EN-GJS 700-2	EN-GJS 800-2	EN-GJS 800-8	EN-GJS 1000-5	EN-GJS 1200-2	EN-GJS 1400-0	EN-GJS 500-18	EN-GJS 600-10	EN-GJV 300	EN-GJV 350	EN-GJV 400	EN-GJV 450	EN-GJV 500	HARD STEEL	CHILLED CAST IRON	DIE CASTING	HSRA	STEEL		
For 90° cartridges																														
SCHX 09 04 .. T 	SPCHX 090408 T113	TS 5115	◆	◆	◆	◆																							◆	50.19.001.99.8
		WBN 101	◆	◆	◆	◆																								20.18.001.99.1
		WBN 115	◆	◆	◆	◆																								12.18.001.99.0
For 88° cartridges																														
SPCN 09 04 .. T 	SPCN 090408 T01020	SL 500	◆	◆	◆	◆																								36.12.427.20.0
		SL 506	◆	◆	◆	◆																								19.12.427.20.1
		LKM 840	◆	◆	◆	◆	◆	◆	◆	◆	◆	◆					◆	◆	◆									◆		23.12.427.20.2
		SL 808	◆	◆	◆	◆	◆	◆	◆	◆	◆	◆					◆	◆	◆											17.12.427.20.1
SPCN 09 04 .. E 	SPCN 090408 E	TS 5115	◆	◆	◆	◆																							◆	50.19.000.40.8

ISO application group

K ■ Cast iron

H ■ Hard materials

S ■ HSRA

P ■ Steel

Main application ◆

Secondary application ◇

Face-milling cutter **MFS88SN**

Finish milling

6.3
3.2
0.8



AWN
stable / unstable components

$v_c = 500 - 800 \text{ m/min}$
 $f_r = 0.10 - 0.25 \text{ mm}$
 $a_p = 0.1 - 1.0 \text{ mm}$

Axial rake angle $\gamma_a = -7^\circ$
Radial rake angle $\gamma_r = -8^\circ$
Connection dimensions as per DIN 8030

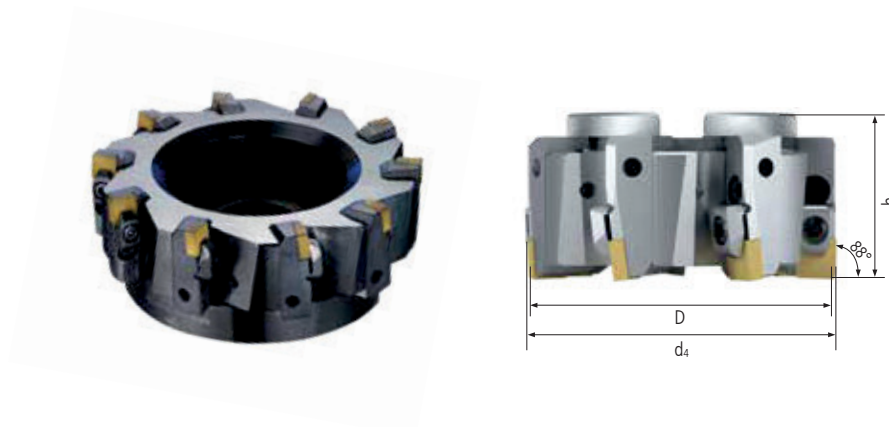

Type	SPK order no.	Dimensions					
		D	Z	d ₄	h ₁	n _{max} (rpm)	Weight (kg)
MFS 080-06-88 M4	772.91.537.93	80	5 + 1	81	53	6700	1.10
MFS 100-07-88 M4	772.91.538.93	100	6 + 1	101	53	6000	1.70
MFS 125-08-88 M4	772.91.539.93	125	7 + 1	126	66	5400	3.40
MFS 160-10-88 M4	772.91.540.93	160	9 + 1	161	66	4700	5.70
MFS 200-12-88 M4	772.91.541.93	200	11 + 1	201	66	4200	9.00
MFS 250-16-88 M4	772.91.543.93	250	15 + 1	251	66	3800	16.50

88 F4 SN  772.95.536.03	Tightening torque 5 Nm  70.91.11.468.0	Torx blade ISR20  70.91.55.210.0	
O Z4 SN  772.95.538.03	Tightening torque 5 Nm  70.91.11.468.0	Torx blade ISR20  70.91.55.210.0	
Tightening torque 5 Nm  70.91.50.615.0	 70.91.54.033.0	Torx blade ISR20  70.91.55.210.0	SW 4  33.60.0.911.004.0

Assembly and adjusting manual on page 93

Indexable inserts for **MFS88SN**

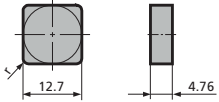
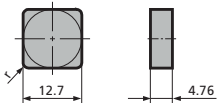
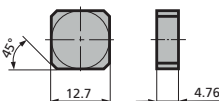
INSERT	TYPE	GRADE	K														H	S	P	SPK ORDER NR.											
			GJL				GJS				ADI		SI GJS		GJV																
			EN-GJL 150	EN-GJL 200	EN-GJL 250	EN-GJL 300	EN-GJL 350	EN-GJS 400-15	EN-GJS 500-7	EN-GJS 600-3	EN-GJS 700-2	EN-GJS 800-2	EN-GJS 800-8	EN-GJS 1000-5	EN-GJS 1200-2	EN-GJS 1400-0	EN-GJS 450-18	EN-GJS 500-14	EN-GJS 600-10	EN-GJV 300	EN-GJV 350	EN-GJV 400	EN-GJV 450	EN-GJV 500	HARD STEEL	CHILLED CAST IRON	DIE CASTING	HSRA	STEEL		
SNCN 1204 .. T 	SNCN 120404 T00520	SL 500	◆	◆	◆	◆	◆										◆	◆	◆												36.10.431.03.0
		SL 808	◆	◆	◆	◆	◆	◆	◆	◆	◆	◆					◆	◆	◆												17.10.409.03.1
		SL 858 C	◆	◆	◆	◆	◆	◆	◆	◆	◆	◆	◆	◆	◆	◆	◆	◆	◆	◆	◆	◆	◆	◆	◆						21.10.431.03.1
SNGN 1204 .. T 	SNGN 120408 T01020	SL 500	◆	◆	◆	◆	◆										◆	◆	◆											36.10.009.20.0	
		SL 808	◆	◆	◆	◆	◆	◆	◆	◆	◆	◆					◆	◆	◆												17.10.009.20.1
		SL 854 C	◆	◆	◆	◆	◆	◆	◆	◆	◆	◆	◆	◆	◆	◆	◆	◆	◆	◆	◆	◆	◆	◆	◆						17.10.009.20.9
		LKM 840	◆	◆	◆	◆	◆	◆	◆	◆	◆	◆	◆				◆	◆	◆									◆			23.10.009.20.2
	SNGN 120412 T01020	SL 500	◆	◆	◆	◆	◆											◆	◆	◆											36.10.058.20.0
		SL 808	◆	◆	◆	◆	◆	◆	◆	◆	◆	◆	◆					◆	◆	◆											17.10.058.20.1
		SL 854 C	◆	◆	◆	◆	◆	◆	◆	◆	◆	◆	◆	◆	◆	◆	◆	◆	◆	◆	◆	◆	◆	◆	◆						21.10.058.20.1
		SL 858 C	◆	◆	◆	◆	◆	◆	◆	◆	◆	◆	◆	◆	◆	◆	◆	◆	◆	◆	◆	◆	◆	◆	◆						17.10.058.20.9
	LKM 840	◆	◆	◆	◆	◆	◆	◆	◆	◆	◆	◆	◆				◆	◆	◆								◆			23.10.058.20.2	
SNCN 1204 ZN T 	SNCN 1204 ZN T00520	SL 500	◆	◆	◆	◆	◆	◆	◆	◆	◆	◆					◆	◆	◆												36.10.409.03.0
		SL 808	◆	◆	◆	◆	◆	◆	◆	◆	◆	◆	◆				◆	◆	◆												17.10.409.03.1
		SL 854 C	◆	◆	◆	◆	◆	◆	◆	◆	◆	◆	◆	◆	◆	◆	◆	◆	◆	◆	◆	◆	◆	◆	◆						17.10.409.03.9
		LKM 840	◆	◆	◆	◆	◆	◆	◆	◆	◆	◆	◆				◆	◆	◆									◆			23.10.409.03.2

ISO application group

K ■ Cast iron

H ■ Hard materials

S ■ HSRA

P ■ Steel

Main application ◆

Secondary application ◆

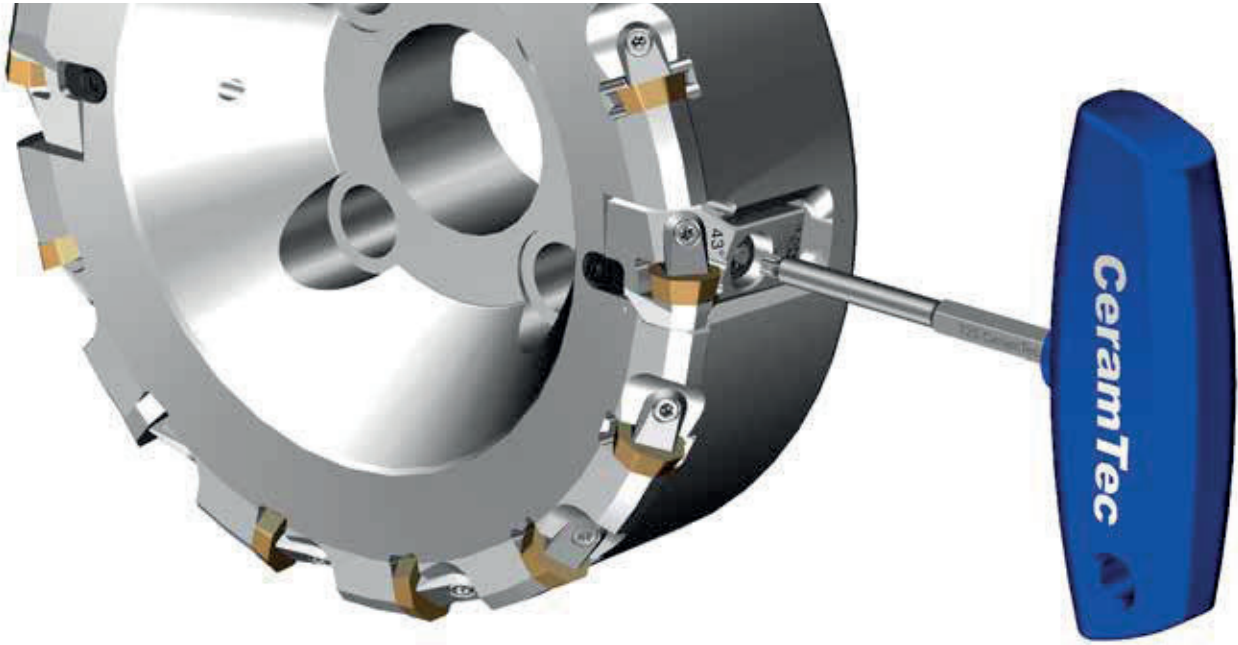

Tightening torques

Overview of tightening torques for insert mounting	
Hole clamping	5 Nm*
Wedge clamping	3.5 - 5 Nm*
Wedge clamping in cartridges	3.5 Nm*

* The exact value for the tightening torque can be found in the catalog section on page 28 - 82.

Overview of tightening torques for screw-on milling cutters, type PFK-RP	
Diameter 20 mm	40 Nm
Diameter 25 mm	60 Nm
Diameter 32 mm	80 Nm
Diameter 40 mm	80 Nm

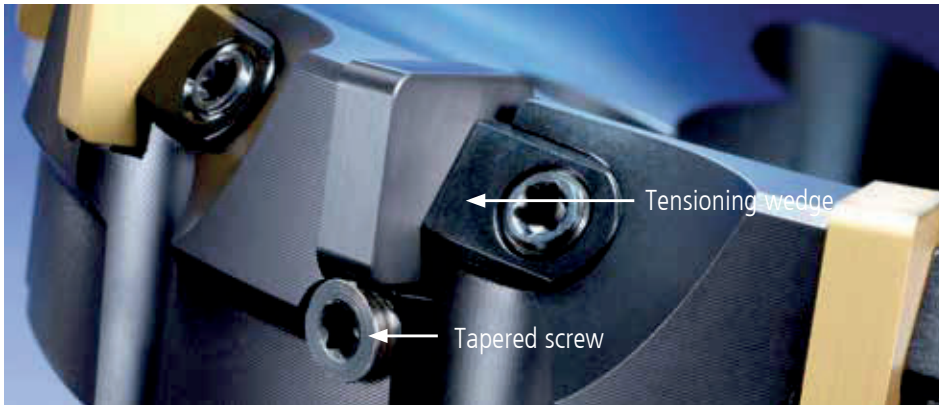

i Fine adjustment

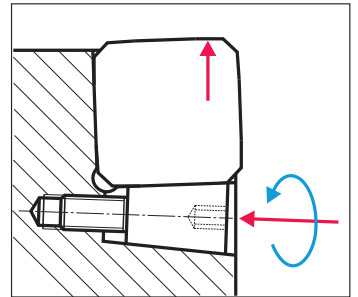

Fine adjustment by means of tapered screw

1. Position all tapered screws flush with the outside diameter of the milling cutter
2. Place inserts in the insert seat and hand-tighten with the clamping wedges
3. Screw in tapered screws until slight resistance is felt
4. Place the milling cutter in an adjuster unit and set all indexable inserts flat one by one in clockwise rotation of the tapered screw in the μm range
5. Tighten clamping wedges with a torque of 5 Nm

Spare parts

PMC43^{OP} / PMCM43^{OP}



Fine finishing cartridge for PMCM type

45° cutting edge angle
SPK order no. 739.11.002.14



Finishing cartridge for PMC type

43° cutting edge angle
SPK order no. 739.11.001.14

1 Wedge and double threaded screw are included in the scope of supply of cartridges!

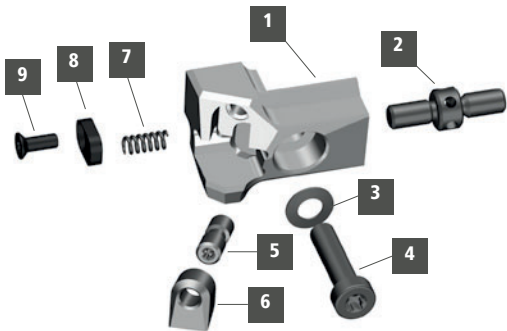

		Name	SPK order no.
2		Adjustment screw	70.91.50.917.0
3		Belleville washer	70.91.55.718.0
4		Clamp screw	70.91.50.916.0
5		Double-threaded screws	70.91.50.328.0
6		Wedge	70.91.55.677.0
7		Compression spring	70.91.55.717.0
8		Cover plate	70.91.55.716.0
9		Countersunk screw	60.09.63.002.0

Torx bit 25	SW 2	Cross-handle	Torx 9
70.91.55.710.0	70.91.55.725.0	70.91.55.706.0	70.91.55.218.0

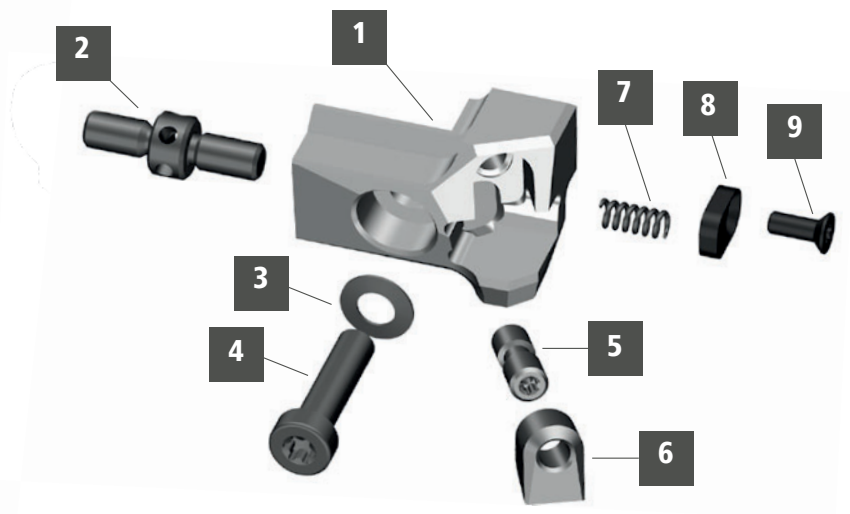

1	Cartridge
2	Setting screw
3	Disc spring
4	Clamp screw
5	Double-threaded screws
6	Wedge
7	Compression spring
8	Cover plate
9	Countersunk screw

Turn adjusting screw (2) in cartridge bottom side up to the center of the bore belt.

Insert cartridge into prismatic guide and adjusting screw (2) in base frame until cartridge head protrudes slightly.

Fix cartridge slightly with clamp screw (4) and disc spring (3).

Mount compression spring (7) and cover plate (8) with countersunk screw (9).

Screw in the double threaded screw (5) into the clamping wedge (6) and screw it into the cartridge with Allen key, SW2.

Spare parts

PPC88SP / PPCM88SP



Fine finishing cartridge for PPCM type

90° cutting edge angle
SPK order no. 739.01.003.13

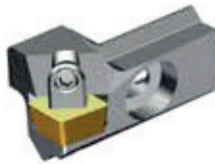

Finishing cartridge for PPC / PPCM type

88° cutting edge angle
SPK order no. 739.01.004.13

1 Wedge and double threaded screw are included in the scope of supply of cartridges!

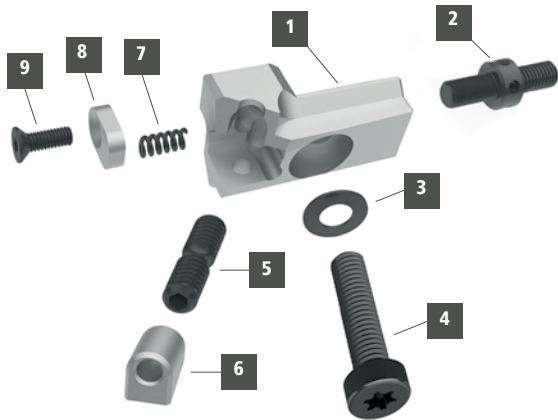

		Name	SPK order no.
2		Adjustment screw	70.91.50.917.0
3		Belleville washer	70.91.55.718.0
4		Clamp screw	70.91.50.916.0
5		Double-threaded screws	70.91.50.648.0
6		Wedge	70.91.55.696.0
7		Compression spring	70.91.55.717.0
8		Cover plate	70.91.55.716.0
9		Countersunk screw	60.09.63.002.0

<p>Torx bit 25</p> <p>70.91.55.710.0</p>	<p>SW 2</p> <p>70.91.55.725.0</p>	<p>Cross-handle</p> <p>70.91.55.706.0</p>	<p>Torx 9</p> <p>70.91.55.218.0</p>
---	--	--	--



1	Cartridge
2	Adjustment screw
3	Disc spring
4	Clamp screw
5	Double-threaded screws
6	Wedge
7	Compression spring
8	Cover plate
9	Countersunk screw

Turn adjusting screw (2) in cartridge bottom side up to the center of the bore belt.

Insert cartridge into prismatic guide and adjusting screw (2) in base frame until cartridge head protrudes slightly.

Fix cartridge slightly with clamp screw (4) and disc spring (3).

Mount compression spring (7) and cover plate (8) with countersunk screw (9).

Screw in the double threaded screw (5) into the clamping wedge (6) and screw it into the cartridge with Allen key, SW2.

Place the milling cutter equipped with cartridges and inserts on the adjuster unit.

Slightly tighten the cartridge clamping screw.

Set all inserts at the same height using the cartridge adjusting screw (Figures A + B):

- Coarse adjustment of the cartridges over the back side of the milling cutter (Fig. A).
- Fine adjustment of the cartridges over the side of the milling cutter (Fig. B).

Height measuring point for PPCM type milling cutter with fine finishing cartridge (Fig. C):

- For 88° finishing cartridges, the height measurement point is at the cutting edge of the insert.
- For 90° fine finishing cartridges, the height measurement point is in the center of the cutting edge.

Adjust the fine finishing cartridges 0.03 - 0.05 mm higher than the finishing cartridges.

Tighten clamping screw with 5 Nm (Fig. E).

Height measuring point for PMC/PMCM type milling cutter with fine finishing cartridge (Fig. D):

- For 43° finishing cartridges, the height measurement point is at the cutting edge of the insert.
- For 45° fine finishing cartridges, the height measurement point is in the center of the cutting edge.

Set the cartridges 0.03 - 0.05 mm higher than the inserts in the fixed insert seats.

Tighten clamping screw with 5 Nm (Fig. E).

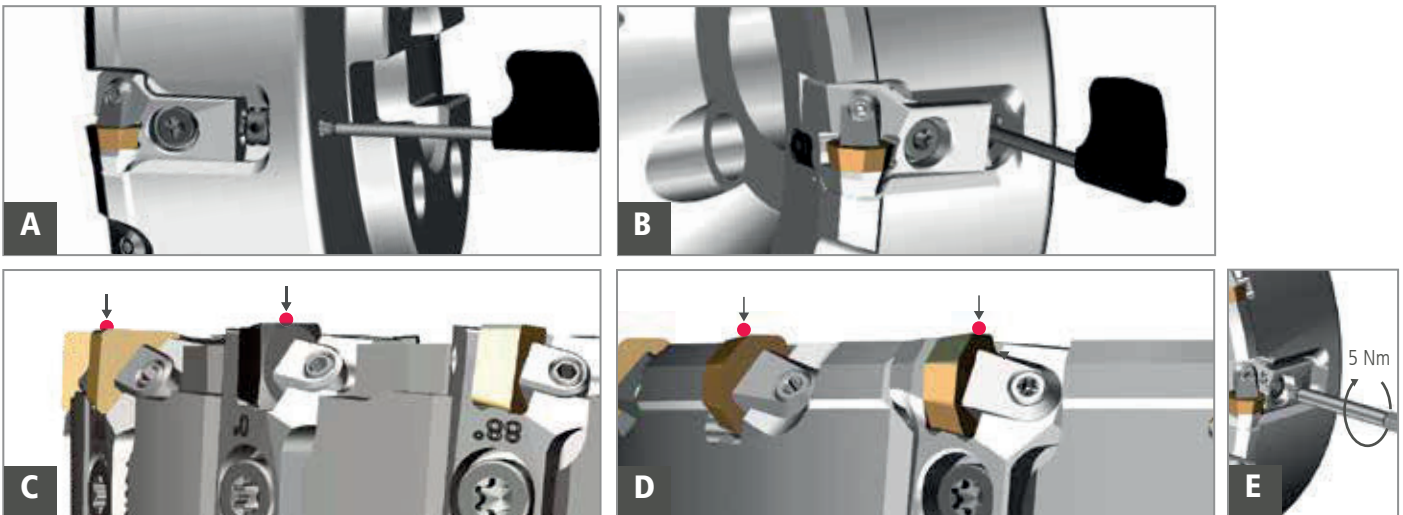

FINE FINISHING WITH PPC / PPCM AND PMC / PMCM

The milling cutters produce excellent surface finishes with an Ra value of 0.5 µm with the following setting:

- Adjust the axial run-out of all cartridges.
- Adjust the fine finishing cartridges by 0.03 - 0.05 mm higher than the finishing cartridges (PPC/PPCM type milling cutters).

For PMC/PMCM type milling cutters, adjust the fine finishing cartridges 0.03 - 0.05 mm higher than the inserts in the fixed insert seats. With this setting, the inserts with a cutting

edge angle of 90° (milling cutter types PPC/PPCM) and 45° (milling cutter types PMC/PMCM), with their special wiper fine-finishing geometry, produce the surface quality, while the inserts in the finishing cartridges (milling cutter types PPC/PPCM), or fixed insert seats (milling cutter types PMC/PMCM) perform the removal work in the feed direction.

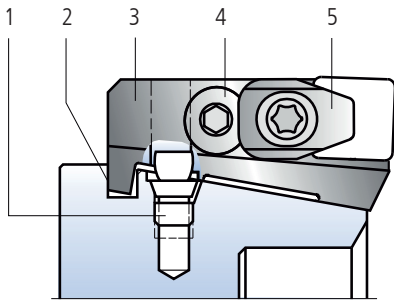

Allen key SW 4 for clamping screw - 4 -
33.60.0.911.004.0

Screwdriver Torx 20 for adjusting bolt -1-
70.91.55.210.0



1. Screw adjusting bolt -1- with screwdriver Torx 20 into the base frame. After the conical surfaces touch the jacket, loosen approx. 2 turns counterclockwise.
2. Place cartridge - 3 - on the base frame's radial groove flank - 2 - and press on it. Tighten clamping screw - 4 - with screwdriver SW4 (15 Nm).
3. Apply adjusting bolt -1- slightly with a screwdriver by turning clockwise.
4. Install clamping element - 5 -.
5. Press the milling insert into the insert seat and tighten the clamping element screw hand-tight (5Nm).

6. After installing all cartridges, determine the highest axial point and put it forward by approx. 0.01 mm by turning the adjusting bolt -1- clockwise with a screwdriver.
7. The remaining cartridges are adjusted below the highest axial point determined in point 6. It should be noted that after the μm -precise adjustment, the pre-load is taken from the adjusting bolt -1-. This is achieved by a relief rotation of the adjusting bolt counterclockwise and reapplication without pre-load.

Reset cartridges to initial position

Loosen the adjusting bolt counterclockwise with a screwdriver, then return the cartridge to the clearance-free radial groove flank - 2 - (tap with copper bolt on the radial groove flank -2-). Then adjust the cartridges according to point 6 and 7 to axial run-out.



Designation system for ceramic inserts for milling as per ISO 1832

V	35°		
D	55°		
E	75°		
C	80°		
M	86°		
K	55°		
B	82°		
A	85°		
R			
S	90°		
T	60°		
W	80°		
L			
P	108°		
H	120°		
O	135°		

Insert shape

N	0°
A	3°
B	5°
C	7°
P	11°
D	15°
E	20°
F	25°
G	30°
O	↓

Clearance angle, which requires particular specifications.

Clearance angle α_n

Inner circle										Inner circle	
d mm	RC, RN S	O 135°	H 120°	T 60°	C 80°	E 75°	D 55°	V 35°	W 80°	d mm	RB (Type MO)
3.97				06						6.0	06
5.56				09						7.0	07
6.35				11	06		07			8.0	08
9.52	09			16	09		11	16	06	9.0	09
10.00							12			10.0	10
12.70	12	05		22	12	13	15	22	08	12.0	12
13.50	13	05						09			
15.88	15	06	09	27	16					16.0	16
16.20			10								
16.50		06									
19.05	19			33						20.0	20
25.40	25			44						25.0	25

Insert size

S

N

C

N

12

Tolerances

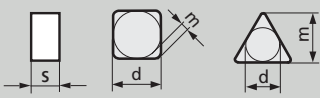

* Permissible deviation for insert shape, depending on the insert size

	S = ± mm	d = ± mm	m = ± mm	Inner circle	Tolerance class			
				d mm	J, K, L, M	U	M, N	U
					d = ± mm		m = ± mm	
A	0.025	0.025	0.005					
C	0.025	0.025	0.013					
E	0.025	0.025	0.025					
F	0.025	0.013	0.005	3.97				
G	0.130	0.025	0.025	5.56	0.05	0.08	0.08	0.13
H	0.025	0.013	0.013	6.35				
J	0.025	0.05-0.13*	0.005	9.52				
K	0.025	0.05-0.13*	0.013	12.70	0.08	0.13	0.13	0.2
L	0.025	0.05-0.13*	0.025	15.88				
M	0.130	0.05-0.13*	0.08-0.18*	19.05	0.1	0.18	0.15	0.27
U	0.130	0.08-0.25*	0.13-0.38*	25.40	0.13	0.25	0.18	0.38

Insert type

N		T	
R		Q	
F		U	
A		B	
M		H	
G		C	
W		J	

X Special design

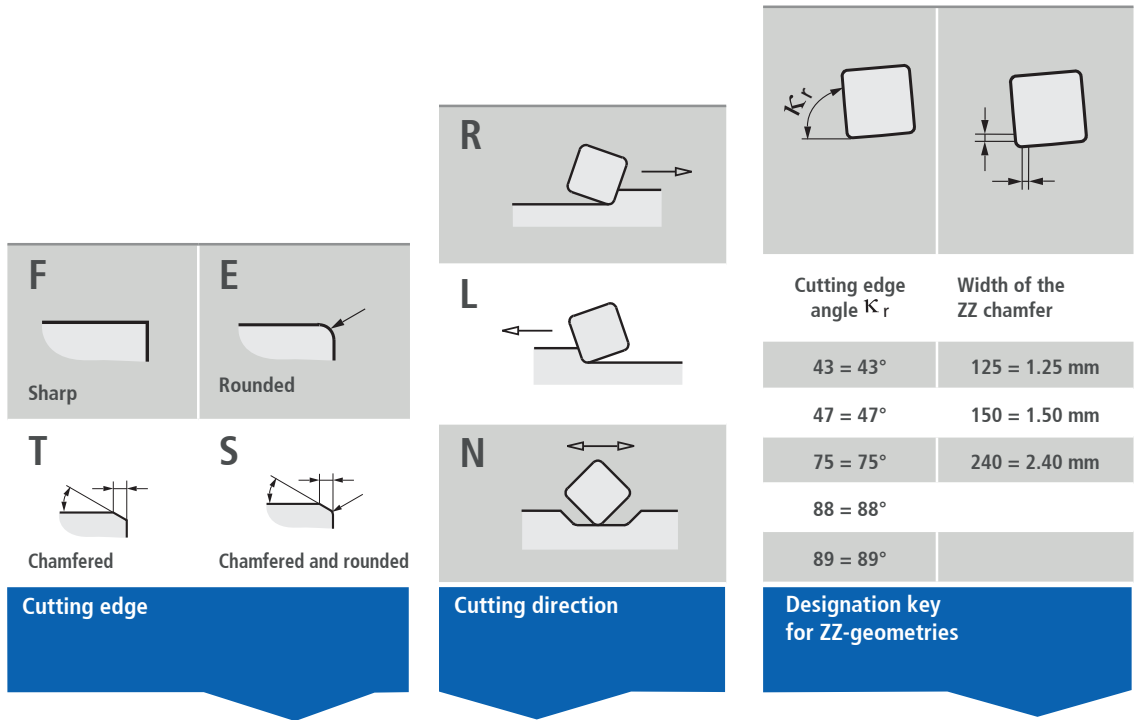

04 ZN F N 01020 - 89Z240

Insert thickness

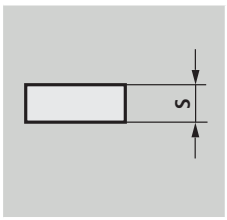

01	1.59
02	2.38
03	3.18
T3	3.97
04	4.76
05	5.56
06	6.35
07	7.94
09	9.52
12	12.70

Corner radius / face cutting

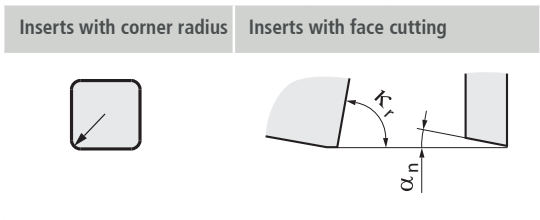

Inserts with corner radius		Inserts with face cutting		Cutting edge angle of the major cutting edge κ_r	Clearance angle α_n
Code	Value	Code	Value		
00	RN, RC				
M0	RB				
02	0.2				
04	0.4				
08	0.8	A	45°	N	0°
12	1.2	D	60°	C	7°
16	1.6	E	75°	P	11°
24	2.4	F	85°	D	15°
32	3.2	P	90°	E	20°
40	4.0	Z	Special	F	25°

Chamfer size

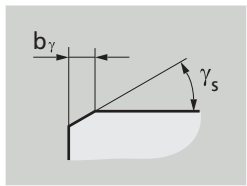











Chamfer width b_γ in 1/100 mm and angle γ_s without degree symbol

e.g.
 $0.10 \times 20^\circ = 01020$
 $0.05 \times 20^\circ = 00520$

Table of Contents

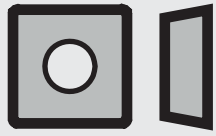
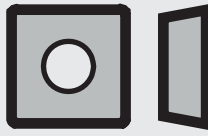
Ceramic inserts for milling

HDGX  Page 99	HNGX  Page 99	ODHW, OEHX, OPHX  Page 99 - 100	ONHQ  Page 100
OPHN  Page 100	RPGN  Page 101	RNGN, RNCX  Page 101	SCHX, SDCN, SECN, SOCN, SPCN, SPGN, SPHN, SPKN  Page 101 - 107
SNCN, SNFN, SNGN, SNHX  Page 102 - 105	SDHW, SEHW  Page 101 - 102	SPHX  Page 106 - 107	TNCN  Page 107 - 108
WPHX  Page 108			



INSERT	TYPE	GRADE	SPK ORDER NO.
HDGX 10 05 .. T 	HDGX 100512 T01020	SL 808	17.62.014.20.1
	HNGX 100512 T02030	SL 808	17.62.014.52.1
HNGX 10 05 .. T 	HNGX 100512 T01020	SL 500	36.60.123.20.0
		SL 808	17.60.123.20.1
	HNGX 100516 T01020	SL 500	36.60.124.20.0
		SL 808	17.60.124.20.1
HNGX 10 05 16 T - 47Z125 	HNGX 100516 T01020 - 47Z125	SL 500	36.60.120.20.0
	HNGX 100516 T03020 - 47Z125	SL 808	17.60.120.23.1
ODHW 05 04 .. T 	ODHW 050408 T 01020	SL 500	36.76.001.20.0
	ODHW 050412 T 01020	SL 500	36.76.002.20.0
ODHW 06 05 .. T 	ODHW 060516 T 01020	SL 500	36.76.003.20.0

Ceramic inserts for milling

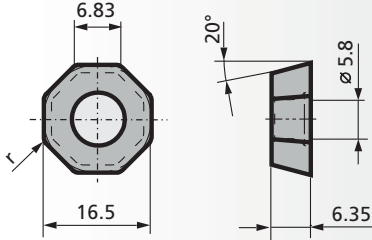
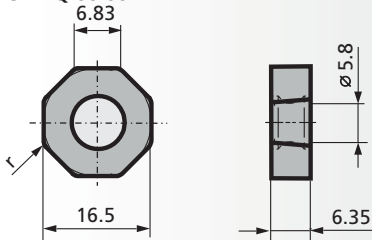
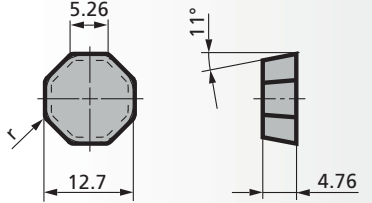
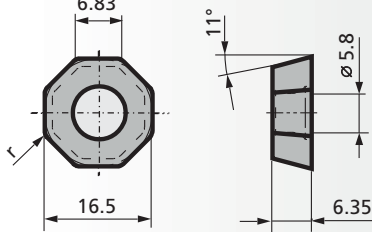
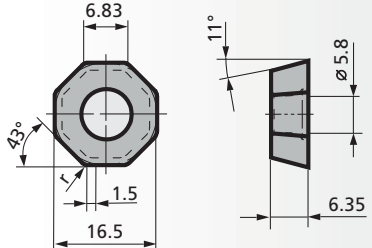
INSERT	TYPE	GRADE	SPK ORDER NO.
<p>OEHX 06 06 .. T</p> 	OEHX 060616 T 01020	SL 808	17.76.016.20.1
<p>ONHQ 06 06 .. T</p> 	ONHX 060616 T 01020	SL 808	17.76.017.20.1
<p>OPHN 05 04 .. T</p> 	OPHN 050412 T 01020	SL 500	36.72.001.20.0
<p>OPHX 06 06 .. T</p> 	OPHX 060616 T 01020	SL 808	17.76.014.20.1
<p>OPHX 06 06 08 T - 43Z150</p> 	OPHX 060608 T 01020 - 43Z150	SL 808	17.76.015.20.1

Ceramic inserts for milling



INSERT	TYPE	GRADE	SPK ORDER NO.
RPGN 06 03 T00520 	RPGN 06 03 00 T00520	LKM 840	23.42.334.03.2
RPGN 09 04 T00520 	RPGN 09 04 00 T00520	LKM 840	23.42.054.03.2
RNCX 12 07 .. T 01020 	RNCX 120700 T 01020	SL 808	17.40.196.20.1
		LKM 840	23.42.054.03.2
RNGN 12 04 00 T 	RNGN 120400 T 01020	LKM 840	23.40.027.20.2
	RNGN 120400 T 03015	SH 2	36.40.027.35.7
SDCN 12 04 .. T - 20 	SDCN 120408 T - 20	SL 500	36.12.340.20.0
		SL 808	17.12.340.20.1
	SDCN 120412 T - 20	SL 500	36.12.341.20.0
		SL 808	17.12.341.20.1
SDHW 09 T3 .. T 	SDHW 09T312 T 01020	SL 500	36.16.505.20.0

Ceramic inserts for milling

INSERT	TYPE	GRADE	SPK ORDER NO.									
<p>SECN 12 04 AF T</p>	SECN 1204 AF T 01020	SL 500	36.12.357.20.0									
<p>SEHW 12 04 AF T</p>	SEHW 1204 AF T 01020	SL 500	36.16.519.20.0									
<p>SNCN 09 04 04 T</p>	SNCN 090404 T 00520	SL 808	17.10.454.03.1									
<p>SNCN 09 04 ZN T</p>	<table border="1"> <tr> <td>SNCN 0904 ZN T 00520</td> <td>SL 500</td> <td>36.10.445.03.0</td> </tr> <tr> <td></td> <td>SL 808</td> <td>17.10.445.03.1</td> </tr> <tr> <td></td> <td>SL 854 C</td> <td>17.10.445.03.9</td> </tr> </table>	SNCN 0904 ZN T 00520	SL 500	36.10.445.03.0		SL 808	17.10.445.03.1		SL 854 C	17.10.445.03.9		
SNCN 0904 ZN T 00520	SL 500	36.10.445.03.0										
	SL 808	17.10.445.03.1										
	SL 854 C	17.10.445.03.9										
<p>SNCN 12 04 ZZ T</p>	SNCN 1204 ZZ T 00520	LKM 840	23.10.343.03.2									



INSERT	TYPE	GRADE	SPK ORDER NO.
SNCN 12 04 ZN T 	SNCN 1204 ZN T 00520	SL 500	36.10.409.03.0
		SL 808	17.10.409.03.1
		SL 854 C	17.10.409.03.9
		LKM 840	23.10.409.03.2
SNCN 12 04 ZN T - 88Z240 	SNCN 1204 ZN T 01020 - 88Z240	SL 500	36.10.493.20.0
		SL 808	17.10.493.20.1
SNFN 12 04 AN T 	SNFN 1204 AN T 03015	SH 2	36.10.223.35.7
SNGN 09 04 .. T 	SNGN 090408 T 01020	SL 808	17.10.049.20.1
	SNGN 090412 T 01020	SL 500	36.10.050.20.0
	SNGN 090412 T 03015	SH 2	36.10.050.35.7
SNGN 09 04 04 T - 88Z150 	SNGN 090404 T 01020 - 88Z150	SL 808	17.10.490.20.1

Ceramic inserts for milling

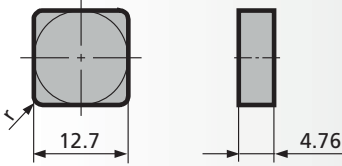
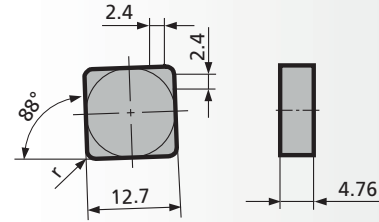
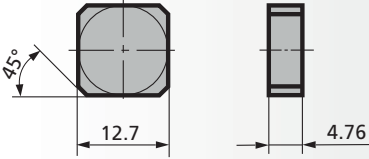
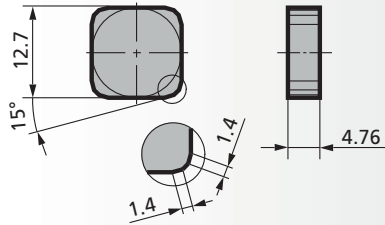
INSERT	TYPE	GRADE	SPK ORDER NO.
SNGN 12 04 .. T 	SNGN 120404 T 01020	SL 850 C	15.10.057.20.2
	SNGN 120408 T 01020	SL 500	36.10.009.20.0
		SL 808	17.10.009.20.1
		SL 850 C	15.10.009.20.2
		SL 854 C	17.10.009.20.9
	SNGN 120412 T01020	SL 500	36.10.058.20.0
		SL 808	17.10.058.20.1
		SL 850 C	15.10.058.20.2
		SL 854 C	17.10.058.20.9
		SL 858 C	21.10.058.20.1
	SNGN 120412 T 01020-CC	SL 808	17.10.473.20.1
SNGN 120412 T 03015	SH 2	36.10.058.35.7	
SNGN 12 04 08 T - 88Z240 	SNGN 120408 T 01020 - 88Z240	SL 500	36.10.503.20.0
		SL 808	17.10.503.20.1
SNGN 12 04 AN T 	SNGN 1204 AN T 01020	SL 500	36.10.232.20.0
		SL 808	17.10.232.20.1
SNGN 12 04 EN T 	SNGN 1204 EN T 01020	SL 500	36.10.261.20.0
		SL 808	17.10.261.20.0

Ceramic inserts for milling



INSERT	TYPE	GRADE	SPK ORDER NO.
SNHX 12 04 .. T 125 	SNHX 120412 T 125	SH 2	36.10.266.99.7
SOCN 12 04 .. T - 25 	SOCN 120416 T - 25 SL 500 SL 808	36.12.314.20.0 17.12.314.20.1	
SPCN 09 04 .. T 	SPCN 090408 T01020 SL 500 SL 506 SL 808 LKM 840	36.12.427.20.0 19.12.427.20.1 17.12.427.20.1 23.12.427.20.2	
SPCN 09 04 .. T - 88Z300 	SPCN 090408 T - 88Z300	SL 506	19.12.429.20.1
SPCN 12 04 .. T - 15 	SPCN 120416 T - 15 SL 500 SL 808	36.12.325.20.0 17.12.325.20.1	

Ceramic inserts for milling

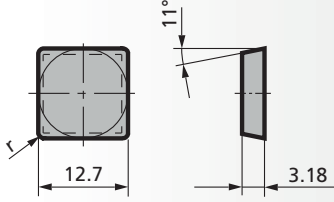
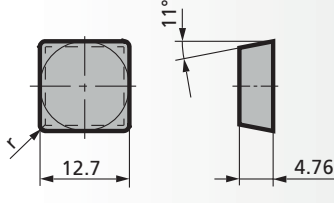
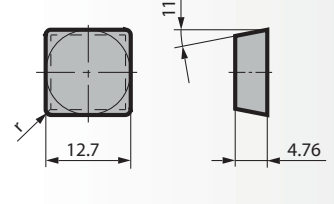
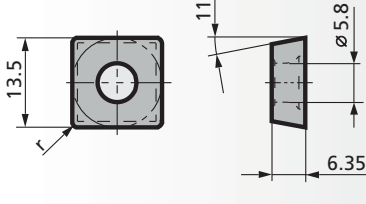
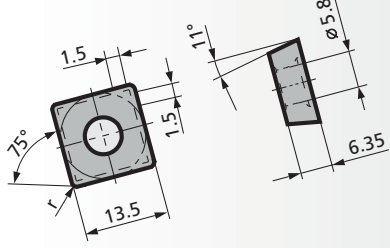
INSERT	TYPE	GRADE	SPK ORDER NO.
SPGN 12 03 .. T 	SPGN 120312 T 01020	SL 500	36.12.155.20.0
SPGN 12 04 .. T 	SPGN 120412 T 01020	SL 500 SL 808	36.12.163.20.0 17.12.163.20.1
SPHN 12 04 .. T 	SPHN 120416 T 01020	SL 500	36.12.869.20.0
SPHX 13 06 .. T 	SPHX 130612 T 01020	SL 808	17.16.535.20.1
SPHX 13 06 12 T - 75Z150 	SPHX 130612 T 01020 - 75Z150	SL 808	17.16.537.20.1

Ceramic inserts for milling



INSERT	TYPE	GRADE	SPK ORDER NO.
SPHX 13 06 12 T - 88Z150 	SPHX 130612 T 01020 - 88Z150	SL 808	17.16.536.20.1
SPKN 12 04 ED TR 	SPKN 1204 ED TR 01020	SL 500	36.12.246.20.0
TNCN 16 04 .. T 	TNCN 160404 T 01020	SL 808	17.30.190.20.1
		SL 854 C	17.30.190.20.9
	TNCN 160408 T 01020	SL 808	17.30.191.20.1
		SL 854 C	17.30.191.20.9
		SL 850 C	15.30.010.20.2
	TNCN 160412 T 01020	SL 808	17.30.192.20.1
	SL 854 C	17.30.192.20.9	
	SL 850 C	15.30.004.20.2	
TNCN 16 04 PC T 	TNCN 1604 PC T 01020	SL 808	17.30.209.20.1
TNCN 16 04 PN T 	TNCN 1604 PN T 01020	SL 808	17.30.189.20.1

Ceramic inserts for milling

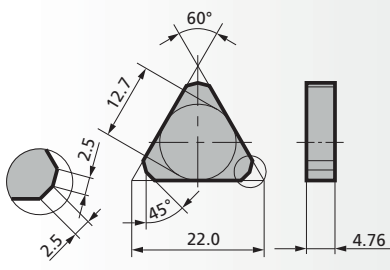
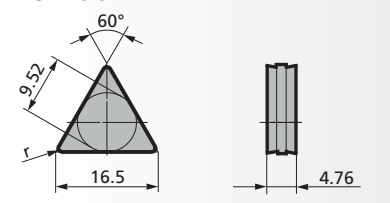
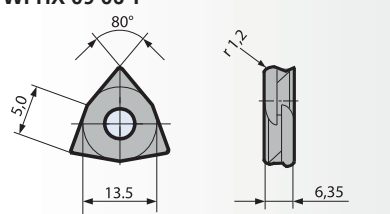
INSERT	TYPE	GRADE	SPK ORDER NO.
TNCN 22 04 AN T 	TNCN 2204 AN T 01020	SL 500	36.30.100.20.0
		SL 808	17.30.100.20.1
		SL 854 C	17.30.100.20.9
TNGN 16 04 T 	TNGN 160408 T 01020 - CC	SL 808	17.30.199.20.1
	TNGN 160412 T 01020 - CC	SL 808	17.30.198.20.1
WPHX 09 06 T 	WPHX 090612 T 00520	SL 808	17.66.035.03.1

Designation system for PcBN inserts, surface coated, for milling as per ISO 1832

V	35°	
D	55°	
E	75°	
C	80°	
M	86°	
K	55°	
B	82°	
A	85°	
R		
S	90°	
T	60°	
W	80°	
L		
P	108°	
H	120°	
O	135°	

Insert shape

N	0°
A	3°
B	5°
C	7°
P	11°
D	15°
E	20°
F	25°
G	30°
O	↓

Clearance angle, that requires particular specifications.

Clearance angle α_n

Inner circle											Inner circle	
d mm	RC, RN S	O 135°	H 120°	T 60°	C 80°	E 75°	D 55°	V 35°	W 80°	d mm	RB (Type MO)	
3.97				06						6.0	06	
5.56				09						7.0	07	
6.35				11	06		07			8.0	08	
9.52	09			16	09		11	16	06	9.0	09	
10.00							12			10.0	10	
12.70	12	05		22	12	13	15	22	08	12.0	12	
13.50	13	05										
15.88	15	06	09	27	16					16.0	16	
16.20			10									
16.50		06										
19.05	19			33						20.0	20	
25.40	25			44						25.0	25	

Insert size

S

N

C

N

12

04

Tolerances

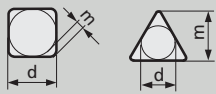

* Permissible deviation for insert shape, depending on the insert size

	S = ± mm	d = ± mm	m = ± mm	Inner circle	Tolerance class			
				d mm	J, K, L, M	U	M, N	U
					d = ± mm		m = ± mm	
A	0.025	0.025	0.005					
C	0.025	0.025	0.013					
E	0.025	0.025	0.025	3.97				
F	0.025	0.013	0.005	5.56	0.05	0.08	0.08	0.13
G	0.130	0.025	0.025	6.35				
H	0.025	0.013	0.013	9.52				
J	0.025	0.05-0.13*	0.005	12.70	0.08	0.13	0.13	0.2
K	0.025	0.05-0.13*	0.013	15.88				
L	0.025	0.05-0.13*	0.025	19.05	0.1	0.18	0.15	0.27
M	0.130	0.05-0.13*	0.08-0.18*	25.40				
U	0.130	0.08-0.25*	0.13-0.38*		0.13	0.25	0.18	0.38

Insert type

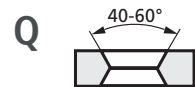
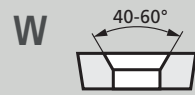

X Special design

Insert thickness

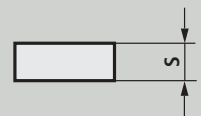

01	1.59
02	2.38
03	3.18
T3	3.97
04	4.76
05	5.56
06	6.35
07	7.94
09	9.52
12	12.70

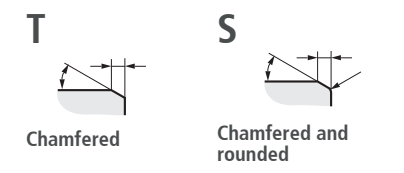
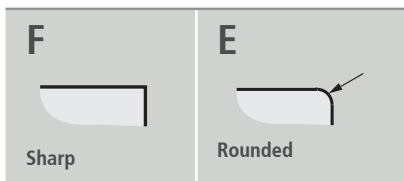

Cutting edge

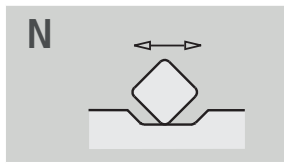
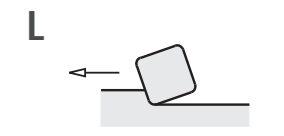
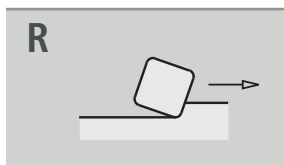

Cutting direction

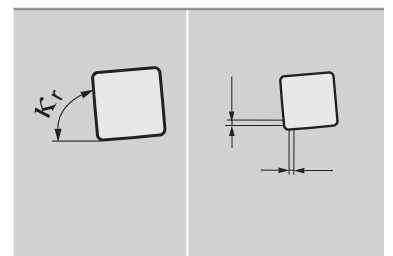

Cutting edge angle K_r	Width of the ZZ chamfer
43 = 43°	125 = 1.25 mm
47 = 47°	150 = 1.50 mm
75 = 75°	240 = 2.40 mm
88 = 88°	

Name key for ZZ-geometries

AN T N 01020 - F 88Z240

Corner radius

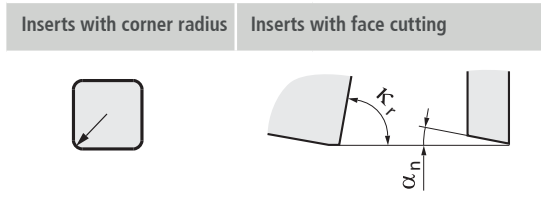

00	RN, RC	Cutting edge angle of the major cutting edge K_r		Clearance angle α_n	
M0	RB				
02	0.2				
04	0.4				
08	0.8	A	45°	N	0°
12	1.2	D	60°	C	7°
16	1.6	E	75°	P	11°
24	2.4	F	85°	D	15°
32	3.2	P	90°	E	20°
40	4.0	Z	other angles	F	25°

Chamfer design

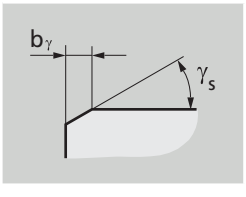

Chamfer width b_γ in 1/100 mm and angle γ_s without Degree symbol
 e.g.
 0.10 x 20° = 01020
 0.05 x 20° = 00520

CBN design

F	1-sided full surface coated
S	Solid CBN

Table of contents

PCBN inserts, full face laminated, for milling

RNCX



Page

113

RPCN



Page

113

PCBN inserts, full face laminated for milling

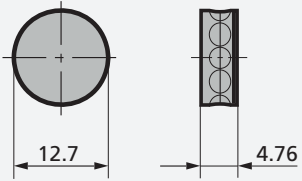
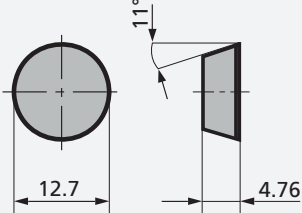

INSERT	TYPE	GRADE	SPK ORDER NO.
RNCX 12 04 .. S 	RNCX 120400 S01020	WXM 845	14.48.057.46.5
		WXM 848	14.48.057.46.9
RPCN 12 04 .. S 	RPCN 120400 S01020	WXM 845	14.48.060.46.1
		WXM 848	14.48.060.46.9

Designation system for PcBN inserts, solid, for milling as per ISO 1832

V	35°	
D	55°	
E	75°	
C	80°	
M	86°	
K	55°	
B	82°	
A	85°	
R		
S	90°	
T	60°	
W	80°	
L		
P	108°	
H	120°	
O	135°	

Insert shape

N	0°
A	3°
B	5°
C	7°
P	11°
D	15°
E	20°
F	25°
G	30°
O	↓

Clearance angle, which requires particular specifications.

Clearance angle α_n

Inner circle								Inner circle			
d mm	RC, RN S	O 135°	H 120°	T 60°	C 80°	E 75°	D 55°	V 35°	W 80°	d mm	RB (Type MO)
3.97				06						6.0	06
5.56				09						7.0	07
6.35				11	06		07			8.0	08
9.52	09			16	09		11	16	06	9.0	09
10.00							12			10.0	10
12.70	12	05		22	12	13	15	22	08	12.0	12
13.50	13	05									
15.88	15	06	09	27	16					16.0	16
16.20			10								
16.50		06									
19.05	19			33						20.0	20
25.40	25			44						25.0	25

Insert size

S

N

C

N

12

04

Tolerances

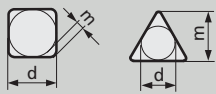

* Permissible deviation for insert shape, depending on the insert size

	S = ± mm	d = ± mm	m = ± mm	Inner circle	Tolerance class			
				d mm	J, K, L, M	U	M, N	U
					d = ± mm		m = ± mm	
A	0.025	0.025	0.005					
C	0.025	0.025	0.013					
E	0.025	0.025	0.025	3.97				
F	0.025	0.013	0.005	5.56	0.05	0.08	0.08	0.13
G	0.130	0.025	0.025	6.35				
H	0.025	0.013	0.013	9.52				
J	0.025	0.05-0.13*	0.005	12.70	0.08	0.13	0.13	0.2
K	0.025	0.05-0.13*	0.013	15.88				
L	0.025	0.05-0.13*	0.025	19.05	0.1	0.18	0.15	0.27
M	0.130	0.05-0.13*	0.08-0.18*	25.40				
U	0.130	0.08-0.25*	0.13-0.38*		0.13	0.25	0.18	0.38

Insert type

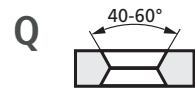
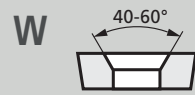

X Special design

Insert thickness

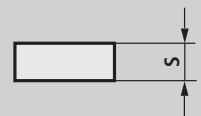

01	1.59
02	2.38
03	3.18
T3	3.97
04	4.76
05	5.56
06	6.35
07	7.94
09	9.52
12	12.70

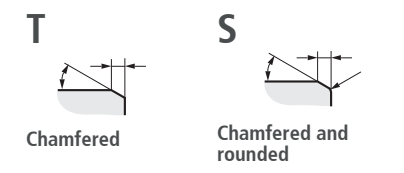
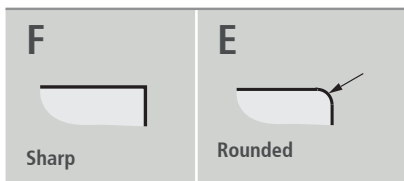

Cutting edge

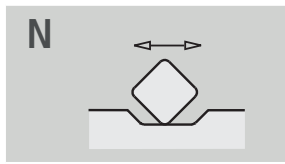
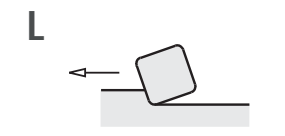
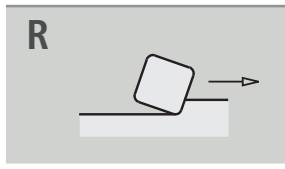

Cutting direction

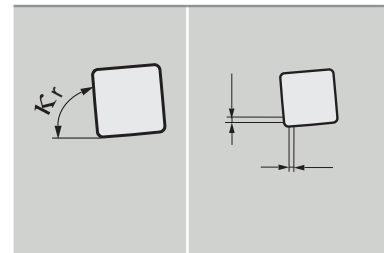

Cutting edge angle K_r	Width of the ZZ chamfer
43 = 43°	125 = 1.25 mm
47 = 47°	150 = 1.50 mm
75 = 75°	240 = 2.40 mm
88 = 88°	

Name key for ZZ-geometries

AN T N 01020 - S 88Z240

Corner radius

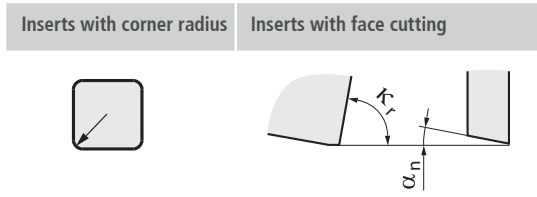

00	RN, RC				
M0	RB	Cutting edge angle of the major cutting edge K_r		Clearance angle α_n	
02	0.2				
04	0.4				
08	0.8	A	45°	N	0°
12	1.2	D	60°	C	7°
16	1.6	E	75°	P	11°
24	2.4	F	85°	D	15°
32	3.2	P	90°	E	20°
40	4.0	Z	other angles	F	25°

Chamfer design

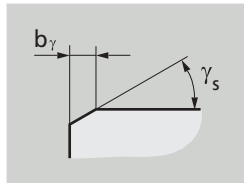

Chamfer width b_γ in 1/100 mm and angle γ_s without Degree symbol
 e.g.
 0.10 x 20° = 01020
 0.05 x 20° = 00520

CBN design

S	Solid CBN
---	-----------

Table of contents

PCBN inserts, solid, for milling

HNGN	
	
Page	117

SCHX, SPCN	
	
Page	117 - 118

SNGN, SNMN	
	
Page	117 - 118

TNGN	
	
Page	118

PCBN inserts, solid, for milling



INSERT	TYPE	GRADE	SPK ORDER NO.
HNGN 09 04 16 T - S 	HNGN 090416 T01020 - S 47Z125	WBN 101	20.62.011.20.1
SCHX 09 04 .. T 	SCHX 090408 T113 - S	WBN 101 WBN 115	20.18.001.99.1 12.19.001.99.0
SNGN 09 04 T - S 88Z150 	SNGN 090404 T - S 88Z150	WBN 115	12.12.093.20.0
SNGN 12 04 ZN T - S 88Z300 	SNGN 1204 ZN T01015 - S 88Z300	WBN 101	20.12.085.37.1
SNGN 09 04 T - S 88Z150 	SNGN 090404 T - S 88Z150	WBN 115	12.12.093.20.0
SNHX 12 04 T - S 	SNHX 120412 T125 - S	WBN 101 WBN 115	20.18.801.99.1 12.18.801.99.0

PCBN inserts, solid, for milling

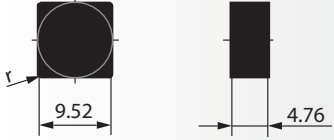
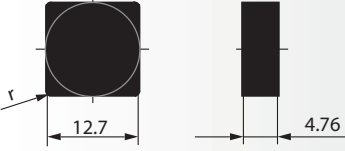
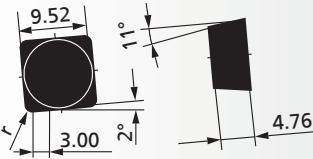
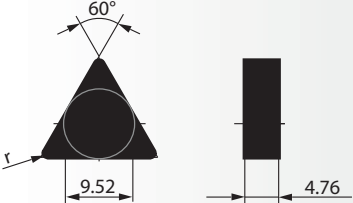
INSERT	TYPE	GRADE	SPK ORDER NO.
SNMN 09 04 08 T - S 	SNMN 090408 T00520 - S	WBN 101	20.10.021.03.1
SNMN 12 04 .. T - S 	SNMN 120408 T00520 - S	WBN 115	12.10.029.03.0
	SNMN 120412 T01020 - S	WBN 115	12.10.030.20.0
SPCN 09 04 .. T - S 88Z300 	SPCN 090408 T - S 88Z300	WBN 101	20.18.002.20.1
		WBN 115	12.18.002.20.0
TNGN 16 04 16 T00520 - S 	TNGN 160416 T00520 - S	WBN 101	20.30.016.03.1

Designation system for Cermet inserts for milling as per ISO 1832

V	35°
D	55°
E	75°
C	80°
M	86°
K	55°
B	82°
A	85°
R	
S	90°
T	60°
W	80°
L	
P	108°
H	120°
O	135°

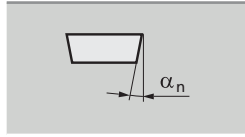

N	0°
A	3°
B	5°
C	7°
P	11°
D	15°
E	20°
F	25°
G	30°
O	↓

Clearance angle, which requires particular specifications.

Inner circle										Inner circle	
d mm	RC, RN S	O 135°	H 120°	T 60°	C 80°	E 75°	D 55°	V 35°	W 80°	d mm	RB (Type MO)
3.97				06						6.0	06
5.56				09						7.0	07
6.35				11	06		07			8.0	08
9.52	09			16	09		11	16	06	9.0	09
10.00							12			10.0	10
12.70	12	05		22	12	13	15	22	08	12.0	12
13.50	13	05									
15.88	15	06	09	27	16					16.0	16
16.20			10								
16.50		06									
19.05	19			33						20.0	20
25.40	25			44						25.0	25

Insert shape

Clearance angle α_n

Insert size

S

N

C

N

12

Tolerances

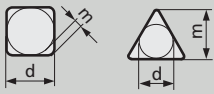

* Permissible deviation for insert shape, depending on the insert size

	S = ± mm	d = ± mm	m = ± mm	Inner circle	Tolerance class			
				d mm	J, K, L, M	U	M, N	U
					d = ± mm		m = ± mm	
A	0.025	0.025	0.005					
C	0.025	0.025	0.013					
E	0.025	0.025	0.025					
F	0.025	0.013	0.005	3.97				
G	0.130	0.025	0.025	5.56	0.05	0.08	0.08	0.13
H	0.025	0.013	0.013	6.35				
J	0.025	0.05-0.13*	0.005	9.52				
K	0.025	0.05-0.13*	0.013	12.70	0.08	0.13	0.13	0.2
L	0.025	0.05-0.13*	0.025	15.88				
M	0.130	0.05-0.13*	0.08-0.18*	19.05	0.1	0.18	0.15	0.27
U	0.130	0.08-0.25*	0.13-0.38*	25.40	0.13	0.25	0.18	0.38

Insert type

N		T	
R		Q	
F		U	
A		B	
M		H	
G		C	
W		J	

X Special design



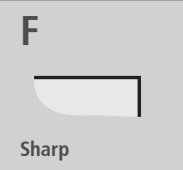

F
Sharp

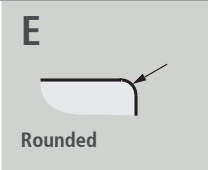

E
Rounded

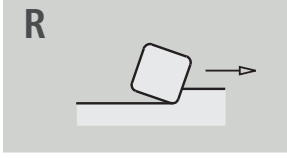

R

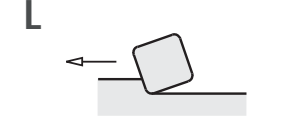

L

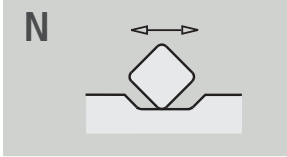

N

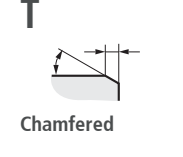

T
Chamfered

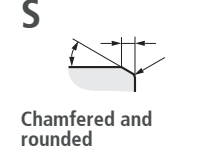

S
Chamfered and rounded

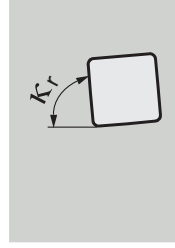

Cutting edge angle K_r

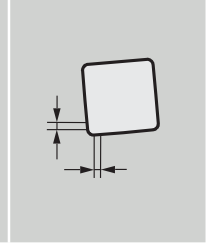

Width of the ZZ chamfer

75 = 75°	125 = 1.25 mm
88 = 88°	150 = 1.50 mm
89 = 89°	240 = 2.40 mm

Cutting edge

Cutting direction

Name key for ZZ-geometries

04 ZN F N 01020 - 89Z240

Insert thickness

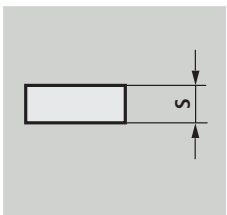

01	1.59
02	2.38
03	3.18
T3	3.97
04	4.76
05	5.56
06	6.35
07	7.94
09	9.52
12	12.70

Corner radius / face cutting

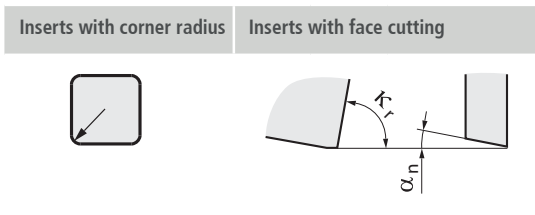

Inserts with corner radius		Inserts with face cutting			
00	RN, RC			Cutting edge angle of the major cutting edge K_r	Clearance angle α_n
M0	RB				
02	0.2				
04	0.4				
08	0.8	A	45°	N	0°
12	1.2	D	60°	C	7°
16	1.6	E	75°	P	11°
24	2.4	F	85°	D	15°
32	3.2	P	90°	E	20°
40	4.0	Z	Special	F	25°

Chamfer design

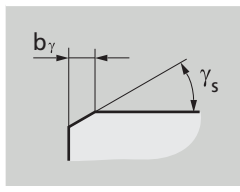

Chamfer width b_γ in 1/100 mm and angle γ_s without Degree symbol

e.g.
 0.10 x 20° = 01020
 0.05 x 20° = 00520

Table of contents

Cermet inserts for milling

SCHX, SDCN, SEKN, SPCN,
SPKN



Page 123 - 125

SNCN, SNGN, SNGX



Page 123 - 124

SPEW, SPGB



Page 125

Cermet inserts for milling



INSERT	TYPE	GRADE	SPK ORDER NO.
SCHX 09 04 .. T 	SCHX 090408 T113	TS 5115	50.19.001.99
SDCN 120408 E - 20 	SDCN 120408 E - 20	SC 7015	46.15.104.41.9
SEKN 1203 AF TN 	SEKN 1203 AF TN	SC 60	46.15.035.40.6
		SC 7015	46.15.035.40.9
SEKN 1204 AF TN 	SEKN 1204 AF TN	SC 60	46.15.068.01.6
		SC 7015	46.15.068.01.9
SNCN 1204 ZN F - 89Z240 	SNCN 1204 ZN F - 89Z240	SC 7015	46.10.042.01.9

Cermet inserts for milling

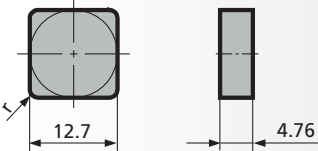
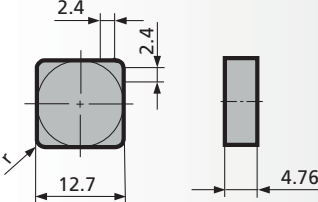
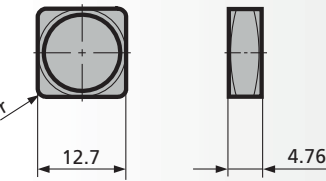
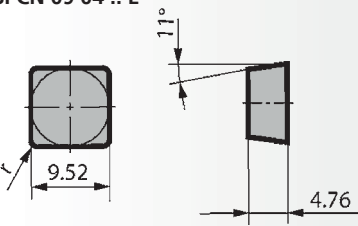
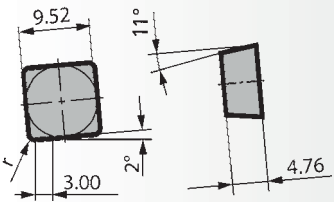
INSERT	TYPE	GRADE	SPK ORDER NO.
SNGN 1204 .. T 	SNGN 120412 T	SC 60	46.10.001.40.6
		SC 7015	46.10.001.40.9
SNGN 1204 12 F - 89Z240 	SNGN 120412 F - 89Z240	SC 60	46.10.037.01.6
		SC 7015	46.10.037.01.9
SNGX 1204 .. T124 	SNGX 120412 T124	SC 7015	46.10.016.99.9
SPCN 09 04 .. E 	SPCN 090408 E	TS 5115	50.19.000.40.8
SPCN 09 04 .. E - 88Z300 	SPCN 090408 E - 88Z300	TS 5115	50.19.002.40.8

Cermet inserts for milling



INSERT	TYPE	GRADE	SPK ORDER NO.
SPEW 1204 .. T 	SPEW 120408 T	SC 60	46.15.037.40.6
		SC 7015	46.15.037.40.9
SPEW 1204 ED TR 	SPEW 1204 ED TR	SC 60	46.15.040.40.6
		SC 7015	46.15.040.40.9
SPGB 0903 .. T 123 	SPGB 090308 T123	SC 60	46.17.013.40.6
		SC 7015	46.17.013.40.9
SPKN 1203 ED TR 	SPKN 1203 ED TR	SC 60	46.15.010.40.6
		SC 7015	46.15.010.40.9
SPKN 1204 ED TR 	SPKN 1204 ED TR	SC 60	46.15.065.40.6
		SC 7015	46.15.065.40.9

Recommended cutting data:



Recommended cutting data for cast iron with lamellar graphite – GJL

CAST IRON WITH LAMELLAR GRAPHITE

Operating reference values for rough milling, $a_p \leq 4.0$ mm, surface qualities $R_a = 6.3 - 12.5 \mu\text{m}$

GJL (GG)	Recommended value v_c	Overall range v_c	Recommended value f_t	Overall range f_t			Cutting material
Hardness (HB)	m/min	m/min	mm/z	43°/45°	75°	88°/90°	
190-210	800	600-2000	0.18	0.12-0.30	0.12-0.20	0.12-0.22	SL 500
	1000	800-2000	0.20	0.14-0.30	0.14-0.20	0.14-0.25	SL 808
	1500	800-2000	0.20	0.10-0.22	0.10-0.18	0.10-0.20	WBN 101
	1500	800-2000	0.18	0.10-0.25	0.10-0.18	0.10-0.22	WBN 115
220-240	800	500-1300	0.18	0.12-0.30	0.12-0.20	0.12-0.22	SL 500
	1000	500-1500	0.20	0.14-0.30	0.14-0.20	0.14-0.25	SL 808
	1200	500-1500	0.20	0.10-0.22	0.10-0.18	0.10-0.20	WBN 101
	1200	500-1500	0.18	0.10-0.25	0.10-0.18	0.10-0.22	WBN 115
250-280	700	400-1200	0.18	0.12-0.30	0.12-0.20	0.12-0.22	SL 500
	800	300-1200	0.20	0.14-0.30	0.14-0.20	0.14-0.25	SL 808
	900	300-1200	0.20	0.10-0.22	0.10-0.18	0.10-0.20	WBN 101
	900	300-1200	0.18	0.10-0.25	0.10-0.18	0.10-0.22	WBN 115

Operating reference values for finishing, $a_p = 0.5 - 1.0$ mm, surface qualities $R_a = 3.2 \mu\text{m}$

GJL (GG)	Recommended value v_c	Overall range v_c	Recommended value f_t	Overall range f_t			Cutting material
Hardness (HB)	m/min	m/min	mm/z	43°/45°	75°	88°/90°	
190-210	700	200-900	0.10	0.08-0.20	0.08-0.15	0.08-0.15	SH 2
	1300	800-1500	0.12	0.12-0.20	0.12-0.18	0.12-0.20	SL 850C
	1300	800-1500	0.12	0.12-0.20	0.12-0.18	0.12-0.20	SL 854C
	1500	800-2000	0.16	0.10-0.20	0.10-0.15	0.12-0.22	SL 858C
	1500	800-2000	0.14	0.10-0.20	0.10-0.15	0.08-0.15	WBN 101
220-240	1500	800-2000	0.14	0.10-0.20	0.10-0.15	0.10-0.20	WBN 115
	500	200-700	0.10	0.08-0.20	0.08-0.15	0.08-0.15	SH 2
	900	500-1300	0.12	0.12-0.20	0.12-0.18	0.12-0.20	SL 850C
	900	500-1300	0.12	0.12-0.20	0.12-0.18	0.12-0.20	SL 854C
	1000	500-1500	0.16	0.10-0.20	0.10-0.15	0.12-0.22	SL 858C
250-280	1200	500-1500	0.14	0.10-0.20	0.10-0.15	0.08-0.15	WBN 101
	1200	500-1500	0.14	0.10-0.20	0.10-0.15	0.10-0.20	WBN 115
	400	200-500	0.10	0.08-0.20	0.08-0.15	0.08-0.15	SH 2
	800	300-1000	0.12	0.12-0.20	0.12-0.18	0.12-0.20	SL 850C
	800	300-1000	0.12	0.12-0.20	0.12-0.18	0.12-0.20	SL 854C
	800	300-1200	0.16	0.10-0.20	0.10-0.15	0.12-0.22	SL 858C

Recommended cutting data for cast iron with lamellar graphite – GJL

Operating reference values for fine finishing, $a_p = 0.1 - 0.5$ mm, surface qualities $R_a = 0.5$ μm

GJL (GG)	Recommended value v_c	Overall range v_c	Recommended value f_t	Overall range f_t			Cutting material
Hardness (HB)	m/min	m/min	mm/z	43°/45°	75°	88°/90°	
190-210	1200	800-2000	0.12	0.10-0.20	0.10-0.15	0.08-0.15	WBN 101
	1200	800-2000	0.12	0.10-0.20	0.10-0.15	0.08-0.15	WBN 115
220-240	1000	500-1500	0.12	0.10-0.20	0.10-0.15	0.08-0.15	WBN 101
	1000	500-1500	0.12	0.10-0.20	0.10-0.15	0.08-0.15	WBN 115

Recommended cutting data for cast iron with spheroidal graphite – GJS

CAST IRON WITH SPHEROIDAL GRAPHITE

Operating reference values for rough milling, $a_p \leq 5.0$ mm, surface qualities $Ra = 6.3 - 12.5 \mu\text{m}$

GJS (GGG)	Recommended value v_c	Overall range v_c	Recommended value f_t	Overall range f_t			Cutting material
Tensile strength RM (N/mm ²)	m/min	m/min	mm/z	43°/45°	75°	88°/90°	
400-500	800	600-1000	0.18	0.15-0.30	0.12-0.20	0.14-0.21	SL 808
500-700	700	500-800	0.18	0.15-0.30	0.12-0.20	0.14-0.21	SL 808

Operating reference values for rough finishing, $a_p \leq 0.5 - 1.0$ mm, surface qualities $Ra = 6.3 \mu\text{m}$

GJS (GGG)	Recommended value v_c	Overall range v_c	Recommended value f_t	Overall range f_t			Cutting material
Tensile strength RM (N/mm ²)	m/min	m/min	mm/z	43°/45°	75°	88°/90°	
400-500	800	600-1000	0.16	0.15-0.30	0.12-0.25	0.12-0.20	SL 850C
	800	600-1000	0.16	0.15-0.30	0.12-0.25	0.12-0.20	SL 854C
500-700	800	600-100	0.16	0.15-0.30	0.12-0.25	0.12-0.20	SL 858C
	700	500-800	0.16	0.15-0.30	0.12-0.25	0.12-0.20	SL 850C
	700	500-800	0.16	0.15-0.30	0.12-0.25	0.12-0.20	SL 854C
	700	500-800	0.16	0.15-0.30	0.12-0.25	0.12-0.20	SL 858C

Operating reference values for finish milling, $a_p \leq 0.5 - 1.0$ mm, surface qualities $Ra = 3.2 \mu\text{m}$

GJS (GGG)	Recommended value v_c	Overall range v_c	Recommended value f_t	Overall range f_t			Cutting material
Tensile strength RM (N/mm ²)	m/min	m/min	mm/z	43°/45°	75°	88°/90°	
400-500	500	350-600	0.12	0.10-0.20	0.10-0.15	0.08-0.15	SC 7015
500-700	400	250-500	0.12	0.10-0.20	0.10-0.15	0.08-0.15	SC 7015

Operating reference values for finish milling, $a_p \leq 1.0$ mm, surface qualities $Ra = 0.8 - 1.6 \mu\text{m}$

GJS (GGG)	Recommended value v_c	Overall range v_c	Recommended value f_t	Overall range f_t			Cutting material
Tensile strength RM (N/mm ²)	m/min	m/min	mm/z	43°/45°	75°	88°/90°	
400-500	500	350-600	0.12	0.10-0.20	0.10-0.15	0.08-0.15	SC 60
500-700	400	250-500	0.12	0.10-0.20	0.10-0.20	0.08-0.15	SC 60

Operating reference values for fine milling, $a_p \leq 0.1 - 0.5$ mm, surface qualities $Ra = 0.8 \mu\text{m}$

GJS (GGG)	Recommended value v_c	Overall range v_c	Recommended value f_t	Overall range f_t			Cutting material
Tensile strength RM (N/mm ²)	m/min	m/min	mm/z	43°/45°	75°	88°/90°	
400-500	500	350-600	0.10	0.08-0.20	0.08-0.15	0.08-0.15	SC 60
500-700	400	250-500	0.10	0.08-0.20	0.08-0.15	0.08-0.15	SC 60



CAST IRON WITH VERMICULAR GRAPHITE

Operating reference values for rough milling, $a_p \leq 5.0$ mm, surface qualities $Ra = 6.3 - 12.5 \mu\text{m}$

GJV (GGV)	Recommended value v_c	Overall range v_c	Recommended value f_t	Overall range f_t			Cutting material
				43°/45°	75°	88°/90°	
Tensile strength RM (N/mm ²)	m/min	m/min	mm/z	43°/45°	75°	88°/90°	
300	800	500-1000	0.20	0.15-0.22	0.12-0.22	0.12-0.22	SL 850C
	800	500-1000	0.18	0.12-0.22	0.12-0.22	0.12-0.22	SL 854C
	800	500-1000	0.2	0.12-0.22	0.12-0.22	0.12-0.22	SL 858C
350-400	600	400-800	0.18	0.12-0.20	0.12-0.20	0.12-0.20	SL 850C
	600	400-800	0.16	0.12-0.20	0.12-0.20	0.12-0.18	SL 854C
	600	400-800	0.18	0.12-0.20	0.12-0.20	0.12-0.20	SL 858C
450-500	400	200-600	0.16	0.12-0.16	0.12-0.20	0.12-0.20	SL 850C
	400	200-600	0.14	0.12-0.16	0.10-0.20	0.12-0.18	SL 854C
	400	200-600	0.16	0.12-0.16	0.12-0.20	0.12-0.20	SL 858C

Recommended cutting data for high silicon content Cast iron with spheroidal graphite, chilled cast iron

HIGH-SILICON CAST IRON WITH SPHEROIDAL GRAPHITE

Operating reference values for rough machining, $a_p \leq 5.0$ mm, surface qualities $R_a = 6.3 - 12.5 \mu\text{m}$

GJS (high silicon content)	Recommended value v_c	Overall range v_c	Recommended value f_t	Overall range f_t			Cutting material
				43°/45°	75°	88°/90°	
Tensile strength RM (N/mm ²)	m/min	m/min	mm/z	43°/45°	75°	88°/90°	
450	1500	800-1100	0.18	0.10-0.22	0.10-0.22	0.12-0.22	SL 850C
	1500	800-2000	0.16	0.10-0.20	0.10-0.16	0.12-0.22	SL 854C
	1500	800-2000	0.16	0.10-0.20	0.10-0.15	0.12-0.22	SL 858C
500	1500	800-1000	0.16	0.10-0.20	0.10-0.20	0.12-0.22	SL 850C
	1500	800-2000	0.16	0.10-0.20	0.10-0.16	0.12-0.22	SL 854C
	1500	800-2000	0.16	0.10-0.20	0.10-0.15	0.12-0.22	SL 858C
600	1200	800-900	0.16	0.10-0.20	0.10-0.20	0.12-0.22	SL 850C
	1200	800-2000	0.16	0.10-0.20	0.10-0.16	0.12-0.22	SL 854C
	1200	800-2000	0.16	0.10-0.20	0.10-0.15	0.12-0.22	SL 858C

CHILLED CAST IRON

Operating reference values for finish milling, $a_p = 0.1 - 0.5$ mm, surface qualities $R_a = 1.6 - 3.2 \mu\text{m}$

GJN (chilled cast iron)	Recommended value v_c	Overall range v_c	Recommended value f_t	Overall range f_t	Cutting material
35-40	300	100-450	0.10	0.05-0.15	SH 2
40-45	300	100-450	0.10	0.05-0.15	SH 2
45-50	250	80-400	0.10	0.05-0.15	SH 2
hardened HRC					
55-63	250	80-400	0.10	0.05-0.15	SH 2
58-64	200	80-350	0.10	0.05-0.15	SH 2
60-65	180	80-300	0.10	0.05-0.15	SH 2

Operating reference values for fine milling, $a_p = 0.1 - 0.5$ mm, surface qualities $R_a = 0.8 - 3.2 \mu\text{m}$

Hardened cast iron	Recommended value v_c	Overall range v_c	Recommended value f_t	Overall range f_t	Cutting material
68	250	80-400	0.10	0.05-0.15	WBN 115
73	250	80-400	0.10	0.05-0.15	WBN 115
80	220	80-300	0.10	0.05-0.15	WBN 115
87	200	80-300	0.10	0.05-0.15	WBN 115
93	180	80-250	0.10	0.05-0.15	WBN 115

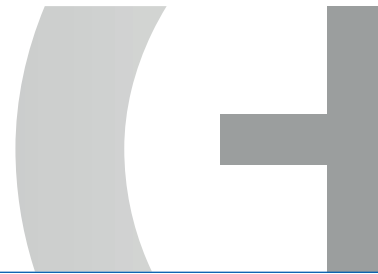

CONSTRUCTION- AND FREE-CUTTING STEEL

Operating reference values for finish milling, $a_p = 0.5 - 1.0$ mm, surface qualities $R_a = 3.2 \mu\text{m}$

Tensile strength	Recommended value v_c	Overall range v_c	Recommended value f_t	Overall range f_t			Cutting material
RM (N/mm ²)	m/min	m/min	mm/z	43°/45°	75°	88°/90°	
	400	250-400	0.12	0.10-0.20	0.10-0.15	0.08-0.15	SC 7015
	300	200-350	0.12	0.10-0.20	0.10-0.15	0.08-0.15	SC 7015

Operating reference values for fine milling, $a_p = 0.1 - 0.5$ mm, surface qualities $R_a = 0.8 \mu\text{m}$

Tensile strength	Recommended value v_c	Overall range v_c	Recommended value f_t	Overall range f_t			Cutting material
RM (N/mm ²)	m/min	m/min	mm/z	43°/45°	75°	88°/90°	
300-500	400	250-450	0.10	0.08-0.15	0.05-0.12	0.05-0.12	SC 7015
550-700	300	200-350	0.10	0.08-0.15	0.05-0.12	0.05-0.12	SC 7015

Recommended cutting data for case hardening and tempering steel

CASE-HARDENING AND TEMPERED STEEL

Operating reference values for rough machining and rough finishing, $a_p \leq 5.0$ mm, surface qualities $R_a = 6.3 - 12.5 \mu\text{m}$

Tensile strength	Recommended value v_c	Overall range v_c	Recommended value f_t	Overall range f_t			Cutting material
RM (N/mm ²)	m/min	m/min	mm/z	43°/45°	75°	88°/90°	
600-900	250	100-350	0.20	0.15-0.30	0.10-0.25	0.08-0.20	SC 60
900-1300	200	100-250	0.20	0.15-0.30	0.10-0.25	0.08-0.20	SC 60

Operating reference values for finish milling, $a_p = 0.5 - 1.0$ mm, surface qualities $R_a = 3.2 \mu\text{m}$

Tensile strength	Recommended value v_c	Overall range v_c	Recommended value f_t	Overall range f_t			Cutting material
RM (N/mm ²)	m/min	m/min	mm/z	43°/45°	75°	88°/90°	
600-900	350	250-400	0.12	0.10-0.20	0.10-0.15	0.05-0.12	SC 7015
900-1300	250	200-350	0.12	0.10-0.20	0.10-0.15	0.05-0.12	SC 7015

Operating reference values for fine milling, $a_p = 0.10 - 0.50$ mm, surface qualities $R_a = 0.8 \mu\text{m}$

Tensile strength	Recommended value v_c	Overall range v_c	Recommended value f_t	Overall range f_t			Cutting material
RM (N/mm ²)	m/min	m/min	mm/z	43°/45°	75°	88°/90°	
600-900	250	250-400	0.10	0.08-0.15	0.05-0.12	0.05-0.12	SC 7015
900-1300	250	200-350	0.10	0.08-0.15	0.05-0.12	0.05-0.12	SC 7015

Recommended cutting data for steel, hardened

HARDENED STEEL

Operating reference values for finish milling, $a_p = 0.10 - 1.0$ mm, surface qualities $R_a = 0.8 - 3.2$ μm

Hardness	Recommended value v_c	Overall range v_c	Recommended value f_t	Overall range f_t	Cutting material
HRC	m/min	m/min	mm/z		
48	120	100-150	0.12	0.05-0.20	WXM 845
52	120	100-150	0.12	0.05-0.20	WXM 845
56	100	80-130	0.10	0.05-0.20	WXM 845
60	90	80-130	0.10	0.05-0.20	WXM 845
64	90	80-130	0.10	0.05-0.20	WXM 845

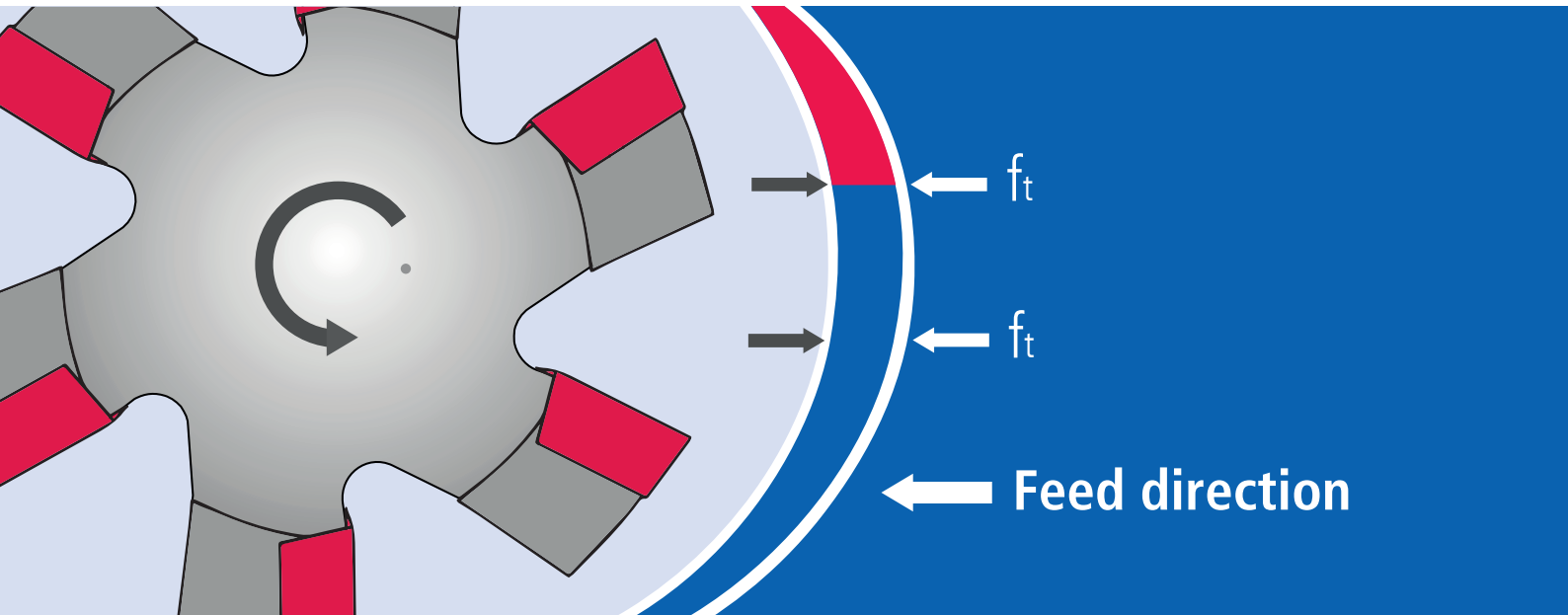

BASICS OF MILLING

In order to become more familiar with the subject of milling, an understanding of the cutting path that forms during milling is very helpful. This can help explain many problems quickly and easily. As you know, the tool rotates during milling. Due to the rotation of the milling cutter, the cutting edge follows a circular path.

The workpiece itself performs a longitudinal movement (feed motion). During face milling, it moves perpendicular to the axis of rotation of the milling cutter. This creates a superposed movement (cycloidal movement) at the cutting point. The following image shows the chip cross-section during milling, which results from the superposition of the movement.

CLIMB MILLING / CONVENTIONAL MILLING

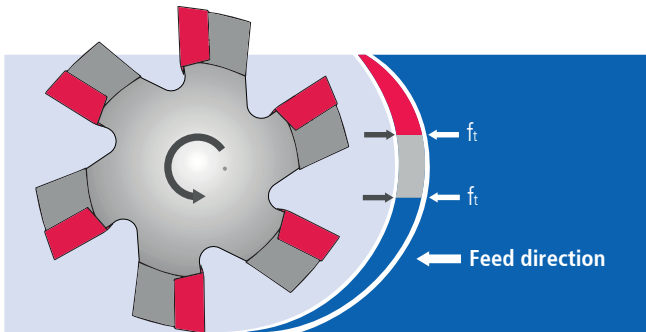

Course of the chip section through the material removed by a tooth

As shown by the three colors of the chip, three areas can be distinguished during chip formation.

Blue area: Area of cutting in. The chip initially forms very thin. Since there is a lot of friction at first, there is a risk of chips welding together and heat being transferred to the insert and workpiece. In this entry zone, material hardening can occur, which becomes smaller the larger the chip cross section becomes.

Gray area: Here, the chip cross section corresponds to the feed per tooth. The main forces act against the feed direction.

Red area: In the exit area, the chip cross section decreases rapidly and possible heat input is minimized. However, the cutting forces perpendicular to the feed direction, towards the residual material, increase rapidly.

The chip formation was described here on the principle of conventional milling.

A desirable alternative to conventional milling is climb milling. The chip cross section that forms is the same as in the case of conventional milling. However, the red area is the cut in zone and the blue area is the cut out zone.

Red area: The hammering stress of the insert and the workpiece material is high here. With the optimum cutter position and cutter size, the insert hits the workpiece with full f_t width and a_p depth.

Blue area: When cutting out, the chip cross-section tapers. Heat input into the insert and the workpiece as well as material hardening is minimized.

The forces involved in climb milling direct the resulting force in the feed direction and push the workpiece into the jig. In conventional milling, the resulting cutting force tends to lift the workpiece out of the jig.

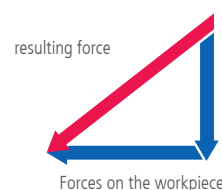
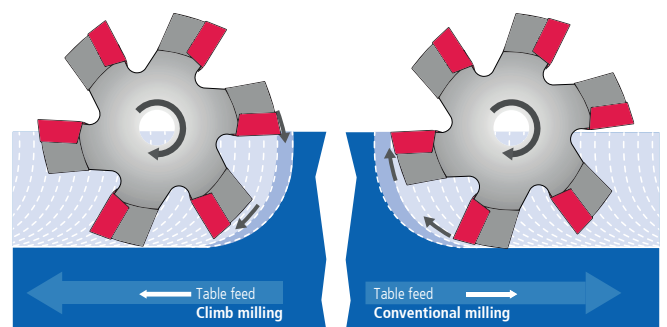

MILLING CUTTER POSITION AND SIZE

The blue area in the following image shows which part of the chip cross-section is to be aimed at in the optimum case during milling. This shows that cutting in and cutting out are important factors in milling.

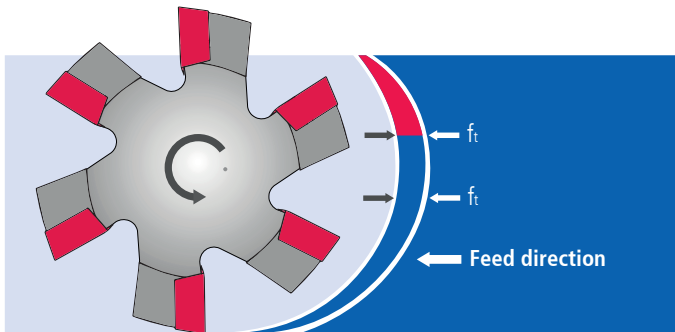

Course of the chip section through the material removed by a tooth

For example, when milling, it is important to hit the blue desired area. The correcting variables for this are the milling cutter position and the milling cutter diameter. The optimum milling cutter diameter for face milling depends on the milling width. Two basic cases are to be distinguished here:

Case 1:

Narrow milling paths that can be machined with one cut. The basic rule here is that the milling cutter should be 1.5 times larger in diameter than the milling path width. For example, if the milling path width is 80 mm, the milling cutter diameter should be about 120 mm.

Case 2:

Wide milling paths that can be machined with one cut. Here, the milling machine, the clamping situation, and the component stability must be taken into account.

- a) Machine rigidity, spindle power and cutter receptacle: A cutter width that corresponds to the spindle power and the rigidity of the receptacle must be selected.
- b) Clamping situation: Pay attention to the main direction of the cutting forces.
- c) Thin-walled and unstable components: Ensure component stability.

Basically, about 2/3 of the milling cutter should be in contact. If a milling cutter has a diameter of 250 mm, this results mathematically in a desired contact width of 166 mm. Depending on the machine situation, the milling path width (milling cutter wrap) can be increased. As a rule of thumb, a wrap of more than 80% is not recommended. If the optimal milling cutter diameter is not available, then about 25% of the cutter should not be in contact. The number of milling paths should then be selected accordingly.

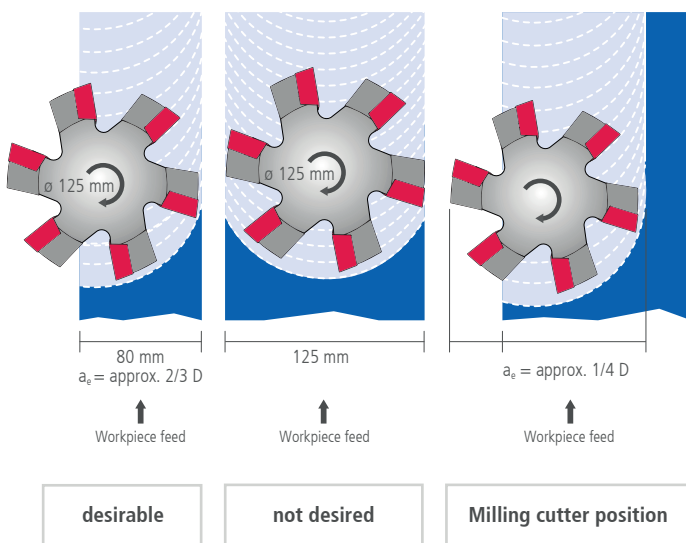



Basically, the milling cutter position should always be slightly out of center, as here the cut length of each insert is the shortest. As you can also see from the left image, the entry and exit of the cut leads to good chip formation with moderate impact load.

When centered, the radial forces are the same when cutting in and out. Since input and output do not occur at the same time, vibrations occur. These vibrations can damage the spindle of the milling machine, the wear of the indexable insert increases and the surface quality deteriorates (image left, middle).

Application technology

If a cutting edge strikes the material to be machined, it is exposed to a large load, which results from the material, the type of cutting and the chip cross section. The following table shows that, depending on the wrap, favorable or unfavorable entry and exit conditions may arise. The main influencing variables can be shown based on three cases.

Location of the milling cutter center	Impact loading	Chip thickness	Insert loading
	moderate	moderate	Very high. The impact load is received by the insert tip during entry and exit.
	very high	corresponds to f_t	The insert loading is highest, but the rake face of the insert is loaded according to the chip thickness h . This relieves the delicate tip, as the rake face is loaded by the tip by the same amount as f_t during entry and exit.
	moderate	moderate	Softer cutting in. The insert will be loaded further back. The problem is that burrs can form on the edge of the workpiece and the cutting insert is then subjected to a higher load when it exits.

EXIT ANGLE OF THE INSERT

The angle at which an insert leaves the workpiece influences the burr formation. The remaining material can yield at a positive exit angle. In the further course, the residual material is pulled along the end face of the cutting edge (partially plastically deformed). Part of the deformed residual material then remains as burr on the edge of the workpiece.

In this process, tensile forces also occur at the end face of the cutting edge, which subjects them to additional loads. The insert should leave the workpiece at a negative angle to the cutting edge. The remaining residual material can then be machined better.

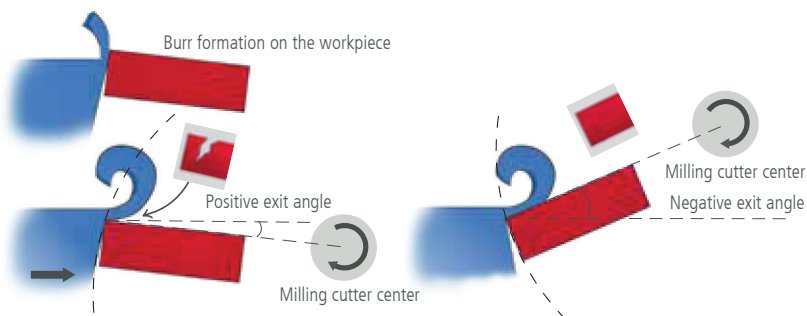

MILLING CUTTER PITCH

	Wide pitch	Normal pitch	Narrow pitch
Cutting forces	low	moderate	high
Machine output	low	moderate	high
Feed per tooth	high	moderate	low
Table feed	moderate	moderate	high
Milling forces	high	moderate	low
Number of cut interruptions in the milling path	few	moderate	many

Wide pitch is suitable for general milling operations at rather low machine power.

Normal pitch – Since more inserts are in contact here, the impact forces during cutting are reduced. The required spindle power increases, however, as the radial cutting forces increase.

Narrow pitch is particularly suitable for many cutting interruptions on the milling path and at high table feeds and moderate cutting depths with sufficient spindle power. It is to be preferred for thin-walled, labile components.

NUMBER OF INSERTS IN CONTACT

The number of inserts simultaneously in contact in the workpiece depends on the number of inserts of the milling cutter and the milling cutter wrap angle α . The angle α depends on the contact width a_e and the effective diameter D_c of the milling cutter.

This can be calculated with: $z_c = z \times \alpha / 360^\circ$

Furthermore, the same effects as described above result when milling with milling shanks with narrow pitch, normal pitch, and wide pitch.

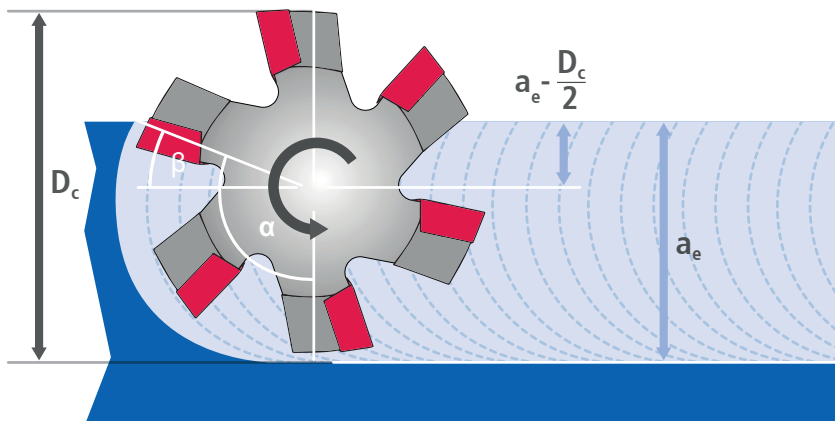

- α = pressure angle
- β = angle between milling cutter center line and milling cutter radius to the peripheral point of exit or entry
- a_e = contact width
- D_c = effective diameter of the milling cutter

Scheme for calculating the number of inserts in the section

CUTTING EDGE ANGLE, CUTTING FORCES AND CHIP THICKNESS

The distribution of forces in the axial and radial direction results from the cutting edge angle of the insert. The cutting edge angle of the insert also defines the chip thickness h . The chip thickness h , in turn, results from the cutting edge angle K_r of the insert and contact on the workpiece surface.

The chip thickness decreases as the cutting edge angle decreases. A smaller cutting edge angle results in a greater length of the cutting edge in contact. As the pressure angle decreases, the direction of force changes from radial, acting counter to the feed direction (lower left image), to high axial forces acting in the spindle direction (lower right image).

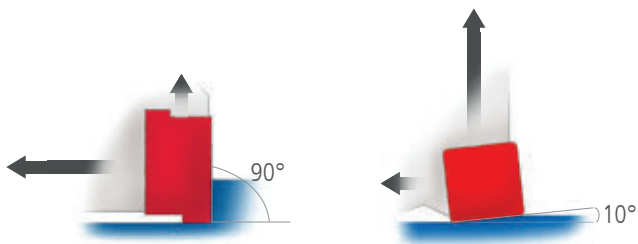

Connection between cutting edge angle and force distribution:

Cutting edge angle	Advantages	Effects	Force distribution
90°	<ul style="list-style-type: none"> For 90° shoulders Suitable for thin-walled components, as the main force acts counter to the feed direction 	<ul style="list-style-type: none"> Maximum radial cutting forces Very high impact load of the cutting edge when cutting in Burr formation during cut out is probable 	
75°	<ul style="list-style-type: none"> For rough machining Reduced cutting edge load when cutting in Better ratio of radial and axial forces Optimal cutting depth / insert size ratio 	<ul style="list-style-type: none"> Maximum radial cutting forces Very high impact loading of the cutting edge when cutting in Burr formation during cut out is probable 	
45°	<ul style="list-style-type: none"> Balanced axial and radial cutting force distribution Minimized impact loading of the cutting edge when cutting in Suitable for brittle materials Burrs / breakage do not occur High table feeds possible 	<ul style="list-style-type: none"> When cutting in and out, a larger clearance is needed – can collide with jig Limited cutting depth 	

Cutting edge angle	Advantages	Effects	Force distribution
10°	<ul style="list-style-type: none"> For highest table feeds Suitable for plunge milling Main cutting force, axial Minimal tendency to vibrate 	<ul style="list-style-type: none"> High axial load of the spindle bearings Stable components and device required 	
Round inserts	<ul style="list-style-type: none"> Suitable for many application areas and materials Thin chip formation possible high feeds Amount of cutting force depends on the depth of contact 	<ul style="list-style-type: none"> Moderate load on the spindle 	

**CHIP THICKNESS H
DEPENDING ON THE CUTTING EDGE ANGLE**

Cutting edge angle	Chip thickness h
90°	$h = f_t$
75°	$h = 0.96 \cdot f_t$
45°	$h = 0.707 \cdot f_t$
10°	$h = 0.17 \cdot f_t$
Round inserts	$= (iC^2 \cdot (iC - 2a_p)^2 \cdot f_t)^{-1/2}$

The calculation of the chip thickness h applies to contact conditions in which the milling cutter is centered in contact.

As the cutting edge angle decreases, the chip thickness h also decreases. A smaller chip thickness h means that a higher feed speed can be driven and thus productivity increased.

In general, the chip thickness h can be calculated using the formula $h = \sin K_r \cdot f_t$.

CALCULATION OF MACHINE OUTPUT

In order to determine the required spindle power, the stock-removal rate (Q) must first be calculated. The stock-removal rate is also a measure of the machining efficiency. The unit of measure is mm³/min. The higher the stock-removal rate, the faster a workpiece can be machined.

Stock-removal rate Q

Depending on the chip cross section, the stock-removal rate can be calculated as follows: $Q = h \cdot v_f$ (mm² · mm/min)

In general, however, the stock-removal rate can also be calculated by the contact width a_e : $Q = a_p \cdot a_e \cdot v_f$ (mm³/min)

Calculation of the drive power P_c

For a simplified calculation of the required drive power, the output quantity is the stock-removal rate Q:

$$Q = a_p \cdot a_e \cdot v_f \text{ (mm}^3\text{/min)}$$

The following applies to the cutting power P_c : $P_c = \frac{Q}{K}$ with K = specific chip volume (depending on the material).

The following then applies to the drive power:

$$P_c = \frac{a_p \cdot a_e \cdot v_f \cdot k_c}{60 \cdot 10^3} \text{ [W]}, \text{ or } P_c = \frac{a_p \cdot a_e \cdot v_f \cdot k_c}{60 \cdot 10^6} \text{ [kW]}$$

The specific material-dependent cutting force k_c is shown in the following table for some common cast iron materials:

GJL and GJS	k_c factor [N/mm ²]
GJL 150	1,500
GJL 200	1,800
GJL 250	2,100
GJS 400	1,800
GJS 500	1,850
GJS 600	3,100
GJS 700	3,200
Approximations for $h = 0.10$ mm	

k_c also results from the relationship $K = \frac{1}{k_c}$

This results in the required drive power P_m at an efficiency of η ($\eta = 0.75 - 0.90$) with $P_m = \text{[kW]} \frac{P_c}{\eta}$



SURFACE QUALITY FOR MILLING

The surface quality produced during the milling of a workpiece is a central production and quality measure. When milling with ceramic, PcBN, and cermets, surface qualities with a roughness value of $R_a \leq 0.5 \mu\text{m}$ can be reliably achieved. In addition to roughness, waviness and flatness are important surface values.

The values that can be achieved depend on many factors:

Stiffness of the machine, spindle situation, clamping situation, machinability of the material, cutting speed and cutting depth, milling cutter design, cutting edge design, wear behavior / state of wear of the insert.

One of the most important options for influencing the surface qualities results from the preparation of the cutting edge. The following table shows the options.

Cutting edge design		
	small corner radius	<ul style="list-style-type: none"> · Distinct feed marks · For roughing surfaces
	larger corner radius	<ul style="list-style-type: none"> · Moderate feed markings · Generates roughing surfaces
	with the face cutting edge	<ul style="list-style-type: none"> · Face cutting edges and wiper (ZZ) designs of inserts generate minimum feed markings · Depending on the cutting edge design, surface qualities of Ra less than 0.5 can be generated
	Round inserts	<ul style="list-style-type: none"> · Round inserts produce a uniform corrugation profile. Due to their mode of contact, surfaces can be produced in roughing finishing quality

The figures make it clear what effect the cutting edge design has on the surface quality. Further options to produce better surface qualities result from: Increase in the cutting speed with simultaneous withdrawal of the feed. However, this can lead to problems with heat dissipation. The heat input into the workpiece is higher and the heat load of the insert also increases.

The axial run-out of the milling cutter also has a significant influence on the surface quality. An exact axial run-out produces significantly better surface qualities.

Fine-finish surfaces are best produced using wiper-style inserts and milling cutters with insert seats adjustable in the Z direction. The adjustable insert seats are equipped with ZZ-inserts and raised in the Z direction by 0.025 to 0.1 mm.

Formulas

CALCULATION FORMULAS

MILLING FORMULAS

Cutting speed (m/min)	$v_c = \frac{\pi \cdot D_c \cdot n}{1000}$
Spindle speed (rpm):	$n = \frac{v_c \cdot 1000}{\pi \cdot D_c}$
Feed rate (mm/min):	$v_f = f_t \cdot n \cdot z_n$
Feed per tooth (mm):	$f_t = \frac{v_f}{n \cdot z_n}$
Feed per revolution (mm):	$f_n = \frac{v_f}{n}$
Stock-removal rate (cm ³ /min):	$Q = \frac{a_p \cdot a_e \cdot v_f}{1000}$
Average chip thickness (mm) (Peripheral and face milling) if $a_e / D_c \leq 0.1$:	$h_m = f_t \sqrt{\frac{a_e}{D_c}}$
Average chip thickness (mm) if $a_e / D_c > 0.1$:	$h_m = \frac{\sin K_f \cdot 180 \cdot a_e \cdot f_t}{\pi \cdot D_c \cdot \arcsin \frac{a_e}{D_c}}$
Contact time (min):	$T_c = \frac{l_m}{v_f}$
Drive power (kW):	$P_c = \frac{a_p \cdot a_e \cdot v_f \cdot k_c}{60 \cdot 10^6 \cdot \eta}$

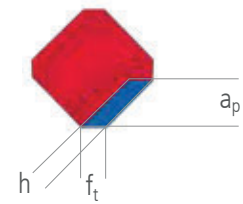
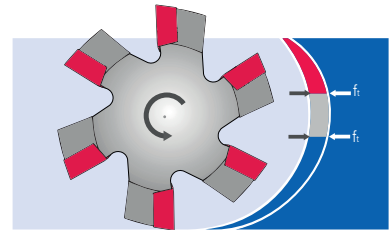

FORMULA FOR FACE MILLING WITH STRAIGHT CUTTING EDGES

Max. diameter at given cutting depth (mm):

$$D_c = D + \frac{2 \cdot a_p}{\tan \varphi}$$

Centered milling, feed per tooth (mm/teeth):

$$f_t = \frac{h}{\sin \varphi}$$

FORMULA FOR FACE MILLING WITH HIGH-FEED MILLING CUTTERS

Calculation of tooth feed taking the h_m -value into account for contact angle $< 90^\circ$

x° = degree of adjustment angle, f_t = tooth feed, h_m = center chip thickness

f_t according to program = 0.15 mm/Z (nominal), $x^\circ = 15^\circ$

$h_m = f_t \cdot \sin x^\circ$ ($h_m = 0.15 \times 0.25882 = 0.0388$ mm)

At a cutting edge angle of 15° , a programmed tooth feed f_t of 0.15 will only yield an actual chip thickness of just 0.04 mm!

Objective: Chip thickness $h_m = 0.15$ mm

Necessary correction for f_t :

$f_t = h_m / \sin x^\circ$ ($f_t = 0.15 / 0.25882 = 0.57955$ mm)

For f_t of 0.588 mm = actual chip thickness of 0.15 mm

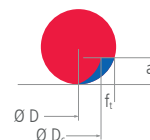
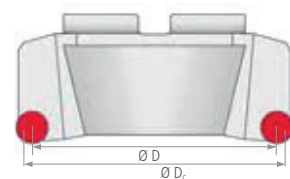
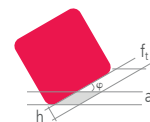

FACE MILLING WITH ROUND INSERTS

Max. diameter at given cutting depth (mm):

$$D_c = D + \sqrt{iC^2 - (iC - 2a_p)^2}$$

Central milling

Feed per tooth (mm/tooth):

for $a_e > \frac{D_c}{2}$

$$f_t = \frac{iC \cdot h}{2 \cdot \sqrt{a_p \cdot iC - a_p^2}}$$

Helical milling

1. SELECTION OF MILLING CUTTER DIAMETER DEPENDING ON THE BORE SIZE

The key factor in helical milling is the correct ratio of milling cutter diameter to bore diameter. It is important to ensure that the insert cuts along its central axis.

If too small a milling cutter diameter is chosen, a core remains in the center.

If the milling cutter diameter is too large, the center remains unprocessed and a pin is created. This forms more and more and comes to a collision between the workpiece and the tool.

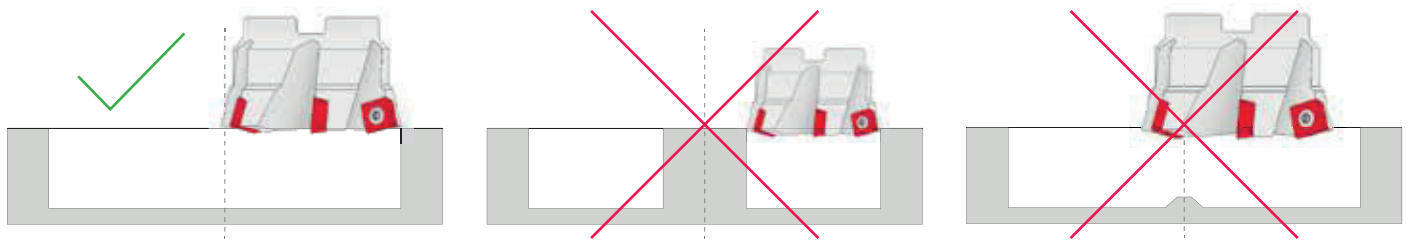

2. PITCH

The pitch P depends on the bore diameter, milling cutter diameter and plunge angle. It can never be greater than the maximum a_p of the respective milling cutter.

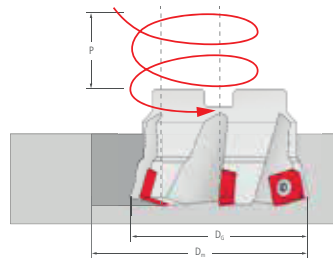

3. FEED RATE

The feed value is always dependent on the h_m value, which corresponds to the peripheral feed rate v_{fm} .

Frequently, machines require a tool center feed v_f , which must be calculated accordingly:

$$f_t = h_m$$

$$v_{fm} = n \cdot f_t \cdot z_c$$

$$v_f = \frac{D_{vf}}{D_m} \cdot v_{fm}$$

D_{vf} = programmed milling path (circular path of milling cutter)
 D_m = outer diameter (milled)

Programmed feed rate:

v_{fm} = (with radius compensation)

Feed rate - tool periphery

v_f = (with radius compensation)

Feed rate - tool center axis

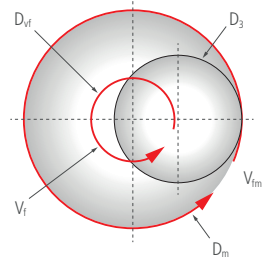

4. HELICAL MILLING IN SOLID MATERIAL / ENLARGE BORE

a) Helical milling in solid material

Milling cutter diameter (mm)	63	80	100
Drilling diameter (mm)	113 – 126	147 – 160	187 – 200

Note: With a drilling diameter between two specified ranges, for example 130 mm, the smaller milling cutter with a diameter of 63 mm is selected. Two processing steps are then necessary.

b) enlarging bore (no face machining)

– milling cutter diameter = $\leq 0.5 \times$ drilling diameter

OVERVIEW OF R_t , R_a , R_z , W AND W_t

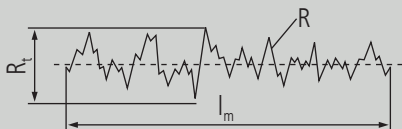

Maximum roughness depth R_t

is the vertical distance between the highest and the lowest point of the roughness profile R within the total measuring section l_m .

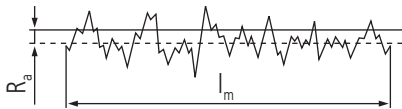

Average roughness value R_a

is the arithmetic mean of the absolute values of all distances of the roughness profile R from the central line within the total measuring section l_m .

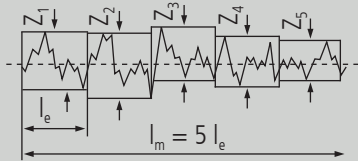

Average roughness depth R_z

is the mean of the single depths of roughness of five successive individual measuring sections l_e .

$$R_z = (Z_1 + Z_2 + Z_3 + Z_4 + Z_5)$$

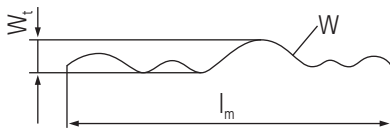







Corrugation profile W

is the middle line through the traced profile P.

Maximum corrugation depth W_t is the vertical distance between the highest and lowest points of the corrugation profile W within the total section l_m .

Surface signs

Meaning as per DIN 3141	Assignment of the maximum permissible roughness depth R_t to the mean roughness value R_a					Meaning
		1	2	3	4	
	arbitrary					Surfaces for which no specific requirements are made.
	arbitrary					Surfaces for which higher requirements are placed on greater uniformity and better appearance.
	Rt	160	100	63	25	Surfaces with a roughness that may not exceed the upper limit of the mean roughness value.
	Ra	25	12.5	6.3	3.2	
	Rt	40	25	16	10	
	Ra	6.3	3.2	1.6	0.8	
	Rt	16	6.3	4	2.5	
	Ra	1.6	0.8	0.4	0.2	
	Rt		1	1	0.4	
	Ra		0.1	0.1	0.025	

a = average roughness value R_a in μm

Comparison $R_a - R_t$

Determination of the roughness depth R_t for the prescribed average roughness value R_a or determination of the average roughness value R_a for the prescribed depth of roughness R_t , taking the scatter range and adequate safety into account.

The dark-rastered field lying within the scattering range (broad band) bounded by the two straight lines, includes at least 70% of the roughness pairs R_t and R_a of all areas produced by machining. If the upper line within the scatter range is used to determine the upper limit of the R_t value for the prescribed R_a value, it can be safely assumed that at least 85% of all cases of application will not exceed the prescribed R_a value. The same applies to the R_t value.

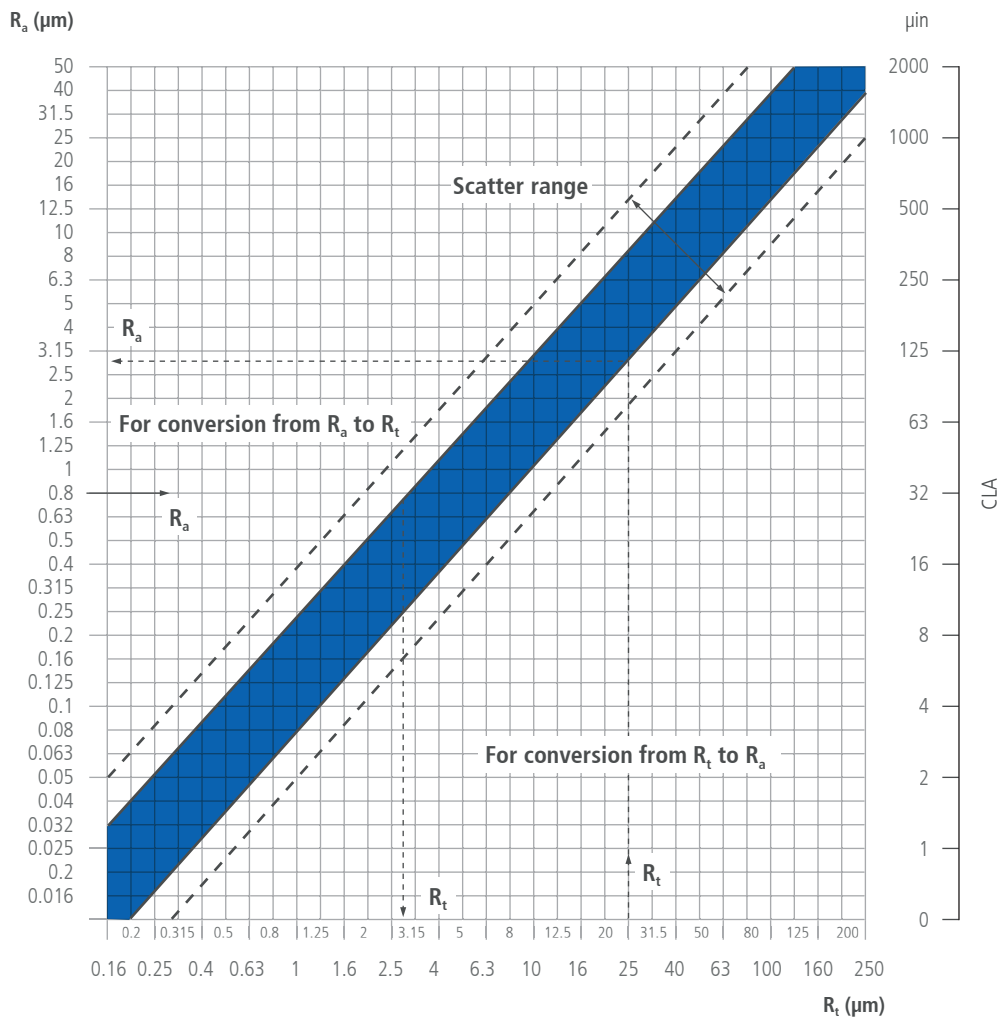

Comparison values $R_a - R_t$

COMPARISON VALUES FOR R_a

R_a (μm)	CLA (μin)	RMS (μin)	R_t (μm)
0.02	0.8	0.9 – 1.0	0.1 – 0.3
0.04	1.6	1.8 – 1.9	0.2 – 0.5
0.06	2.4	2.8 – 2.9	0.3 – 0.7
0.08	3.2	3.5 – 3.8	0.4 – 0.8
0.10	4.0	4.4 – 4.8	0.5 – 1.0
0.12	4.8	5.3 – 5.8	0.6 – 1.2
0.14	5.6	6.2 – 6.7	0.7 – 1.6
0.16	6.4	7.0 – 7.7	0.7 – 1.6
0.18	7.2	7.9 – 8.6	0.8 – 1.7
0.20	8.0	8.8 – 9.6	0.9 – 1.9
0.25	10.0	11.0 – 12.0	1.1 – 2.3
0.30	12.0	13.2 – 14.4	1.3 – 2.7
0.35	14.0	15.4 – 16.8	1.5 – 3.0
0.40	16.0	17.6 – 19.2	1.7 – 3.4
0.45	18.0	19.8 – 21.6	1.9 – 3.8
0.65	26.0	28.6 – 31.2	2.7 – 5.2
0.9	36.0	39.6 – 43.2	3.7 – 7.0
1.1	44.0	48.4 – 52.8	4.5 – 8.2
1.3	52.0	57 – 62	5.2 – 9.5
1.5	60.0	66 – 72	6.0 – 10.5
1.8	72.0	79 – 86	7.1 – 12.5
2.5	100.0	110 – 120	9.6 – 16.5
3.5	140.0	154 – 168	13 – 22
4.5	180.0	198 – 216	17 – 28
5.0	200.0	220 – 240	18 – 30
6.0	240.0	264 – 288	22 – 35
7.0	280.0	308 – 336	25 – 40
8.0	320.0	352 – 384	28 – 45
9.0	360.0	396 – 432	32 – 50
10.0	400.0	440 – 480	35 – 56
11.0	440.0	484 – 528	38 – 60
13.0	520.0	572 – 624	45 – 70
15.0	600.0	660 – 720	51 – 78

COMPARISON VALUES FOR R_t

R_t (μm)	R_a (μm)	CLA (μin)	RMS (μin)
0.01	0.007 – 0.02	0.3 – 0.8	0.3 – 1.0
0.02	0.016 – 0.04	0.6 – 1.6	0.7 – 1.9
0.03	0.025 – 0.06	1.0 – 2.4	1.1 – 2.9
0.04	0.035 – 0.08	1.4 – 3.2	1.5 – 3.8
0.5	0.045 – 0.11	1.8 – 4.4	2.0 – 5.3
0.6	0.055 – 0.13	2.2 – 5.2	2.4 – 6.2
0.7	0.065 – 0.15	2.6 – 6.0	2.9 – 7.2
0.8	0.075 – 0.18	3.0 – 7.2	3.3 – 8.6
0.9	0.085 – 0.20	3.4 – 8.0	3.8 – 9.6
1.0	0.10 – 0.22	4.0 – 8.8	4.3 – 10.6
1.2	0.12 – 0.27	4.8 – 10.8	5.3 – 12.9
1.4	0.15 – 0.32	6.0 – 12.8	8.4 – 15.4
1.6	0.17 – 0.37	6.8 – 14.8	7.5 – 17.8
1.8	0.19 – 0.42	7.6 – 16.8	8.5 – 20.2
2.0	0.22 – 0.47	8.8 – 18.8	9.7 – 22.6
2.5	0.28 – 0.59	11.4 – 25.2	12.4 – 28.3
3.0	0.35 – 0.72	14.0 – 28.8	15.4 – 34.5
4.0	0.48 – 0.98	19.2 – 39.2	21.1 – 47.0
5.0	0.62 – 1.25	24.8 – 50.0	27.3 – 60.0
6.0	0.76 – 1.50	30.4 – 60.0	33.4 – 72.0
7.0	0.90 – 1.77	36.0 – 71.0	39.6 – 85.2
8.0	1.06 – 2.05	42.5 – 82.0	46.8 – 98.4
9.0	1.2 – 2.3	48.0 – 92.0	52.8 – 110
10.0	1.4 – 2.6	55 – 104	62 – 125
12.0	1.7 – 3.2	68 – 128	75 – 154
14.0	2.0 – 3.8	80 – 152	88 – 182
16.0	2.4 – 4.3	96 – 172	106 – 206
18.0	2.7 – 4.9	108 – 196	119 – 235
20.0	3.1 – 5.5	124 – 220	136 – 264
25.0	4.0 – 7.0	160 – 280	176 – 336
30.0	5.0 – 8.5	200 – 340	220 – 406
40.0	7.0 – 11.5	280 – 460	308 – 552
50.0	9.0 – 15.0	360 – 600	396 – 720

A precise mathematical comparison of R_t , R_a , CLA and RMS is not possible. The values given in the table are therefore comparative values, which were determined empirically.

CONVERSION TABLES FROM METRIC TO INCHES

DIAMETER		DIAMETER		CUTTING DEPTH		CUTTING SPEED	
mm	Inch	mm	Inch	mm	Inch	m/min.	sfm
8.0	.314	76.2	3,000	0.254	.010	91	300
9.5	.375	80.0	3,149	0.381	.015	122	400
10.0	.393	88.9	3,500	0.762	.030	152	500
12.0	.472	100.0	3,937	1.270	.050	183	600
12.7	.500	101.6	4,000	2.540	.100	244	800
15.9	.625	125.0	4,921	3.175	.125	305	1000
16.0	.630	127.0	5,000	3.810	.150	366	1200
19.1	.750	152.4	6,000	6.350	.250	610	2000
20.0	.787	160.0	6,299	9.525	.375	1219	4000
22.2	.875	177.8	7,000	12.700	.500	3048	10000
25.0	.984	200.0	7,874				
25.4	1,000	203.2	8,000				
32.0	1,259	250.0	9,842				
38.1	1,500	254.0	10,000				
50.0	1,968	304.8	12,000				
50.8	2,000	315.0	12,401				
63.0	2,480	355.6	14,000				
63.5	2,500	400.0	15,748				
FEED C.P.T.		SURFACE QUALITY (RA)					
mm/T	Inch/T	μm	μ Inch				
0.076	.003	12.5	500				
0.12	.004	6.3	250				
0.127	.005	3.2	125				
0.152	.006	1.6	63				
0.178	.007	0.8	32				
0.203	.008	0.4	16				
0.229	.009						
0.254	.010						
0.279	.011						
0.305	.012						

Ratio of Brinell hardness to Rockwell

RATIO OF BRINELL HARDNESS HB TO ROCKWELL HRC

Rockwell C hardness number (HRC)		Conversion Rockwell C hardness (HRC) in Brinell hardness (HB)
from	to	
21	30	$HB = 5.970 \times HRC + 104.7$
31	40	$HB = 8.570 \times HRC + 27.6$
41	50	$HB = 11.158 \times HRC + 79.6$
51	60	$HB = 17.515 \times HRC - 401$

RATIO OF BRINELL HARDNESS HB TO ROCKWELL HRB

Rockwell B hardness number (HRB)		Conversion Rockwell B hardness (HRB) in Brinell hardness (HB)
from	to	
55	69	$HB = 1.646 \times HRB + 8.7$
70	79	$HB = 2.394 \times HRB - 42.7$
80	89	$HB = 3.297 \times HRB - 114$
90	100	$HB = 5.582 \times HRB - 319$

HARDNESS		
Brinell	Rockwell	
HB	HRB	HRC
654*	–	60
634*	–	59
615	–	58
595	–	57
577	–	56
560	–	55
543	–	54
525	–	53
512	–	52
496	–	51
481	–	50
469	–	49
455	–	48
443	–	47
432	–	46
421	–	45
409	–	44
400	–	43
390	–	42
381	–	41
371	–	40
362	–	39
353	–	38
344	–	37
336	109.0*	36

HARDNESS		
Brinell	Rockwell	
HB	HRB	HRC
327	108.5*	35
319	108.0*	34
311	107.5*	33
301	107.0*	32
294	106.0*	31
286	105.5*	30
279	104.5*	29
271	104.0*	28
264	103.0*	27
258	102.5*	26
253	101.5	25
247	101.0	24
243	100.0	23
237	99.0	22
231	98.5	21
228	98.0	20
222	97.0	18.6*
216	96.0	17.2*
210	95.0	15.7*
205	94.0	14.3*
200	93.0	13*
195	92.0	11.7*
190	91.0	10.4*
185	90.0	9.2*
180	89.0	8*

HARDNESS		
Brinell	Rockwell	
HB	HRB	HRC
176	88.0	6.9*
172	87.0	5.8*
169	86.0	4.7*
165	85.0	3.6*
162	84.0	2.5*
159	83.0	1.4*
156	82.0	0.3*
153	81.0	–
150	80.0	–
147	79.0	–
144	78.0	–
141	77.0	–
139	76.0	–
137	75.0	–
135	74.0	–
132	73.0	–
130	72.0	–
127	71.0	–
125	70.0	–
123	69.0	–

* The marked values are outside the standard range.

Formula symbols



a_e	mm	Angle of action width
a_e/D		Coverage ratio
a_p	mm	Cutting depth
b	mm	Cutting width
b_γ	mm	Chamfer width
D	mm	Milling cutter diameter
D_c	mm	Effective diameter
D_m	mm	Outer diameter (workpiece)
D_{vf}	mm	Circular path diameter
F_c	N	Cutting force
f_t	mm	Feed / tooth
h	mm	Chip thickness
h_m	mm	Average chip thickness
k_c	N/mm ²	Specific cutting force
$k_{c1.1}$	N/mm ²	Specific cutting force (based on the chip cross-section $b \cdot h = 1 \cdot 1\text{mm}^2$)
l	mm	Cutting edge length
l_c	m	Cutting path
l_e	mm	Individual measurement length
l_f	m	Milling path
l_{fz}	m	Milling path / tooth
l_m	mm	Overall measurement section
n	rpm	Rotational speed
P_c	kW	Spindle power
P_{mot}	kW	Motor output
R	μm	Roughness profile
R_a	μm	Arithm. average roughness value
R_m	N/mm ²	Tensile strength
R_t	μm	Maximum roughness depth
R_z	μm	Average roughness depth
r_e	mm	Cutting corner radius
s	mm	Insert thickness
T	min	Tool life
VB	mm	Wear land width
v_c	m/min	Cutting speed
v_f	mm/min	Feed rate
v_{fm}	mm/min	Peripheral feed rate

t		Teeth number
Z_t	μm	Single depth of roughness
η		Efficiency of the machine tool
α_n	Degree	Clearance angle
β_n	Degree	Wedge angle
γ_a	Degree	Axial rake angle
γ_n	Degree	Rake angle
γ_r	Degree	Radial rake angle
γ_s	Degree	Chamfer angle
χ_r	Degree	Cutting edge angle
λ_s	Degree	Tilt angle
φ	Degree	Pressure angle
φ_A	Degree	Exit angle
φ_E	Degree	Entrance angle

Material comparison tables

Country									
Europe	Germany	UK		Sweden	USA	France	Italy	Spain	Japan
Standard									
DIN EN	W.-no.	BS	EN	SS	AISI/SAE/ASTM	AFNOR	UNI	UNE	JIS

Malleable cast iron

-	-	8 290/6	-	0814	-	MN 32-8	-	-	FCMB310
EN-GJMB350-10	0.8135	B 340/12	-	0815	32510	MN 35-10	-	-	FCMW330
EN-GJMB450-6	0.8145	P 440/7	-	0852	40010	Mn 450	GMN 45	-	FCMW370
EN-GJMB550-4	0.8155	P 510/4	-	0854	50005	MP 50-5	GMN 55	-	FCMP490
		P 570/3		0858	70003	MP 60-3			FCMP540
EN-GJMB650	0.8165	P 570/3	-	0856	A220-70003	Mn 650-3	GMN 65	-	FCMP590
EN-GJMB700-2	0.8170	P 690/2	-	0862	A220-80002	Mn 700-2	GMN 70	-	FCMP690

Gray iron

-	-	-	-	0100	-	-	-	-	-
EN-GJL-100	0.6010	-	-	0110	No 20 B	Ft 10 D	-	-	FC100
EN-GJL-150	0.6015	Grade 150	-	0115	No 25 B	Ft 15 D	G 15	FG 15	FC150
EN-GJL-200	0.6020	Grade 220	-	0120	No 30 B	Ft 20 D	G 20	-	FC200
EN-GJL-250	0.6025	Grade 260	-	0125	No 35 B	Ft 25 D	G 25	FG 25	FC250
EN-JLZ	0.6040	Grade 400	-	0140	No 55 B	Ft 40 D	-	-	-
EN-GJL-300	0.6030	Grade 300	-	0130	No 45 B	Ft 30 D	G 30	FG 30	FC300
EN-GJL-350	0.6035	Grade 350	-	0135	No 50 B	Ft 35 D	G 35	FG 35	FC350
GGL-NiCr20-2	0.6660	L-NiCuCr202	-	0523	A436 Type 2	L-NC 202	-	-	-

Spherical graphite cast iron

EN-GJS-400-15	0.7040	SNG 420/12	-	0717-02	60-40-18	FCS 400-12	GS 370-17	FGE 38-17	FCD400
EN-GJS-400-18-LT	0.7043	SNG 370/17	-	0717-12	-	FGS 370-17	-	-	-
EN-GJS-350-22-LT	0.7033	-	-	0717-15	-	-	-	-	-
EN-GJS-800-7	0.7050	SNG 500/7	-	0727	80-55-06	FGS 500-7	GS 500	FGE 50-7	FCD500
EN-GJS-600-3	0.7060	SNG 600/3	-	0732-03	-	FGS 600-3	-	-	FCD600
EN-GJS-700-2	0.7070	SNG 700/2	-	0737-01	100-70-03	FGS 700-2	GS 700-2	FGS 70-2	FCD700
EN-GJSA-XNiCr20-2	0.7660	Grade S6	-	0776	A43D2	S-NC 202	-	-	-

Vermicular graphite cast iron

EN-GJV-300									
EN-GJV-350									
EN-GJV-400									
EN-GJV-450									
EN-GJV-500									

Austenitic-bainitic cast iron

EN-GJS-800-8	-	-	-	-	ASTM A897 No. 1	-	-	-	-
EN-GJS-1000-5	-	-	-	-	ASTM A897 No. 2	-	-	-	-
EN-GJS-1200-2	-	-	-	-	ASTM A897 No. 3	-	-	-	-
EN-GJS-1400-1	-	-	-	-	ASTM A897 No. 4	-	-	-	-
-	-	-	-	-	ASTM A897 No. 5	-	-	-	-

Connection dimensions as per DIN 8030



Holding fixture shape A

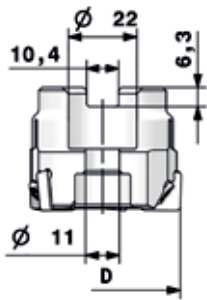

D = 50 mm - 63 mm

Holding fixture shape A

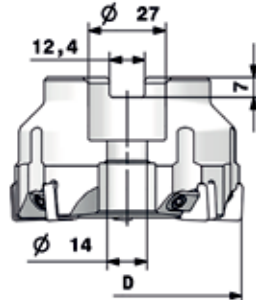

D = 80 mm

Holding fixture shape B

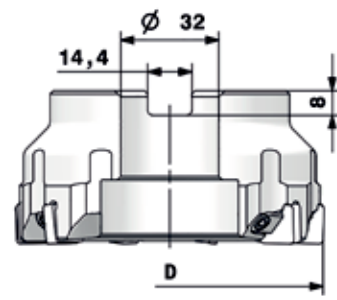

D = 100 mm

Holding fixture shape B

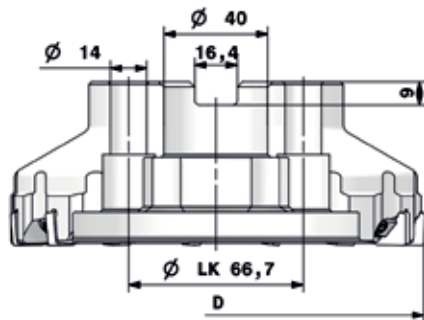

D = 125 mm

Holding fixture shape C

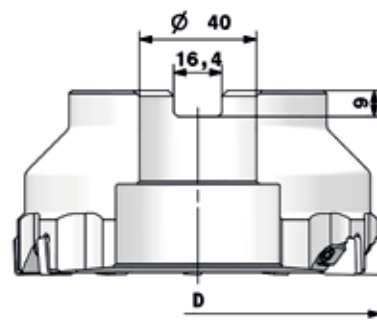

D = 160 mm

Holding fixture shape C

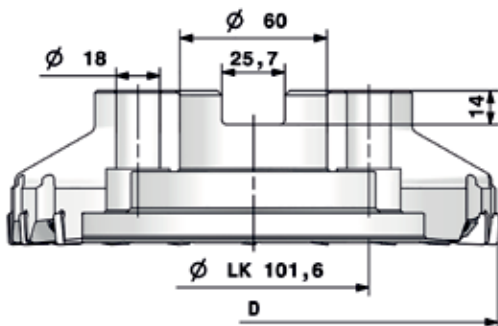

D = 200 - 250 mm

www shape C

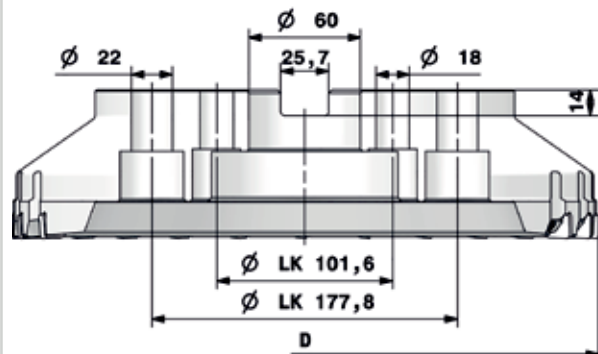

D = 315 mm

Connection dimensions for screw-on milling cutters

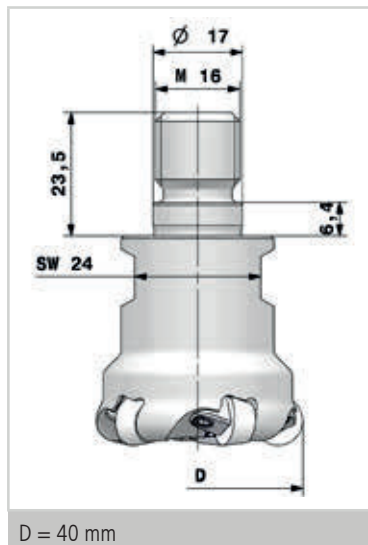
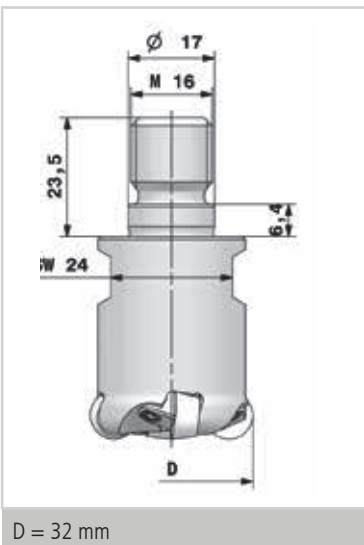
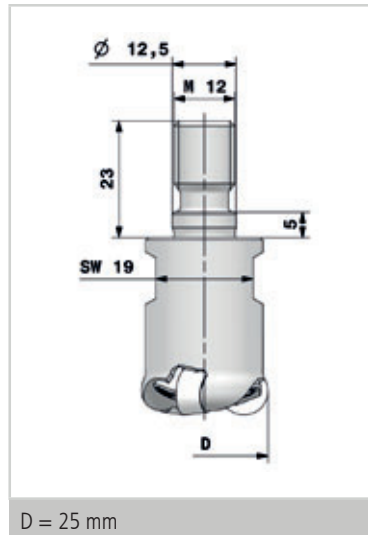
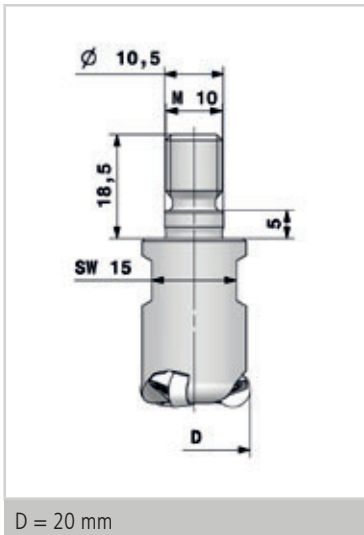

Problem	Problem point	Measure										
		switch to a harder grade	switch to a tougher grade	Cutting speed Vc	Feed per tooth ft	Cutting depth ap	Check cut width ae	Wiper ZZ	Clearance angle	Corner radius	Chamfer	Check workpiece clamping
Rising flank wear *	Unsuitable cutting data			↓	↑							
	Unsuitable tool geometry / WSP **	✓							↑			
Wear on the rake face	Unsuitable cutting data			↓	↓	↓						
	Unsuitable tool geometry / WSP **	✓							↓			
Edge break on the cutting edge	Unsuitable cutting data			↓	↓	↓						
	Unsuitable tool geometry / WSP **		✓							↑	↑	
Bad surface	Unsuitable cutting data				↑			✓				✓
	Unsuitable tool geometry / WSP **							✓				✓
Burr formation	Unsuitable cutting data				↓	↓	↓					
	Unsuitable tool geometry / WSP **								↑	↓	↓	
Edge breaks Workpiece	Unsuitable cutting data				↓	↓	✓					
	Unsuitable tool geometry / WSP **								↑		↓	
Bad flatness / parallelism	Unsuitable cutting data				↓	↓	↓					✓
	Unsuitable tool geometry / WSP **							✓		↓	↓	✓
Heavy rattling / vibrations	Unsuitable cutting data			↓	↑		✓					✓
	Unsuitable tool geometry / WSP **									↓		✓

* Use C2 geometry

** WSP = indexable insert

По вопросам продаж и поддержки обращайтесь:

Алматы (727)345-47-04
Ангарск (3955)60-70-56
Архангельск (8182)63-90-72
Астрахань (8512)99-46-04
Барнаул (3852)73-04-60
Белгород (4722)40-23-64
Благовещенск (4162)22-76-07
Брянск (4832)59-03-52
Владивосток (423)249-28-31
Владикавказ (8672)28-90-48
Владимир (4922)49-43-18
Волгоград (844)278-03-48
Вологда (8172)26-41-59
Воронеж (473)204-51-73
Екатеринбург (343)384-55-89

Иваново (4932)77-34-06
Ижевск (3412)26-03-58
Иркутск (395)279-98-46
Казань (843)206-01-48
Калининград (4012)72-03-81
Калуга (4842)92-23-67
Кемерово (3842)65-04-62
Киров (8332)68-02-04
Коломна (4966)23-41-49
Кострома (4942)77-07-48
Краснодар (861)203-40-90
Красноярск (391)204-63-61
Курск (4712)77-13-04
Курган (3522)50-90-47
Липецк (4742)52-20-81

Магнитогорск (3519)55-03-13
Москва (495)268-04-70
Мурманск (8152)59-64-93
Набережные Челны (8552)20-53-41
Новокузнецк (3843)20-46-81
Ноябрьск (3496)41-32-12
Новосибирск (383)227-86-73
Омск (3812)21-46-40
Орел (4862)44-53-42
Оренбург (3532)37-68-04
Пенза (8412)22-31-16
Петрозаводск (8142)55-98-37
Псков (8112)59-10-37
Пермь (342)205-81-47

Ростов-на-Дону (863)308-18-15
Рязань (4912)46-61-64
Самара (846)206-03-16
Санкт-Петербург (812)309-46-40
Саратов (845)249-38-78
Севастополь (8692)22-31-93
Саранск (8342)22-96-24
Симферополь (3652)67-13-56
Смоленск (4812)29-41-54
Сочи (862)225-72-31
Ставрополь (8652)20-65-13
Сургут (3462)77-98-35
Сыктывкар (8212)25-95-17
Тамбов (4752)50-40-97
Тверь (4822)63-31-35

Тольятти (8482)63-91-07
Томск (3822)98-41-53
Тула (4872)33-79-87
Тюмень (3452)66-21-18
Ульяновск (8422)24-23-59
Улан-Удэ (3012)59-97-51
Уфа (347)229-48-12
Хабаровск (4212)92-98-04
Чебоксары (8352)28-53-07
Челябинск (351)202-03-61
Череповец (8202)49-02-64
Чита (3022)38-34-83
Якутск (4112)23-90-97
Ярославль (4852)69-52-93

Россия +7(495)268-04-70

Казахстан +(727)345-47-04

Беларусь +(375)257-127-884

Узбекистан +998(71)205-18-59

Киргизия +996(312)96-26-47

эл.почта: cgc@nt-rt.ru || сайт: <https://ceramtec.nt-rt.ru>